

**S.A. Ahmed**

Chemistry Dept.,  
College Ibn al Haitham,  
University of Baghdad  
[saad.a.a@ihcoedu.uobaghdad.edu.iq](mailto:saad.a.a@ihcoedu.uobaghdad.edu.iq)

**G.A. Ahmed**

Abo-Gharib Dairy Plant,  
Ministry of Industry,  
Baghdad

**N.H. Kadhum**

Abo-Gharib Dairy Plant,  
Ministry of Industry,  
Baghdad

Received on: 25/05/2016

Accepted on: 19/01/2017

## Neural Network Model predictive control for diary Falling Film Evaporators

**ABSTRACT-** A nonlinear neural network model predictive control (NNMPC) is proposed for an industrial evaporator system. This research is conducted in the Abo-Greeb state enterprise of dairy products. Evaporation process and its prediction model is used in the controller design. In this paper, a nonlinear model of the evaporator system components are described, the presented model of the evaporator system is done with MatLab Simulink 2014b. NNMPC based technique for developing nonlinear dynamic models is carried out from empirical data. Results shows that MPC can be used efficiently in control such systems.

**Keywords:** Evaporator system, Falling Film, Evaporator, Model, NNMPC predictive control, modelling, Process control.

How to cite this article: S.A. Ahmed, G.A. Ahmed and N.H. Kadhum "Neural Network Model predictive control for diary Falling Film Evaporators," *Engineering and Technology Journal*, Vol. 35, Part A, No. 1, pp. 91-96, 2017.

### 1. Introduction

Falling film evaporators are widely used in the foodstuff industry to remove a portion of the water from food. In these evaporators, the temperature difference between heating medium and the liquid is less than 80C [1].

Model Predictive control (MPC) is a model-based control strategy, commercially known "Brainwave", process fluctuations are reduced 50% or more compared with traditional PID controllers using this technique [2]. It is classified under advanced control systems, being popular in the process industries like chemical plants and oil refineries [3]. Controller manufactures like Rocwell Automation, utilized MPC software platform as intelligence layer, which continuously assesses current and predicted data operational data [4].

The advantage of MPC approach is that it is nonlinear model based strategy and the control input limitations are directly carried out [5]. Unlike PID controller, a disadvantage in MPC control is that, the controller is configured to a specific plant, over a period of time, MPC configuration is not valid, result a deterioration in performance [6].

MPC algorithm architecture played with three factors: Prediction horizon ( $N_p$ ), control horizon ( $N_c$ ) and the process model.  $N_p$  is a number of samples in the future the MPC controller predicts the plant output. Control horizon ( $N_c$ ) is a number of samples within the prediction horizon

hence the MPC controller can affect the control action. Process Model includes the information about the controlled process. Process model is used to predict the response according to the manipulated control variables. Then the cost function is minimized to ensure the error is diminished. Different optimization techniques are applied and the output gives the input sequence for the next prediction horizon

### 2. Falling Film Evaporators

Modeling of falling film evaporators (FFE) is studied by many researchers [7,8,9,10,11,12], it depends on many parameters like heat transfer through the caldaria tube wall. Film-wise condensation on the outer side of the tube (i.e. shell side), convective heat transfers through condensate film, conduction through the tube wall and convective heat transfer through the milk film and milk surface evaporation main heat transfers. The basic principle of FFE is shown in Figure 1.

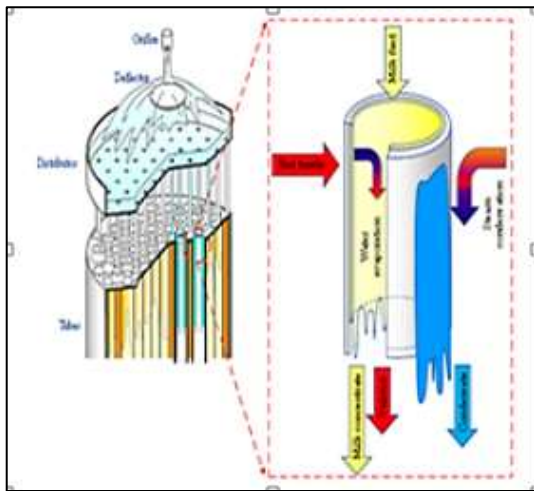

Figure 1: Basic principles of falling film Evaporators [5]

**Research Site**

The research was done in Abo Gareeb dairy state company-Iraq, the flow sequence; process parameters and equipment specification are taken from the plant document. Process parameters are tabulated in Table 1 [13]. Milk from the balance tank is pumped to the Preheater of Calindiria 02 then Preheater of Calindiria 01 with a pump for initial preheating of in-coming milk to 55°C from 5°C by means of Vapor. The Preheated Milk is then go through High Heater to heat the Milk from 55 °C to 75°C, the hot milk enters the three effects falling film evaporation system, vapors are collected and condensed in a barometric condenser used for condensing vapors from all the effects by cooling water.

**3. Modelling**

Modelling is based on the process flow diagram designed by an Indian company Biotech; the plant has three falling film evaporators in cascade manner, with tow preheaters. Each evaporator is integrated with a thermal vapor recompression.

Assumptions

- The overall heat transfer coefficient between milk and steam is constant.
  - The holdup in each effect does not change.
  - Vapor accumulation in effects is neglected.
  - Changes in specific heat of milk are neglected.
- Heat loss from evaporators and preheaters is negligible.

$$\frac{d(M1.x1)}{dt} = F1.x_{f1} - F2.x_{f2} \tag{1}$$

$$\frac{d(M2.x2)}{dt} = F2.x_{f2} - F3.x_{f3} \tag{2}$$

$$\frac{d(M3.x3)}{dt} = F3.x_{f2} - P.x_p \tag{3}$$

$$\frac{d(M1)}{dt} = F1 - F2 - V1 \tag{4}$$

$$\frac{d(M2)}{dt} = F2 - F3 - V2 \tag{5}$$

$$\frac{d(M3)}{dt} = F3 - P - V3 \tag{6}$$

$$\frac{dM_1 H_1}{dx} = M_{i-1} H_{i-1} - M_i H_i - M_{vi} H_{vi} + QI \tag{7}$$

Where F refers to feed stream, F1, is the feed stream to evaporator No.1, V refers to the vapor stream, V1, is the vapor stream leaving the evaporator No. 1, M is the mass hold up in evaporator, H refers to enthalpy, and Q to the heat input.

Jahnamari et al. [12], states the following empirical approximation of the steam mass flowrate, where S is the steam flowrate.

$$Vi = K.MS_{IN} \tag{8}$$

Liquid milk enthalpy:

$$H_l = (4.168 - 3.2 x)T + 5.648 \times 10^{-3}T^2 \tag{9}$$

Vapor enthalpy

$$H_v = 2503.1 + 1.7541 T \tag{10}$$

Condensate enthalpy:

$$H_c = 4.186 T \tag{11}$$

Preheaters

Two preheaters are used to increase the milk temperature to boiling point

$$\frac{dH_f}{dt} = \frac{1}{V_{ppf}} (H_{Fi-1} H_{i-1} - M_F H_{Fi} - M_{vi} H_{vi} - Q_{PHi}) \tag{12}$$

Delays for preheaters are treated as first order process. Supposing a linear relation between heat transfer energy and mass flow of steam. The transfer function from mass flow of steam to mass flow of vapor can be written as:

$$G_{VAP} = e^{-\tau_d s} \frac{K}{\tau s + 1} \tag{13}$$

Where  $\tau_d$  is the delay time and  $\tau$  is the time constant. K is the gain.

$$K = \frac{V}{S_{IN}} \tag{14}$$

Evaporators

A Model for a whole evaporation process of three effects evaporators integrated with thermal vapor recompression (TVR) is stated in the following equations:

Required steam flow:

$$G_{EVAP} = e^{-\tau_d s} \frac{K}{\tau s + 1} \tag{15}$$

The collection tank transfer function:

$$G_T = \frac{1}{\tau_T s + 1} \tag{16}$$

Time constant is measured by applying step input, the time of 63% response is the time constant of the process.

Control Objectives

The main objectives for an evaporation system is to maintain constant product concentration, Fluctuations may be occurred in the feed concentration and steam flow. Environment temperature effect on heat loss, this term is neglected in this work.

Feed concentration

From overall solid content of the milk

$$F \cdot x_f = P \cdot [x]_p \rightarrow [x]_p = (F \cdot x_f) / P$$

The concentration is measured by an online density meter, and the flowrate is measured by orifice meter, the controller is set to the required value of the concentration .In order to achieve this goal, the MPC send a signal to the steam main control valve . Generally, the manipulating steam flowrate to control the disturbance in feed flow, solid concentration of the milk and steam

temperature variables are, the steam flowrate, feed. Regulating milk temperature is very important because it is very sensitive to temperature so as not to cause a spoil to the concentrated milk.

Operating Parameters: [13]

Equipment, Heat Transfer Area for each Calindiria pass (85 m<sup>2</sup>), hold up of each evaporator is (833 kg). Data is taken from the operation and maintenance manual of the plant. The milk from feed balance tank is preheated up to 55 °C in the pre-heaters by the Vapor

**4. Results and discussion**

First of all, building an integral system for analysis, it consists of main five subsystems, one for the preheater and the others for the three effects as shown in Figure 2.some details of subsystems is shown in Figures 3 and 4.

The neural networks model predictive controller (NNMPC) uses a neural network model (NNM) to predict future multi effect falling film responses for Manipulating control signals. An optimization algorithm computes the control signals, which optimize future plant performance. The NNM was trained using the Liebenberg Marquardt algorithm. This algorithm is a least square technique; it is a standard for solving nonlinear problems. Training data were obtained from the nonlinear model of evaporation system. The NNMPC was based on the receding horizon technique. The NNMPC predicts the plant response over a specified time horizon. A numerical optimization program for finding the control signal that minimizes performance criterion over the specified horizon used predictions. Controller block was implemented in Reference [11].

**Table 1: Operating and design parameters of the plant [13]**

	Conc. (kg/kg) milk %	Flow rate (kg/hr)	U <sub>i</sub> W/(m <sup>2</sup> °C)	T °C	τ hr
Feed	5	5,000		6	
1 <sup>st</sup> Effect	8	3125	1735	74	0.167
2 <sup>nd</sup> Effect	11	2273	1290	69	0.267
3 <sup>rd</sup> Effect	14	2,142 L/hr	850	48	3528
Water Evaporation		2,858			0.98
Jacket temperature				74	

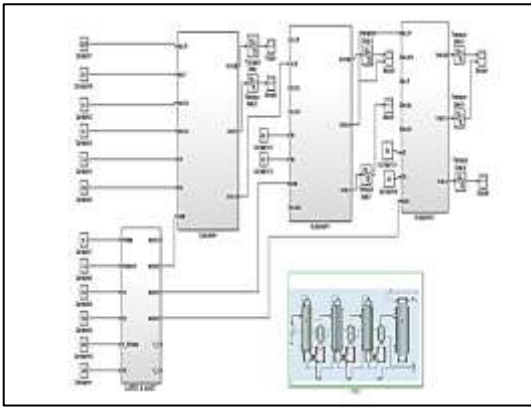

Figure 2: Simulink model subsystem of three falling film evaporator

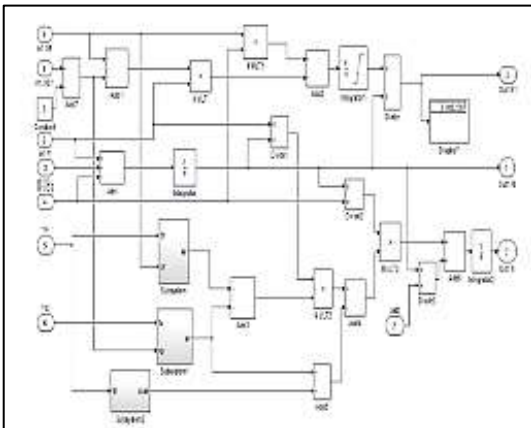

Figure 3: Simulink model subsystem of falling film evaporator

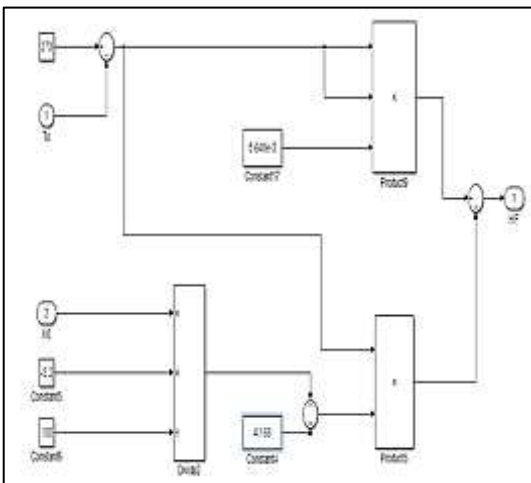

Figure 4: Simulink model subsystem for calculation of liquid enthalpy

As previously mentioned, the evaporators have a same holdup capacity, but different feed input, so they have different time delay values estimated by dividing the holdup on the mass flowrate of the input streams, simulation results for step input open loop test (OLT) and response shown in Figure 5.

The first thing is to create the neural network control system, we chose neural network model predictive controller for this purpose as shown in Figure 6, the controller is configured by entering the parameters which are shown in Figure 7. identification of neural network is shown in Figure 8. Then neural network is trained as in Figure 9. The performance of neural network to 200 epoch is shown in Figure 10. Validation of data is shown in Figure 1, expressed in mean square error, it was found less than  $10^{-4}$ , a regression plot Figure 12, shows good outputs consistency and the targets, Testing data is shown in Figure 13. The response of NN MPC for multi effect evaporators is shown in Figure 14; modeling algorithm succeeds to model this severe nonlinear process with modeling error less than  $10^{-3}$

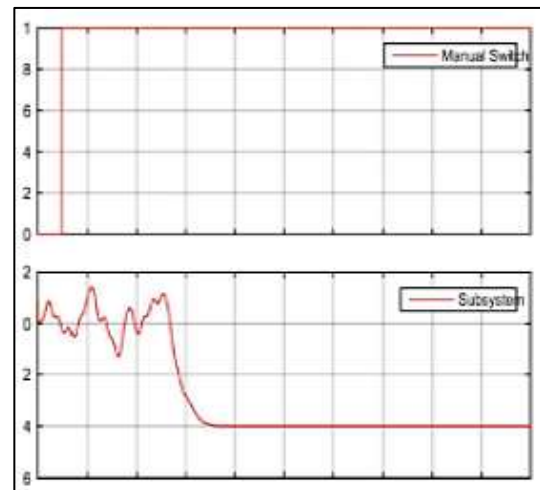

Figure 5: Step input signal OLT

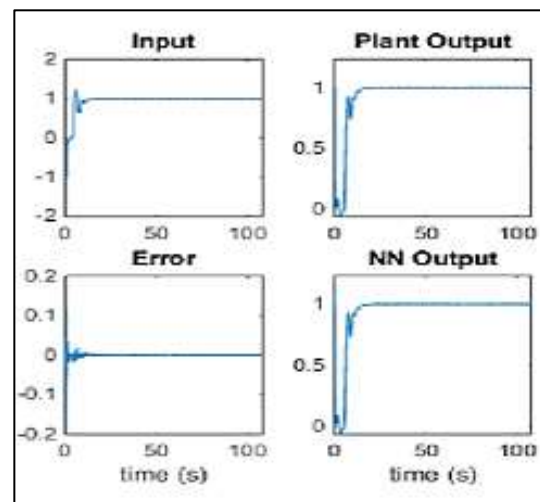

Figure 6: NN MPC system

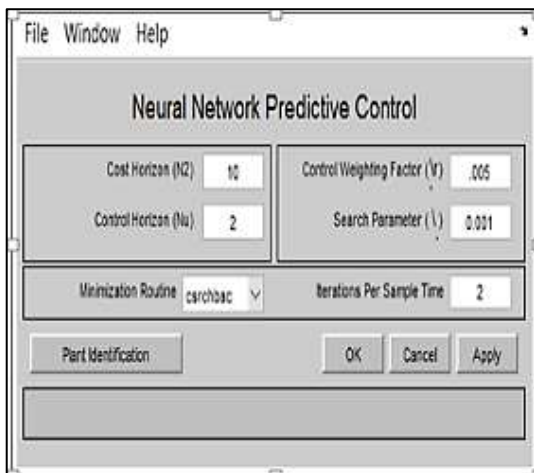

Figure 7: Training neural network

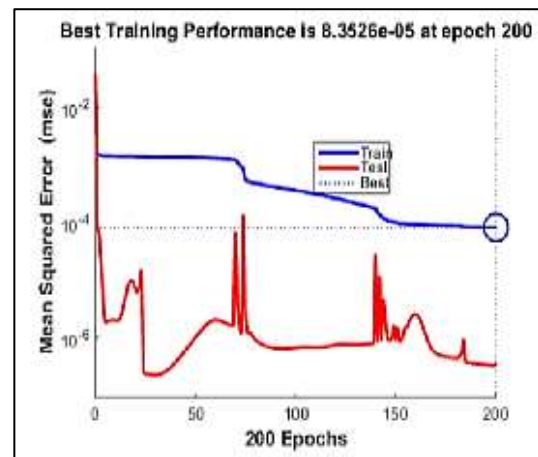

Figure 10: Neural network performance

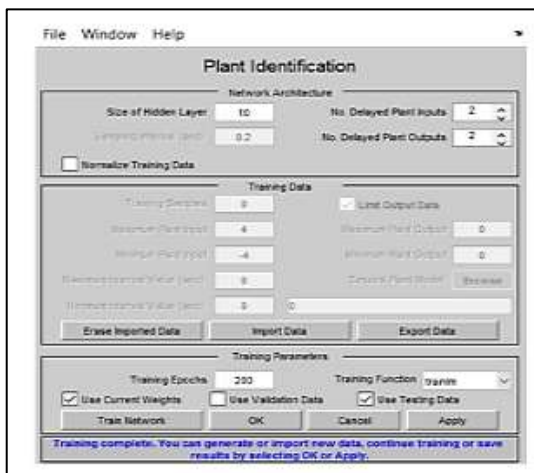

Figure 8: Identification of neural network

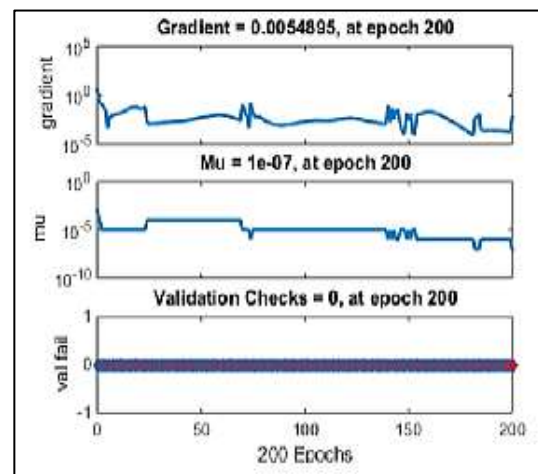

Figure 11: Validation data of NN MPC

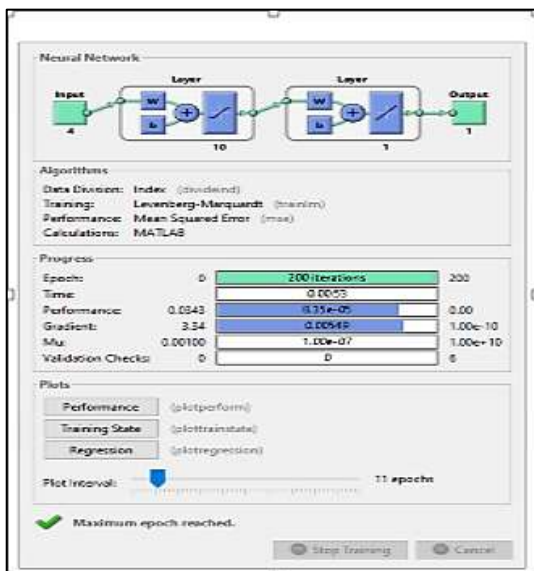

Figure 9: Neural network training

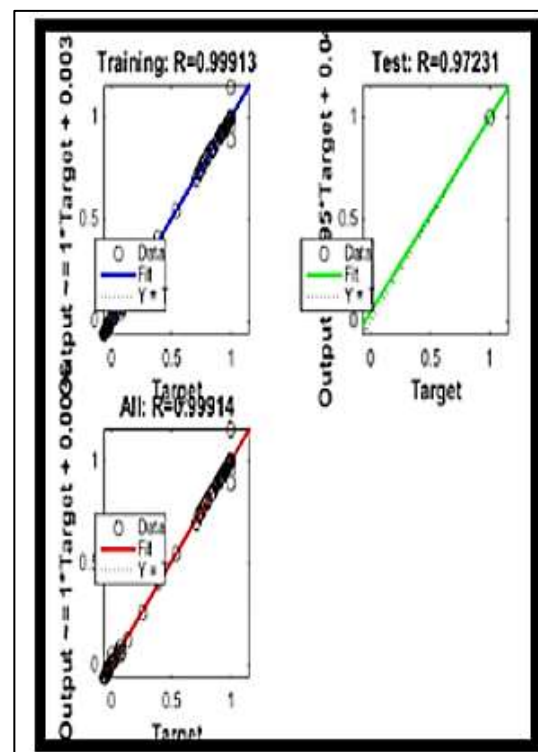

Figure 12: Regression results of NN



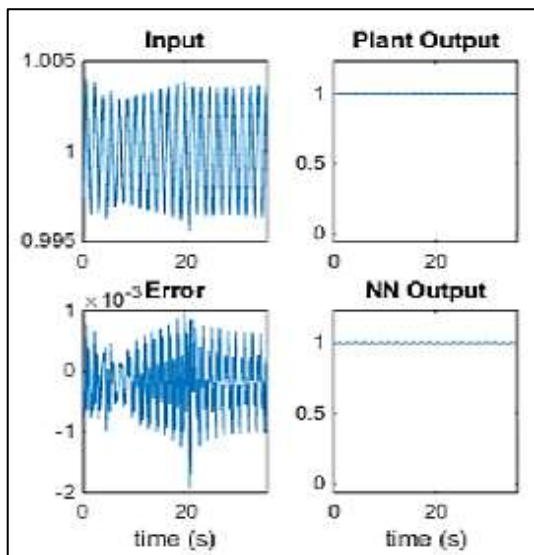

Figure 13: Testing data of NN

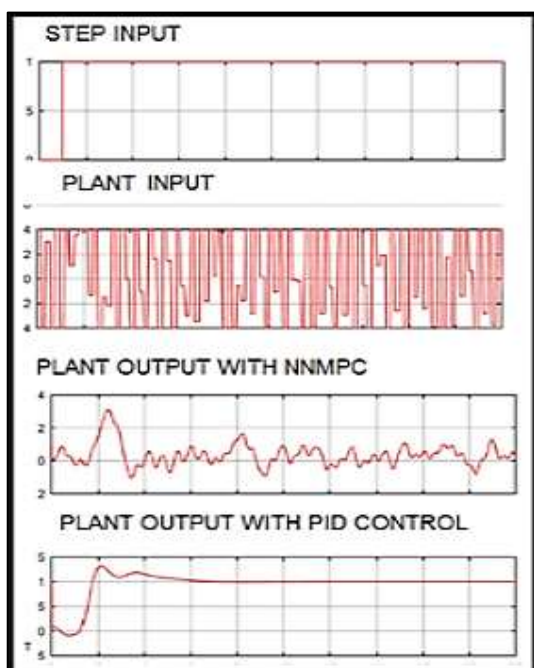

Figure 14: NN MPC controller

## 5. Conclusions

In this paper, an attempt to investigate the NNMPC capability to identify and control triple effect dairy evaporation system. The simulation results confirm that the NNMPC is one of the possibilities for successful control of falling film evaporators. Comparison of the MBPC simulation results with classical PID control demonstrates the effectiveness and superiority of the proposed approach. These properties are apparent, especially in the case, when the controlled process is affected by disturbances.

## References

- [1] I.A. Hassan, A. Sadikin and N. Mat Isa "The Computational Modeling of Falling Film Thickness Flowing Over Evaporator Tubes," *Journal of Advanced Research in Fluid Mechanics and Thermal Sciences*, 14, 1, 24-37, 2015.
- [2] T. Zheng, "Advanced Model Predictive Control Published by InTech, Janeza Trdine 9, 51000 Rijeka, Croatia, 2011.
- [3] S. Ahmed, M. Petrov, A. Taneva, Y. Todorov "Nonlinear Model Predictive Control of an Evaporator System Using Fuzzy-Neural Model," Workshop on Dynamics and Control in Agriculture and Food Processing 13-16 June, Plovdiv, Bulgaria, DYCAF 2012.
- [4] Rockwell Automation, rsbrp8-br001\_-en-p, 2012.
- [5] A. Draeger, S. Engell and H. Ranke "Model Predictive Control Using Neural Networks," IEEE Control Systems, October 1995.
- [6] M. Jimoh "A Vision for MPC Performance Maintenance," Ph.D. Thesis, Glasgow University, Scotland, 2013.
- [7] D. Alberto, J. Luis and D. Sebastián "Modeling of a Falling Film Evaporator," Proceedings of the 9th International Modelica Conference 3-5, Munich Germany, September, 2012.
- [8] N.T. Russel "Dynamic Modelling of Falling Film Evaporators," PhD Thesis, Massey University, 1997.
- [9] M. Karimi and A. Jahanamiri "Nonlinear Modeling and Cascade Control for Multi Effect Falling Film Evaporators," *Iranian Journal of Chemical Engineering*, 3, 2, 53-63, 2006.
- [10] M.S. Elliott and B.P. Rasmussen "A Model-Based Predictive Supervisory Controller for Multi-Evaporator HVAC Systems," American Control Conference, Hyatt Regency Riverfront, St. Louis, MO, USA, June 10-12, 2009.
- [11] H. Hedenberg "Modelling and Control of an Evaporation Process," MSc Thesis, Lund University, 2015.
- [12] M. Farisi and A. Jahanamiri "A New Control Algorithm for Concentration Control in Three Effect Falling Film Evaporators," *Iranian Journal of Science & Technology, Transaction B, Engineering*, 33, B5, 387-396, 2009.
- [13] CDC Unified Process Practical guide, Operation and Maintenance Manual, Milk Evaporation Plant (a property for Abo Gareeb Dairy plant), 2008.