



## Performance evaluation of Photovoltaic Panels by a Proposed Automated System Based on Microcontrollers

Mustafa Q. Ali <sup>a\*</sup>, Monaf S. Tapou <sup>b</sup>, Hayder A. Dhahad <sup>c</sup>

<sup>a</sup> University of Technology, Cont. & sys. Eng. Dep., Baghdad, Iraq. [mustafaquassay@cois.uobaghdad.edu.iq](mailto:mustafaquassay@cois.uobaghdad.edu.iq)

<sup>b</sup> University of Technology, Cont. & sys. Eng. Dep., Baghdad, Iraq. [monaf.tapou@gmail.com](mailto:monaf.tapou@gmail.com)

<sup>c</sup> University of Technology, Mechanical Eng. Dep., Baghdad, Iraq. [10592@uotechnology.edu.iq](mailto:10592@uotechnology.edu.iq)

\*Corresponding author.

Submitted: 08/03/2020

Accepted: 09/04/2020

Published: 25/01/2021

### KEY WORDS

Embedded devices,  
Lab VIEW,  
Microcontroller,  
Phase control,  
Photovoltaic, Pulse  
Width Modulation

### ABSTRACT

*In this paper, an automated test setup for PV panels using LabVIEW and several microcontrollers ( $\mu$ Cs) based embedded systems has been designed, tested, and implemented. This PV testing system has been characterized as fully automated and the only human intervention required is to install the PV panel and to set the required testing conditions. Several PV panels were evaluated and tested, the obtained results showed a high degree of accuracy and conformity with several testing schemes that have been carried out numerically, manually and manufacturer specifications. The designed system is characterized by a high-performance standard with accuracy, precision, and resolution (9 mV / 1.8 mA) that is good enough to test any PV panel of 12 V and 24 V rating. This system can test and calculate the maximum power point for any PV panel operating at any given working condition by applying different amounts of solar irradiance from 0 W/m<sup>2</sup> to 1000 W/m<sup>2</sup> to simulate the amount of solar irradiation at any time and everywhere on earth. This system also mimics the environment temperature by providing ambient temperature ranged from 0 °C to 50 °C to simulate the variation of weather around the year.*

**How to cite this article:** M. Q. Ali, M. S. Tapou, and H. A. Dhahad, "Performance evaluation of Photovoltaic Panels by a Proposed Automated System Based on Microcontrollers," Engineering and Technology Journal, Vol. 39, Part A, No. 01, pp. 9-21, 2021.

DOI: <https://doi.org/10.30684/etj.v39i1A.1634>

This is an open access article under the CC BY 4.0 license <http://creativecommons.org/licenses/by/4.0>

## 1. INTRODUCTION

Renewable sustainable energy sources became the focal point of scientific research and industry as an alternative for fossil and nuclear as those have an extremely negative impact on the environment for causing greenhouse effect and pollution. One of the most attractive alternatives is

solar energy due to its availability around the world [1]. Two types of solar energy conversion systems are currently available; one is the indirect energy conversion method which uses flat plate collectors to produce thermal energy. The other is direct energy conversion using photovoltaic (PV) cells to produce electrical energy. Typically, direct energy conversion is a very effective solution for renewable energy, as the incident energy of solar radiation gets converted into electricity by the photovoltaic effect. The photovoltaic effect is a phenomenon that relies on physical and chemical effects in process of creating voltage and electrical current in a material upon exposure to light [2]. At the present time, there are numerous manufacturers that produce PV panels that constitute the basic elements of a PV based power generation plant. A careful selection of the PV panels implemented is very important as the choice is very critical in deciding the reliability and service life of the intended power plant. Thus, the process of testing PV panels has become a very crucial concern due to the vast number of PV panel products available in the open market and making the right choice will have its impact on the successful erection of PV panel-based power plant. In this framework, the studies that aim to increase photovoltaic devices efficiency require testing them in a simulated environment that can emulate the environmental conditions of the places where these devices will be installed. The tests required in proofing photovoltaic panels necessitates the use of solar simulators, the light source selection for solar simulators have become a key point in the process of testing and evaluating PV products [3]. The current against voltage (I–V) characteristics of a PV panel are used to determine the panel's energy harvesting efficiency of incident solar power and this is done by supplying available load with the power generated by the solar panel under evaluation. The efficiency of power harvested from the solar cell depends on the solar irradiance incident on PV panels, the ambient temperature, and the electrical characteristics of the load. As the amount of irradiance and temperature changes, the load required for the highest power efficiency also changes. So, the throughput of the system is optimized when the load changes to keep panel efficiency at its highest. The energy harvested from the PV panel at this load is called the maximum power point (MPP). This point is allocated by the process of maximum power point tracking (MPPT) [4]. An embedded device based on a microcontroller is used to control the PV testing parameters. There are a number of advantages to using microcontrollers in case underhand. Some of these advantages are reusable, dependable, cost-effective, energy-efficient and dealing with analog and digital devices.

In this paper, a design for a fully automated PV evaluation system has been presented based on several microcontrollers to control the three main parameters that directly affect on PV panel testing scheme (load, solar irradiance and ambient temperature). This system can automatically test and calculate the MPP for any PV panel operating at any given working condition. A graphical user interface (GUI) has been provided based on the LabView platform to set up the desired parameters that can test the performance of a PV panel from dawn to dusk every day throughout the year.

## 2. RELATED WORKS

A large amount of work has been done on the subject of testing and evaluating PV panels, the following are those found being of significant relevance to the subject of the work under the hand.

In 2011, E.Cuce et al. [5] represented a controlled room with solar simulation consist of twelve 1KW tungsten-halogen bulbs placed in a hood and was mounted on the top of the test room. Light intensity is controlled manually, air conditioning system was provided to carry out the experiments under constant ambient temperature, digital ammeter and voltmeter in addition to a pyranometer were used to carry out the required measurements. A rheostat was used as a variable load. Only one solar cell was tested. In 2014, N.Kumar et al. [6] described an experimental setup to obtain the characteristic of PV cell with the help of a ready-built solar simulator, digital thermometer, and digital multimeters to measure short circuit current and open-circuit voltage. A rheostat was used as a variable load. In this work, the data logging and testing procedure were performed manually which make them prone to logging and human error. In 2015, F.Zaoui et al. [7] demonstrated an experimental setup to evaluate the electrical performance of silicon PV modules using digital multimeters to describe I-V characteristics, rheostat as a variable load, a thermometer. And a flux meter to set the intensity of the halogen light source. The test results were obtained manually, and that could result in logging errors and unnecessary long testing time. In 2017, S.Motbahhir et al. [8] presented a designed system for PV panel testing and evaluation using halogen lamps for solar

simulation and a rheostat for a load. And Arduino Uno based voltage and current measurement system using a solid-state current sensing device. A simulation has been carried out using the Proteus environment. On evaluating this work, no logging functions are provided and the light source power hasn't been declared to verify its capability to provide the necessary light intensity required for testing. In 2019, L.Lalaoui et al. [9] presented an experimental analysis for different kinds of PV panels. The indoor evaluation was done using state of the art equipment to measure and log test results. This test setup used devices that are very expensive and not attainable for all researchers.

### 3. PV PANEL TESTING SYSTEM HARDWARE

The fully automated PV testing system controls three main parameters that have a direct effect on PV panel performance. These parameters are sun irradiance, ambient temperature and applied load on the PV panels. Figure 1 shows the simplified block diagram for the designed PV panel testing system.

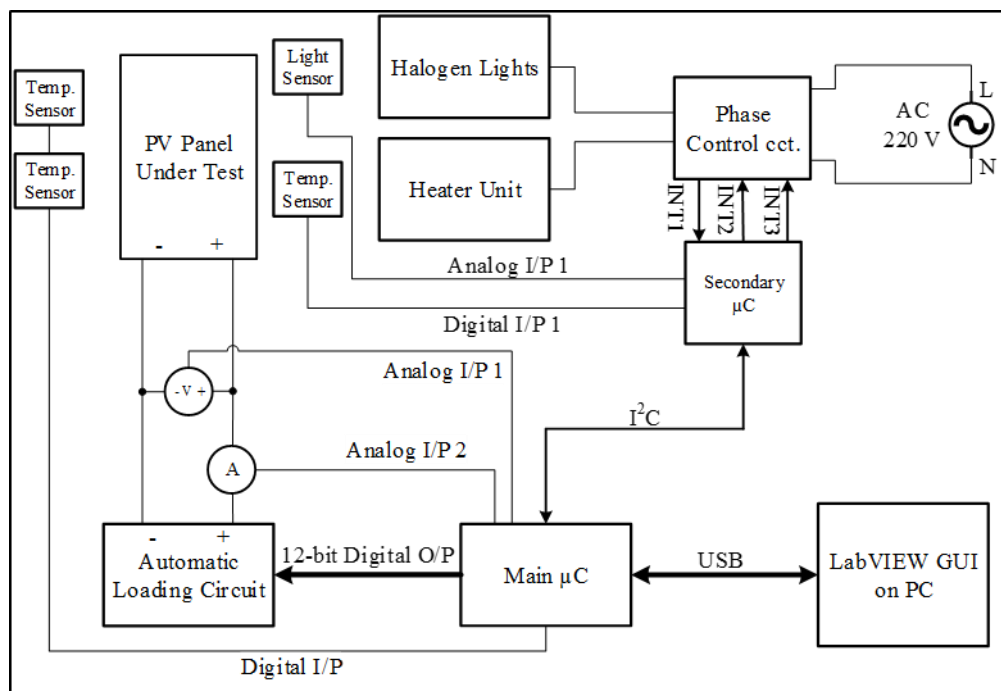

**Figure 1: Fully automated testing system block diagram**

So, it consists of the following units:

#### I. Solar intensity and Temperature control unit

This unit is comprised of two main circuits, the first one generates synchronization pulses with the mains supply frequency and essentially it is a zero-crossing detector which detects the initiation of the sinusoidal waveform of the mains supply. This signal is fed to the controlling device the ATmega 328P  $\mu\text{C}$ . This  $\mu\text{C}$  along with other circuit elements controls the triggering of two TRIAC devices independently to perform what is termed as a phase control. This function changes the AC output voltage delivered to load so as to control the light intensity of the tungsten halogen light source used to simulate the solar irradiance, and the heating element thermal output to set the ambient temperature to the desired value selected by the test condition required.

One of the most efficient ways to control mains AC power delivered to load is using phase control techniques. Usually, phase control involves using TRIACs or Thyristors as control devices [10]. In the case of the unit underhand, a TRIAC was chosen to govern the amount of AC power delivered to load by changing the effective value of the AC voltage on load (halogen lamp or heater). The switching device is turned on by applying a trigger pulse to its gate terminal after a predetermined delay within each AC half-cycle (or cycles) (every 10ms) in degree terms this

corresponds to ( $0^\circ$  to  $180^\circ$ ) and ( $180^\circ$  to  $360^\circ$ ) sinusoidal cycle. The trigger angle ( $\alpha$ ) thus is termed to when the trigger pulse is delivered to the gate terminal within each AC half cycle. Figure 2 shows the AC mains supply waveform along with the trigger pulse and the resulting load voltage waveform. The output behavior of the light intensity is shown in Figure 3.

The solar simulator control circuit receives its setpoint from the active load control system which in turn receives them from application software developed under LabVIEW environment (version 2017) as set by the user on the desktop of the control and monitoring computer. Figure 4 shows the desktop of the user interface of the testing software. The LabVIEW based application sends PV testing variables from PC to master  $\mu\text{C}$  through the peripheral USB controller operating as a serial communication port (COM3), it also receives ambient and PV temperatures, voltage, and current values from  $\mu\text{C}$  to store in excel format file and display it on the PC screen.

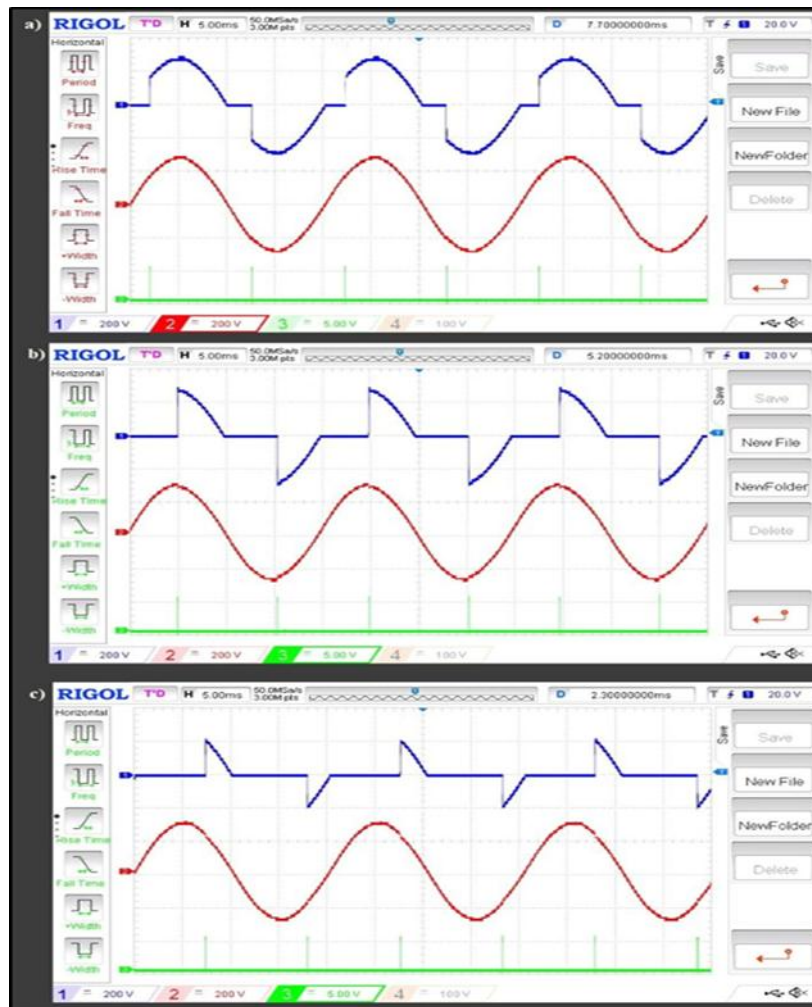

Figure 2: Input (red), trigger (green) and output (blue) waveforms of phase control when a)  $\alpha=25\%$ . b)  $\alpha=50\%$ . c)  $\alpha=75\%$ .

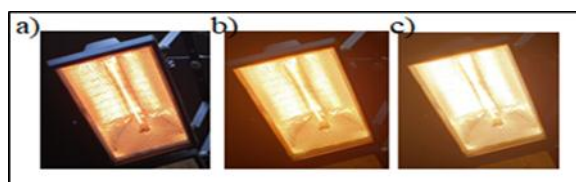
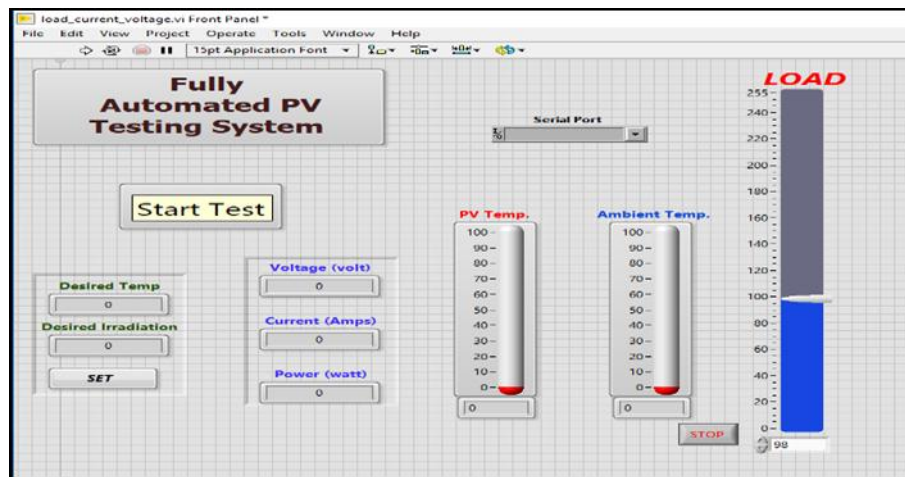

Figure 3: Output when intensity of light equal a) 25%, b) 50%, c) 75%.



**Figure 4: Graphical user interface under LabView platform**

The control action is of closed-loop type and an optical sensor monitors the generated light intensity and its output is calibrated in  $W/m^2$ . The light intensity sensor uses a Light Dependent Resistor (LDR) for circuit requirement simplicity. To increase the sensitivity and prevent sensor saturation, the light radiation should be attenuated to a specific amount. The simplest way is to use two polarizer sheets that are rotated to control the amount of incident light on LDR. The heating unit is monitored by the digital thermometer (DS18B20), these sensor readings are delivered through one wire serial communication scheme.

The controller changes trigger angle ( $\alpha$ ) so as to change the amount of electrical power delivered to halogen lamps in order for them to generate the desired light intensity, or to the heating element to change the amount of heat generated to raise ambient temperature near the desired degree Celsius. The counter/timer 1 module in the  $\mu C$  was used to generate the trigger pulses as it has two independent outputs that can be separately controlled by loading the proper value into the specific special function registers (OCR1A, OCR1B).

The Phase-Control system requires synchronization with mains ac supply. This is done by detecting the zero-crossing moment of the ac sinusoidal waveform and synchronizing the TRIAC trigger signal delayed by the required amount (the value of angle  $\alpha$ ) to deliver the required amount of power to the load. The synchronization signal is generated by the electronic circuit shown in Figure 5. The diodes D1 and D2 represent a full-wave rectifier for the center-tapped output of the isolation transformer. Transistor Q1 will turn off when the voltage applied on its base is less than approximately 0.8 V and will be turned on as this voltage passes the 0.8 V value. That will generate the zero-crossing synchronizing pulses. This output is fed to the controlling  $\mu C$  which will generate the delayed trigger pulses. A passive low pass filter provides the required immunity to noise.

The TRIAC (BTA41) is implemented for the light intensity and heater drive circuits. Isolation from the main AC voltage (220 V) is provided by the (MOC3021) opto-isolator device. It consists of an LED and a light-activated TRIAC driver. The additional RC components are snubber circuits that function as switching stress reduction devices. The complete phase control circuit is shown in Figure 5.

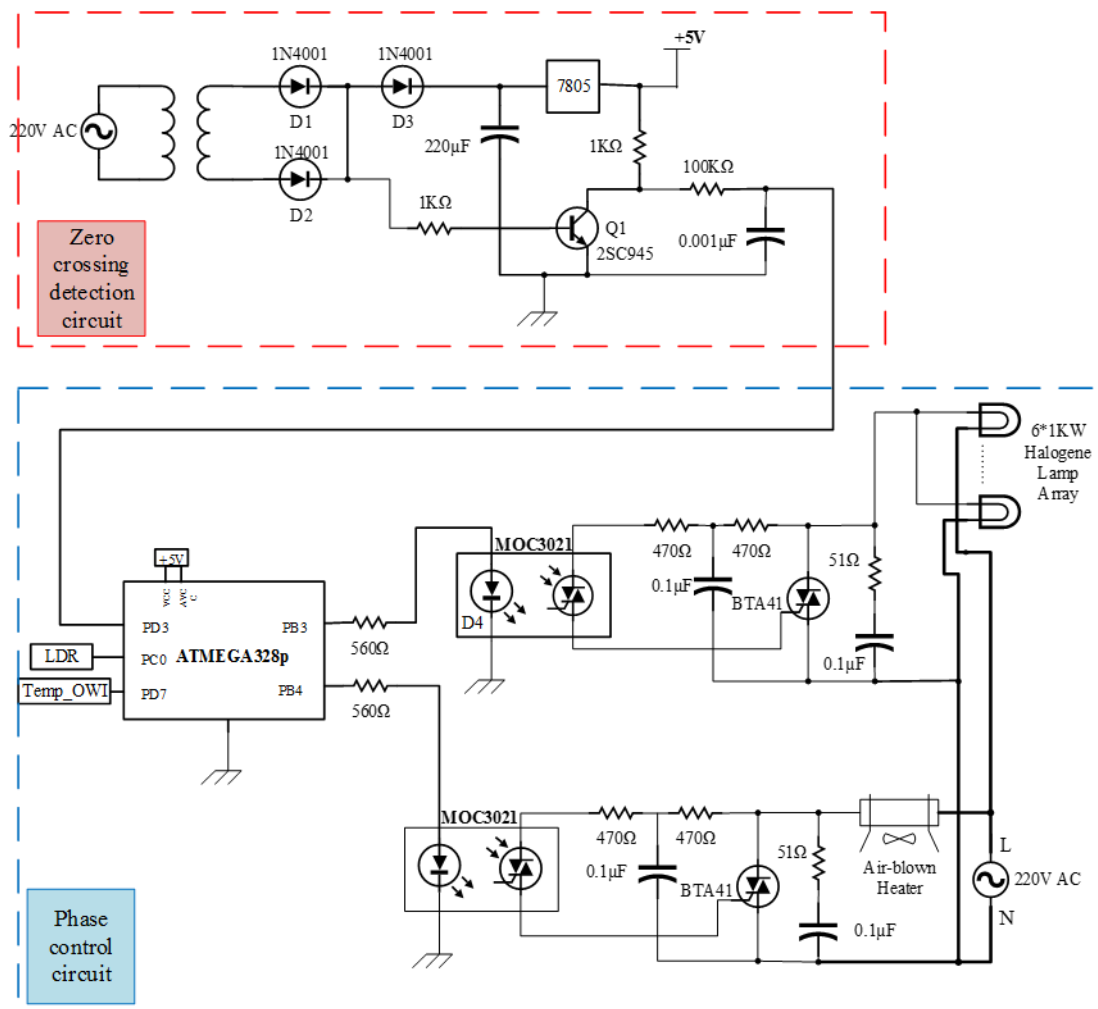

Figure 5: The complete circuit of light intensity and temperature phase control

## II. Automated PV panel-loading unit

The automated load circuit provides a variable load to the PV panel is governed by the test scheme so that the load current can be varied between 0 to  $I_{out Max}$  as per panel under test. This circuit is controlled by (STM32F103X8)  $\mu C$  which is based on ARM architecture. It generates a 12-bit digital output to the 12-bit digital to analog converter (AD7531), the output of which governs the instantaneous value of PV panel loading. To ensure the operational stability of DAC output, a high precision voltage reference is implemented using the voltage reference IC1 (LM336) which provides a precision and temperature stable voltage. The output voltage of this stage drives the active variable load circuit that is based on the power bipolar transistor "BJT" (BU931P).

The main  $\mu C$  performs additional functions; it reads the instantaneous PV panel voltage as well as current and sends them to the PC via USB. The voltage is fed to  $\mu C$  ADC through the voltage sampling divider network and a voltage follower. The current sensing circuit is designed around the ASC712 device. The ADC inside the controller provides a 12bit resolution. This  $\mu C$  reads ambient and PV panel temperatures using two DS18x20 digital temperature sensors that are connected to  $\mu C$  via a single one wire serial communication interface (OWI) as each sensor has a unique physical address. The schematic of the automated PV loading and measuring circuit is shown in Figure 6.



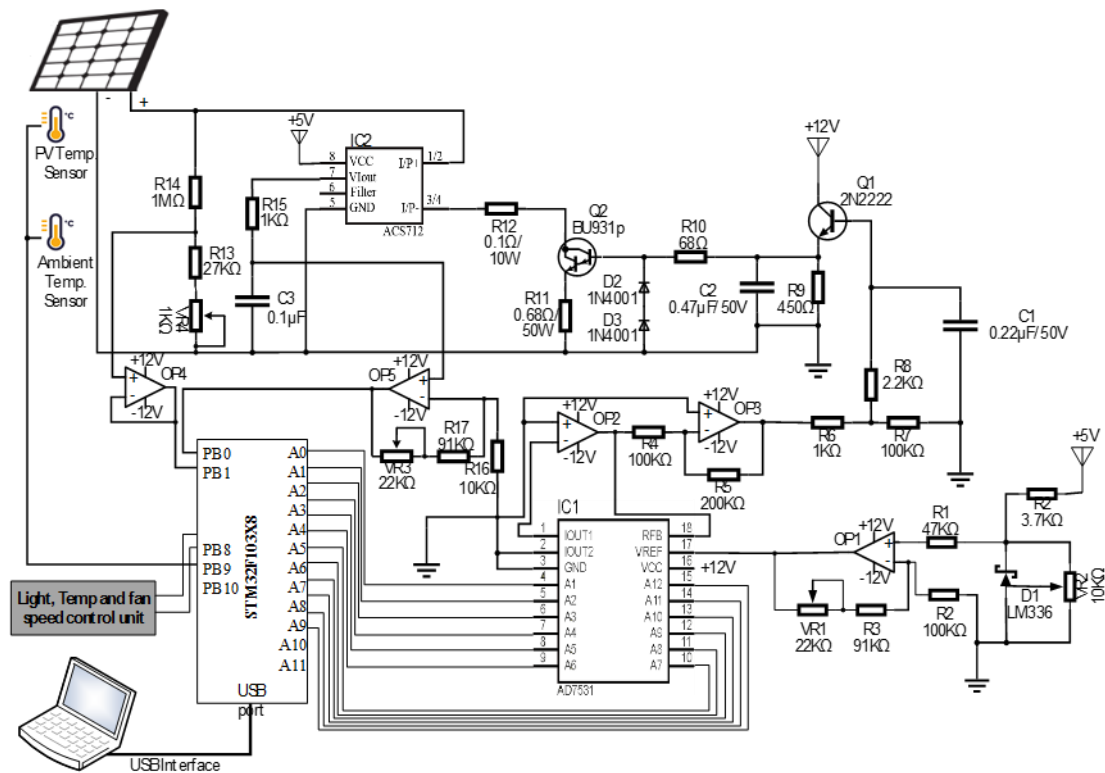

Figure 6: Automated load circuit schematic

#### 4. PV PANEL TESTING SYSTEM SOFTWARE

Two types of  $\mu$ Cs are used to implement the PV panel testing system. The main controller is a 32bit  $\mu$ C (STM32F103X8) that is based on ARM architecture; it is used to control the automatic load circuit. This  $\mu$ C has a universal serial bus (USB) peripheral that can be used to interface it to controlling and monitoring the computer. The programming of this  $\mu$ C is done using the (ST-LINK/V2), this device is an in-circuit debugger/programmer. Keil integrated development environment (IDE) was used in preparing the necessary software [11].

The written software performs the automatic loading circuit function and is integrated with a specially developed software running under a LabVIEW environment that furnishes a graphical user interface to control, log, and monitor the testing process of a PV panel. The program starts with initializing the required peripherals of the  $\mu$ C, next it executes the main program loop that sends PV testing parameters received from the GUI software to a slave  $\mu$ C interfaced via I<sup>2</sup>C controller. This slave  $\mu$ C manages the temperature and light intensity of the test chamber. The main  $\mu$ C keeps checking the test environment variables until the desired values are reached then the  $\mu$ C executes the PV loading function and determine the values of PV panel voltage and load current in 4095 steps then it sends the gathered data to the PC through the USB interface. All these values are shown simultaneously on the GUI. خطأ! لم يتم العثور على مصدر المرجع. shows the block diagram of the GUI based on the LabVIEW platform and خطأ! لم يتم العثور على مصدر المرجع. illustrates the complete flowchart of the STM32  $\mu$ C program.

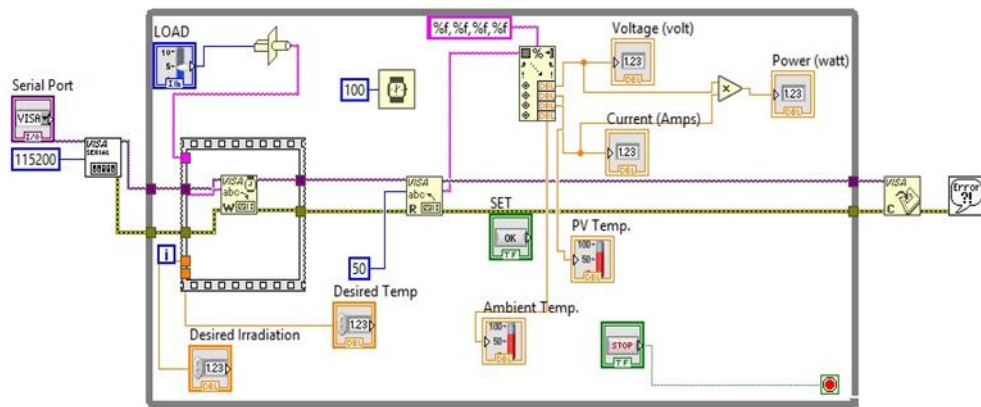

Figure 7: block diagram of the user interface application under LabVIEW.

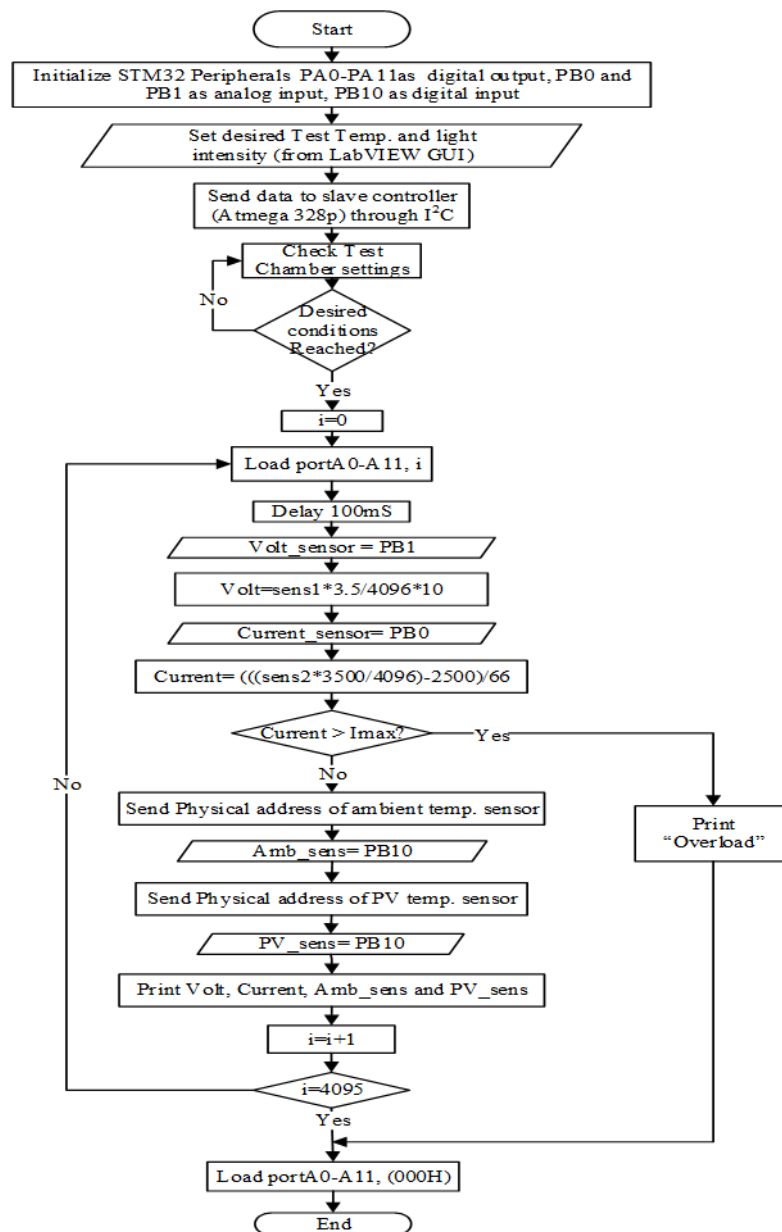

Figure 8: STM32F103X8 flowchart

The slave 8bit  $\mu\text{C}$  (ATmega 328p) is used to operate the phase control circuit that determines the intensity output of the solar simulator and the power delivered to the heating element that provides



the desired testing conditions. Programming of the secondary  $\mu\text{C}$  is done using the AVR STK 500 flash  $\mu\text{C}$  development system. The Atmel studio (version 7.0) IDE is used in developing the programs. The written software has several functions; the communication function which communicates with the main  $\mu\text{C}$ , the second function is performing closed-loop control of the solar simulator light intensity. It monitors light intensity incident on PV panel via a specially developed LDR based light meter and controls the firing angle of the phase-controlled TRIAC that supplies the required power to the halogen lamp array to deliver the desired light intensity. The third function of the software is setting test environment temperature to the desired value by controlling the power delivered to a space heating unit. A digital temperature sensor of OWI type is used to monitor test room temperature and then the firing angle of the second TRIAC is varied proportionally to furnish and maintain the desired test temperature. When the desired test conditions are met, the slave  $\mu\text{C}$  sends a status signal informing that the test condition required are met and the main  $\mu\text{C}$  can start the loading function. Figure 9 shows the flowchart of the ATmega 328p  $\mu\text{C}$ .

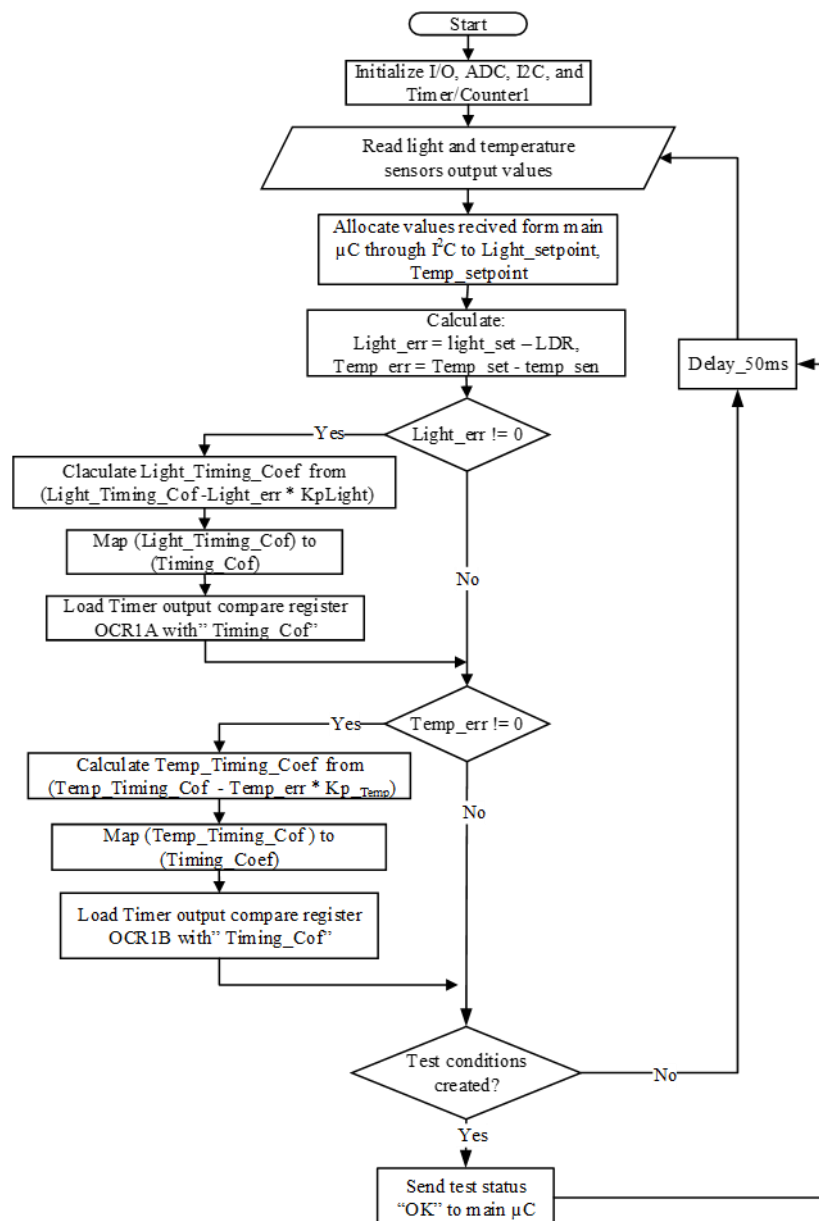

Figure 9: The flowchart of the ATmega 328p.

## 5. RESULTS

The fully automated PV panel tester designed has been subjected to several testing cycles on a Tapan solar energy PVT Inc. 80 W/ 12 V polycrystalline PV panel and results were validated against manufacturer specifications shown in to inspect measurement results accuracy, precision, and repeatability. The gathered results were identical within 0.034% which proves that this test setup has high precision. The results logged by the computer were compared with the manually obtained results that were taken using the Hameg HM8012 digital multimeter and a 50 $\Omega$ / 250W loading rheostat. The obtained results were close to 0.011% which indicates high measurement accuracy for the designed system. The conformity between the results obtained from numerous tests run for a given test condition proved that the system has a high degree of repeatability.

The PV panel being tested has been subjected to further repeated test cycles under different irradiances and temperatures inside the test chamber to simulate the effect of sunlight irradiance variation on PV panel output power throughout one calendar year in order to plot power – voltage curve and tracking the MPP of this panel a year around.

The first part of the test showed the effect of solar irradiation on the PV panel behavior, by taking three different irradiances (300 – 500 – 800) W/m<sup>2</sup> while the ambient temperature was set to 25°C.

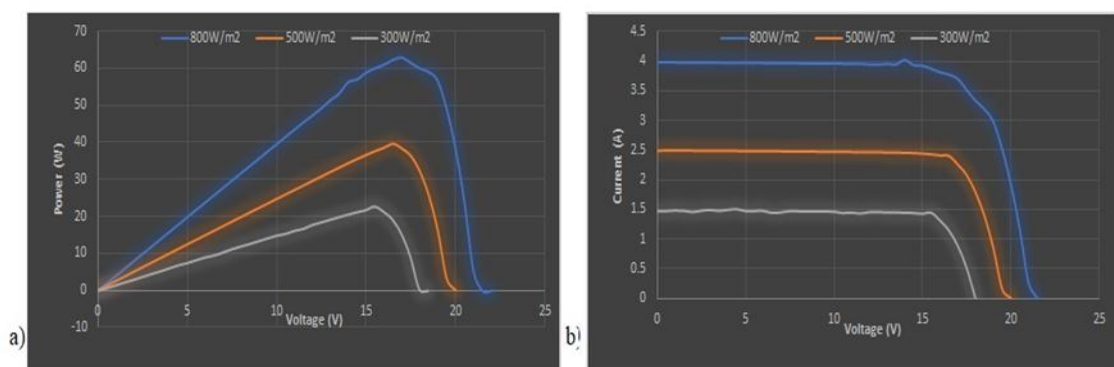

**Figure 10: (a) voltage – power curve. (b) voltage – current curve with the variation of solar irradiance.**

As shown in Figure. 10 the increase of irradiance leads to an increase in the output power of the PV panel as the irradiance increases the number of free electrons released resulting in increased open-circuit voltage and increased short circuit current.

The second part of the test demonstrates the effect of temperature variation on PV panel behavior by taking three different temperature settings (25°C, 35 °C, 45 °C) with fixed irradiance equal to 1000 W/m<sup>2</sup> to visualize the effect of increased ambient temperature on the output power of PV panel under test. It has been established that an increase in environmental temperature leads to a decrease in open-circuit voltage and this decreases output power. The rise in environmental temperature has the effect of increasing the close-circuit current but in a marginally smaller proportion which will have no contribution to a noticeable increase in PV panel power output as seen in Figure 11.

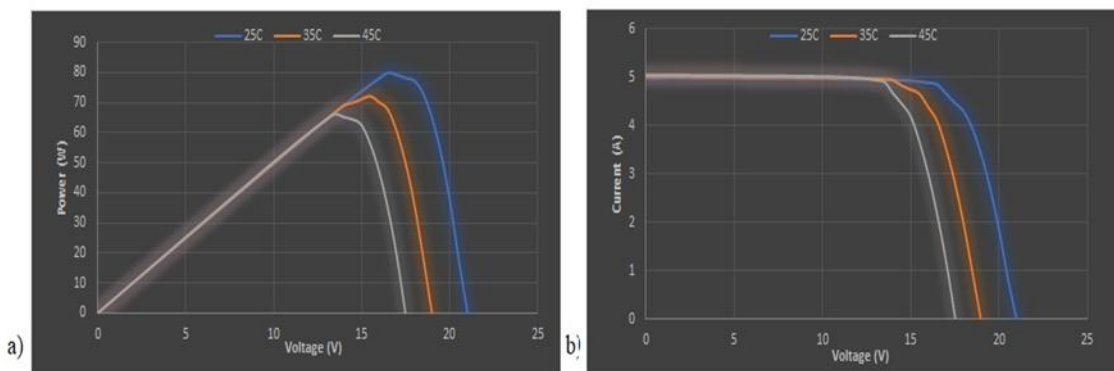

**Figure 11: (a) P-V curve with (b) I-V curve with the variation of temperatures.**

To validate the performance and functionality of the designed test chamber, a comparison was made between the experimental results and MATLAB simulation result [12] as shown in Figure 12. These comparisons are shown in Figure 13.

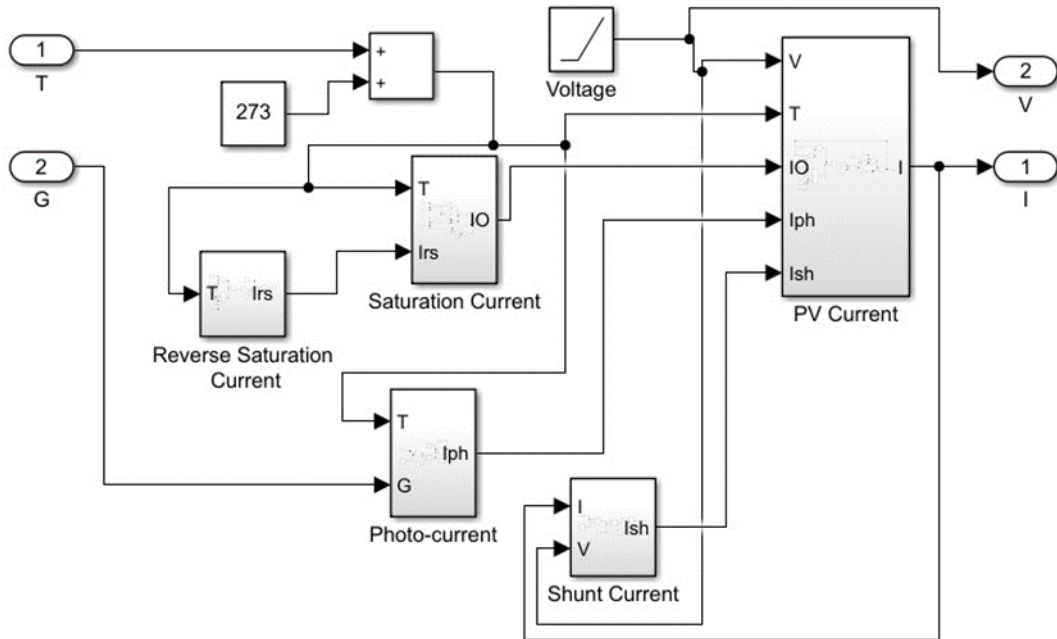

Figure 12: MATLAB Simulink based simulation of a PV panel model

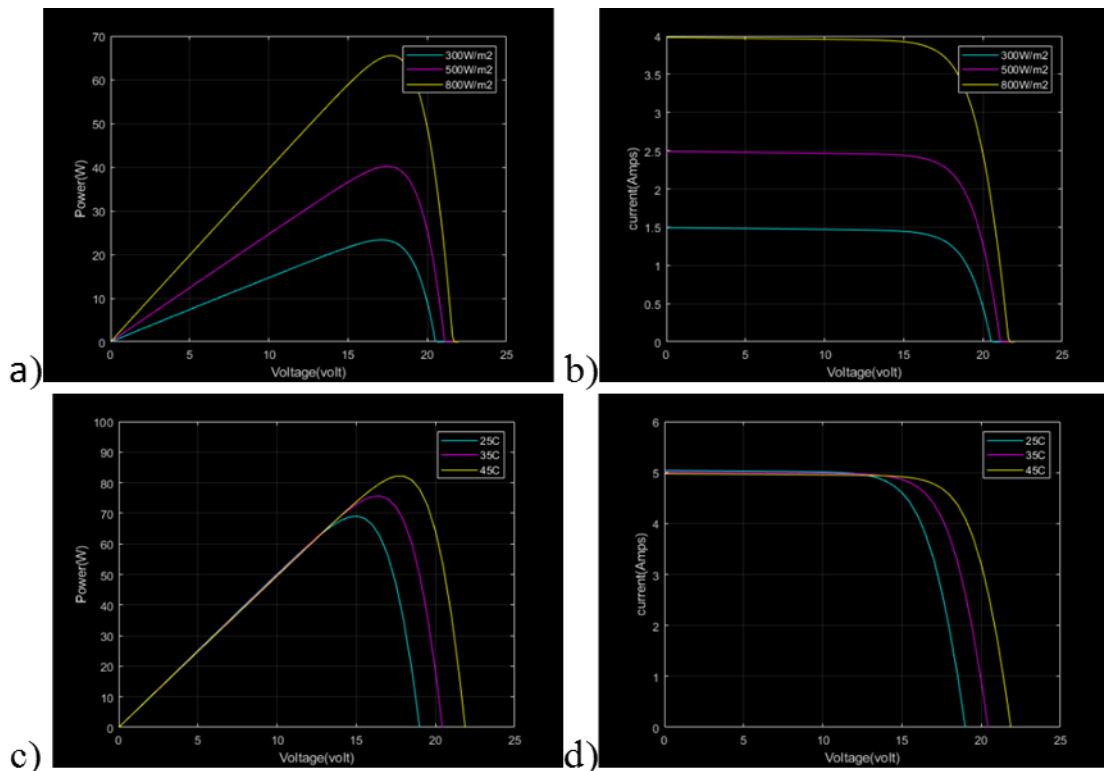

Figure 13: simulation result (a) P-V curve with the variation of irradiation. (b) I-V curve with the variation of irradiation. (c) P-V curve with the variation of temp. (d) I-V curve with the variation of temp

The results of these comparisons were of good conformity and within -3% of MATLAB estimated values.

For more validation, other PV panels from several manufacturers were put to the evaluation process using the designed testing system. Table 1 shows the divergences obtained from testing results, simulation results, and the manufacturer's provided parameters. These panels were also subjected to a manual test.

**TABLE I: The discrepancies from manufacturer specifications, simulation results, and testing results.**

PV Panel	Parameters	Manufacturer specifications	Simulation results	Experimental results
<i>Monocrystalline module 300W-72M From Tenka Solar</i>	Pmax	300 W	300.62 W	297.8 W
	Vmp	37 V	37 V	36.75 V
	Imp	8.11 A	8.12 A	8.10 A
<i>Multicrystalline Bp MSX 120 solar panel array</i>	Pmax	120 W	122.7 W	117.2 W
	Vmp	33.7 V	35 V	33.12 V
	Imp	3.56 A	3.50 A	3.53 A
<i>Solarex MSX60 Polycrystalline Photovoltaic module</i>	Pmax	60 W	59.79 W	57.89 W
	Vmp	17.1 V	17 V	16.88 V
	Imp	3.5 A	3.517 A	3.43 A

The results proved that those obtained from the implemented automatic PV testing system are highly dependable and accurate. The minor discrepancies found between these results due to the connection and other electrical losses.

The described PV testing system has the characteristics shown in Table 2.

**TABLE II: Characteristics of PV panel testing system.**

Term	Range	resolution	error
<i>PV Nominal voltage</i>	12 V / 24 V	-	-
<i>Measured O/P voltage</i>	0 V to 40V	9 mV	±4.5 mV
<i>Measured O/P current</i>	0 A to 15 A	3.67 mA	±1.8 mA
<i>Light intensity output</i>	0 to 1000W/m <sup>2</sup>	0.25W/m <sup>2</sup>	± 0.125 W/m <sup>2</sup>
<i>Test temperature</i>	0 °C to 50 °C	1 °C	± 0.5 °C

The current measuring range can be set to read (30 A) max with a simple modification.

A comparison between the implemented prototype in this paper and the S. Motahhir prototype [8] has been presented in Table 3.

**TABLE III: Fully automated testing system and S. Motahhir testing system comparison.**

Type	Implemented Fully automated testing system	S. Motahhir prototype [8]
<i>Microcontroller</i>	STM32F103X8 $\mu$ C	Arduino module
<i>ADC</i>	12-bit	8-bit
<i>Current resolution</i>	3.67 mA	58.6 mA
<i>Voltage resolution</i>	9 mV	136.7 mV
<i>Solar simulator</i>	8 halogen lamp projectors array with phase control circuit	Single LED projector without controlling scheme
<i>Ambient temperature</i>	Heating system with phase control circuit	None
<i>Load applied</i>	Automatic load system	Rheostat
<i>User interface</i>	PC with special proposed GUI based on LabView.	16 $\times$ 2 LCD

## 6. CONCLUSIONS

The general objective of this work is demonstrating the effect of the environment on the efficiency of PV panels, and the analysis of various parameters that can contribute to the optimization of its energy efficiency. The optimal operation of the photovoltaic module is closely related to the climatic conditions on one hand and the load used on the other. To optimize PV performance, it is necessary to mimic the meteorological parameters of the geographical location that the PV panel is to

be deployed on. For this purpose, a high-performance standard PV testing system has been designed and implemented. It has an accuracy of  $\pm 0.013\%$  of full scale, a precision figure of 99.97%, and a resolution of 9 mV / 1.8 mA. These measurement performance figures are sufficient to test any PV panel of 12 V and 24 V rating. The power output of the PV panel can be measured at a setting simulating the intended deployment area environment (from 0 °C to 50 °C) to assist in estimating the required number of PV panels needed to provide the proposed power output of the plant at a given location. This automated PV testing system can provide any solar light intensity at any time everywhere in the world with a range of 0W/m<sup>2</sup> to 1000 W/m<sup>2</sup>. The logged testing data assists in evaluating PV panel performance and to estimate the MPP of the panel for the development of better power management schemes and systems. Finally, the approximate duration required to evaluate a PV panel is under 7 minutes for any environmental setting.

## References

- [1] G. Wang, Technology, "Manufacturing and Grid Connection of Photovoltaic Solar Cells," USA: JohnWiley & Sons, 2018.
- [2] O.Dupré, "Physics of the thermal behaviour of photovoltaic devices," Ph.D. Thesis, INSA, Lyon, 2015.
- [3] V.Esena, Ş.Sağlamb and B.Oralb, "Light sources of solar simulators for photovoltaic devices: A review," Renewable and Sustainable Energy Reviews, vol. 77, pp. 1240-1250, March 2017.
- [4] M.A.G.Brito, L.P.Sampaio, L.G.Junior and C.A.Canessin, "Evaluation of MPPT Techniques for Photovoltaic Applications," IEEE International Symposium on Industrial Electronics, pp. 1039-1044, June 2011.
- [5] E.Cuce, T.Bali and S.A.Sekucoglu, "Effects of passive cooling on performance of silicon photovoltaic cells," International Journal of Low-Carbon Technologies, vol. 0, pp. 1-10, Sep. 2011.
- [6] N.Kumar, S.Gawre and D.Verma, "Modeling and Simulation of Solar Photovoltaic System and Interfacing with Neutral Point clamped Multilevel Inverter," proceeding of International Conference in Electrical, Electronics and Computer Science, Chennai, 2014.
- [7] F.Zaoui, A.Titaouine, M. Becherif and M. Emziane, "A combined experimental and simulation study on the effects of irradiance and temperature on photovoltaic modules," proceeding of The 7th International Conference on Applied Energy, Algeria, 2015, pp. 373 – 380.
- [8] S.Motahhir, A.Chalh, A.El-Ghzizal, S.Sebti and A.Derouich, "Modeling of Photovoltaic Panel by using Proteus," Journal of Engineering Science and Technology Review, vol. 10, pp. 8-13, June 2017.
- [9] L. Lalaoui1, M. Bouafia, S. Bouzid, M. Kugler, M.Zentgraf, P. Schinköthe, and S. Nieland, "Indoor and Outdoor Measurements of PV Module Performance of Different Manufacturing Technologies," Springer Nature Switzerland, p. 238–250, 2019.
- [10] M.H.Rashid, "Power electronics handbook," California: Academic Press, 2001.
- [11] STMicroelectronics, "ST-LINK/V2 in-circuit debugger/programmer for STM8 and STM32," UM1075 User Manual, 2018.
- [12] K. Dubey and M.T.Shah, "Design and Simulation of Solar PV," in International Conference on Automatic Control and Dynamic Optimization Techniques , Pune, 2016.