

Rashid H. Al-Rubayi

Electrical Engineering
Department, University of
Technology\Baghdad
Baghdad, Iraq
dr.rashid56@yahoo.com

Mohammed B. Eese

Electrical Technics
Department, Al-Suwaira
Technical Institute, Middle
Technical University
Baghdad, Iraq
eng.mohb14@gmail.com

Received on: 27/07/2016
Accepted on: 27/04/2017
Published online: 25/01/2019

Optimal Location and Parameter Setting of STATCOM Device Based PSO for Iraqi Grid Voltage Profile Enhancement and Power Losses Minimizing

Abstract- The main goal of this work is to enhance the Voltage stability by using optimum location and parameters setting of STATCOM device. The parameters are the magnitude of the output voltage V_{VR} and the angle δ_{VR} , these parameters are taken to control the device performance. The simulation results have been done by using power flow program solution by Newton-Raphson method (Matlab program / M-file) with Particle Swarm Optimization (PSO) technique, for power losses minimizing and improving voltage profile. Two systems have been implemented:- IEEE 5-bus test system and Iraqi (400 kV) National super Grid System 27-bus. The MATLAB programs are Applied in the first step on IEEE 5-bus test system to examine the performance of the programs by comparing the results with other references, then it is implemented on Iraqi (400 kV) National super Grid System to find optimum location and parameter setting of STATCOM device. The results show that, the STATCOM has significant effect on improving the voltage profile and reducing apparent power losses, The STATCOM device performance depends on its location and parameter settings, and The PSO algorithm can easily find out the optimal location and parameters setting of the STATCOM for which the voltage deviation are minimum.

Keywords: FACTS, STATCOM, Optimal location and parameters setting of STATOM

How to cite this article: R.H. Al-Rubayi and M.B. Eese, "Optimal Location and Parameter Setting of STATCOM Device Based PSO for Iraqi Grid Voltage Profile Enhancement and Power Losses Minimizing," Engineering and Technology Journal, Vol. 37, Part A, No. 1, pp. 60-69, 2019.

1. Introduction

Power system stability is the most concern part in all power system networks. It is well-defined as the power system property that enables it to stay in a status of an operating equilibrium at the regain an suitable status of equilibrium after being exposed to a disturbance and normal condition . Stability of power system is categorized into: Small signals stability and Transient stability. Transient stability is the capability of power system to keep synchronism when exposed to a high disturbance and to recover a status of equilibrium following the subjected disturbance. Small signals stability is the capability of the power system to hold out disturbances or small changes without synchronism loss amongst the synchronous machines contained in the system, while having a suitable damping of the system oscillation [1]. Today's power systems are vastly interconnected among different areas and countries for commercial reasons to increase reliability and reduce the cost. But more and more complicate power systems can become less protected because of outsized dynamic swings, excessive reactive power system and insufficient power flow control

which grow into bottlenecks of complete utilizing the transmission interconnections potential. The Flexible AC Transmission Systems (FACTS) technologies is effective on alleviating these problems, and increase both transient and small signal stability margins [2]. Even though considerable amount of research work was done in the area of optimal location of STATCOM and STATCOM uses in power system stability [3to 15], therefor this work to find optimal location and parameters setting of STATCOM for enhancing voltage stability and power losses minimizing. In this work, particle swarm optimization (PSO) will be used to find the optimal location and parameters setting of Static Synchronous Compensators (STATCOM's) for the Iraqi National super Grid system INSGS (400kV). The aim is to reduce the power system losses by controlling power flow through the transmission lines, and also, reducing the deviation of the voltages from their specified values for improvement of the voltage profile across the load nodes. Then number of STATCOMs is selected by enhancement of voltage stability under power system disturbances (many types of disturbances).

2. Problem Formulation

I. Operation Principle and basic concept of STATCOM

STATCOM is a second class FACTS-device used for shunt reactive power compensation. It is based on the principle that a self-commutation inverter can be connected between controlled 3-phase AC power lines to draw mainly reactive current from transmission lines. The current can be controlled to be either inductive or capacitive and is almost not influenced by the line voltage. Therefore it provides much best performance of reactive power compensation over the conventional SVC [5].

The main benefits of STATCOM are:

- Interface with a real power source
- Higher response to system variations.
- Harmonics mitigation.
- Superior low - voltage performance.

Figure 1 shows STATCOM device of voltage type self-commutation full-bridge inverter corresponding to power-electronics theory. The capacitor DC - voltage acts as an ideal DC - voltage source to support inverter. The regular diode is linked in the opposite-parallel direction with the GTO is a path for continuous current, providing route for the feedback - energy from the AC - side. The inverter usual operation is to convert the DC voltage into AC - voltage having controllable magnitude and phase angle at the same - frequency as the AC - system [16].

II. Objective function optimization

The optimal settings for controlling the variables in a power system with respect to various constraints became a case of interest in the last decades. Many optimization tools have been introduced to provide solutions for a wide range of power systems problems for different objectives [17]. Three objective functions are considered in this thesis, which are the voltage deviation VD and apparent power losses S_{losses} (system security and service quality) .These objective functions can be summarized as follows:

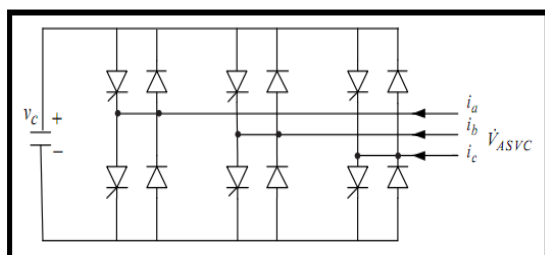

Figure 1: Circuit of STATCOM

1. Apparent Power Losses

The apparent power loss (S_{losses}) of the transmission line is one of the major objectives for the optimization problem in the electrical power system when it is gather their two components active power and reactive power in one formula. Then the total power losses of the transmission-lines are given as:

$$S_{losses} = \sum_{i=1}^{Ntl} (S_{si} + S_{ri}) - \left(\frac{B_i}{2} (V_{si} + V_{ri}) \dots (1) \right)$$

where: Ntl is the number of transmission lines, S_{losses} is the total power losses, S_{ri} and S_{si} are the received and send apparent power flow of the line i, respectively, B_i the susceptance of the π -model transmission line-i and V_{ri} and V_{si} the are the received and send voltage-magnitude of the line - i.

2. Voltage-Deviation (VD)

The bus voltage is one of the most important which improves the voltage profile, service quality indexes and security. Therefore, minimizing the voltage-drop will increase the security of system. The VD of the system is given as [18,6]:

$$VD = \left\{ \sum_i^{nbb} (V_i - 1)^2 \right\}^{1/2} \dots \dots (2) \quad \text{where:}$$

V_i voltage magnitude at bus - i, ND is the number of load buses and V_i^{sp} specified voltage magnitude at bus-i.

3. Multi-Objective Function

The objective-function f in eq. (3.14) is a weighted sum of the voltage deviation and apparent power losses. The value of the two term in the objective-functions are similar; the weighting-factor is determined by error and trial to equality of this terms. The apparent power losses and voltage-deviations are considered in p.u[6].

$$f = w_{m1} * S_{losses} + w_{m2} * VD \dots \dots (3) \quad \text{where: } f \text{ is the objective function value and } (w1, w2) \text{ are weighting factor}$$

III. Mathematical Representation of STATCOM

The power flow equations of the STATCOM device are derived from basic principles, assuming the representation of the voltage source as the follows:

$$E_{VR} = V_{VR} (\cos \delta_{VR} + j \sin \delta_{VR}) \dots \dots (4)$$

Created on the shunt connection as shown in Figure (2), it may be written as follows: $S_{VR} = V_{VR} I_{VR}^* = V_{VR} Y_{VR}^* (V_{VR}^* - V_K^*) \dots \dots (5)$

After performing some complex operations, the following equations of the active and reactive power are obtained for the bus k and converter, respectively: The STATCOM - device will be

well appear by synchronous voltage-source with minimum and maximum voltage magnitude limits. The synchronous voltage - source represents the fundamental Fourier series components of switched voltage waveform at AC - converter terminal of STATCOM-device. STATCOM is exemplified as a voltage-source of the full range for operation, and enables a more robust mechanism of voltage support. The equivalent-circuit of STATCOM device shown in Figure 2 is used to derive mathematical model of this controller for inclusion in power flow algorithms.

$$P_k = V_k V_{VR} [G_{VR} * \cos(\theta_k - \delta_{VR}) + B_{VR} * \sin(\theta_k - \delta_{VR})] + V_k^2 * G_{VR} \dots \dots (6)$$

$$Q_k = V_k V_{VR} [G_{VR} * \sin(\theta_k - \delta_{VR}) - B_{VR} * \cos(\theta_k - \delta_{VR})] - V_k^2 \dots \dots (7)$$

$$P_{VR} = V_{VR} V_k [G_{VR} * \cos(\delta_{VR} - \theta_k) + B_{VR} * \sin(\delta_{VR} - \theta_k)] + V_{VR}^2 * G_{VR} \dots \dots (8)$$

$$Q_{VR} = V_{VR} V_k * [G_{VR} * \sin(\delta_{VR} - \theta_k) - B_{VR} * \cos(\delta_{VR} - \theta_k)] - V_{VR}^2 * B_{VR} \dots \dots (9)$$

Using these power equations, the linearized STATCOM model is given below, where the voltage magnitude V_{VR} and angle δ_{VR} are taken to be the state variables [19]

$$\begin{bmatrix} \Delta P_k \\ \Delta Q_k \\ \Delta P_{VR} \\ \Delta Q_{VR} \end{bmatrix} = \begin{bmatrix} \frac{\partial P_k}{\partial \theta_k} & \frac{\partial P_k}{\partial V_k} V_k & \frac{\partial P_k}{\partial \delta_{VR}} & \frac{\partial P_k}{\partial V_{VR}} V_{VR} \\ \frac{\partial Q_k}{\partial \theta_k} & \frac{\partial Q_k}{\partial V_k} V_k & \frac{\partial Q_k}{\partial \delta_{VR}} & \frac{\partial Q_k}{\partial V_{VR}} V_{VR} \\ \frac{\partial P_{VR}}{\partial \theta_k} & \frac{\partial P_{VR}}{\partial V_k} V_k & \frac{\partial P_{VR}}{\partial \delta_{VR}} & \frac{\partial P_{VR}}{\partial V_{VR}} V_{VR} \\ \frac{\partial Q_{VR}}{\partial \theta_k} & \frac{\partial Q_{VR}}{\partial V_k} V_k & \frac{\partial Q_{VR}}{\partial \delta_{VR}} & \frac{\partial Q_{VR}}{\partial V_{VR}} V_{VR} \end{bmatrix} \dots (10)$$

IV. Implementation of STATCOM Device in N.R Power Flow Algorithm

The algorithm for solution of a problem of power flow embedded with STATCOM device is applied by using the MATLAB program. The N.R power flow algorithm incorporating the STATCOM device is shown by flow chart in Figure (3). The input system data contains the basic system data desired for conventional power flow computation consisting of the bus, generation, transmission line, load and STATCOM data. This work proposes applying PSO-technique to find out optimal location and parameter setting of STATOM-devices for Iraqi Grid Voltage Profile Enhancement.

Particle Swarm Optimization (PSO)

1. Introduction

The (PSO) as an optimization tool gives a population based search method in which persons named particles vary their location (state) with time. In a PSO - system, particles fly round in a multi-dimensional search space. During flying, each particle determine its location matching to its personal knowledge, this value is named p_{best} , and according to the knowledge of an adjacent particle This value are named G_{best} , making use of the better location encountered by its neighbor and itself (Figure 3).

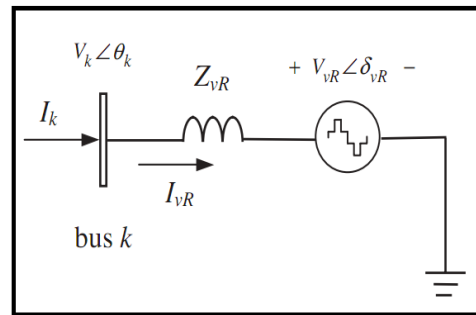

Figure 2: STATCOM equivalent circuit

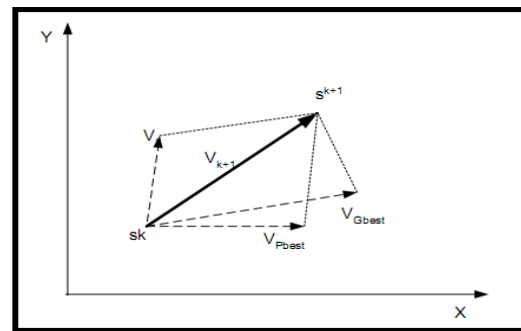

Figure 3: Concept of a searching point in PSO

This modulation can be explained by the concept of velocity. Velocity of each deputy can be modified by the following equation:

$$V_{id}^{k0+1} = wV_{id}^{k0} + C_1 * \text{ran}(pbest_{id} - X_{id}^{k0}) + C_2 * \text{ran}(gbest_{id} - X_{id}^{k0}) \dots \dots (11)$$

$$X_{id}^{k0+1} = X_{id}^{k0} + V_{id}^{k0+1} \quad i = 1, 2, 3, \dots, n \dots \dots (12) \quad d = 1, 2, \dots, m$$

where, X_{id}^{k0} and X_{id}^{k0+1} are current and modified searching point respectively, V_{id}^{k0} and V_{id}^{k0+1} are current and modified velocity respectively, V_{pbest} and V_{gbest} are velocity based on p_{best} g_{best} respectively, n and m are number of the particles in a group and members in a particle respectively, P_{besti} The butter position of the i th particle g_{besti} The best particle among all the particle in the group w_i the weight - function velocity of the agent i , c_i the weight - factors for each term. The following weight function is used:

$$w_{(i)} = w_{\max} - \left(\frac{w_{\max} - w_{\min}}{k_{o\max}} \right) * k_o \dots\dots (13)$$

Where w_{\max} and w_{\min} are the max and min weights respectively. $k_{o\max}$ and k_o are the max and current iteration.

2. Particle Swarm Optimization (PSO) Compared with the Traditional Optimization Algorithms

a. It only needs a fitness function to evaluate the (quality) of a solution instead of complex mathematical operations like Hessian, matrix inversion or, gradient. This decreases the computational complexity and reduces some of the limits that are usually forced on the objective-function similar to continuity, convexity, or differentiability.

b. It is less complex to a good primary solution since it is a population-based procedure.

c. It can be simply merged with other optimization tools for structure hybrid ones.

d. It has the capability to escape local minimum since it

follows probabilistic rules of transition.

e. More interesting (PSO) benefits can be stressed when compared to other member-ships of evolutionary algorithms similar to the following.

f. It can be easily modified and programmed with basic mathematical concept and logic operations.

g. It is inexpensive in relation with computation time and memory.

h. It requires less regulation of parameter.

I. It workings with direct actual-valued numerals, which remove the need to do conversion of binary of a traditional canonical genetic algorithm.

3. Implementation of PSO :

The PSO based approach to solves the optimum locations and parameters settings steps are summarized in Figure 4 [18]. Figure 5 represents flow chart of PSO and load flow by N-R with

STATCOM respectively.

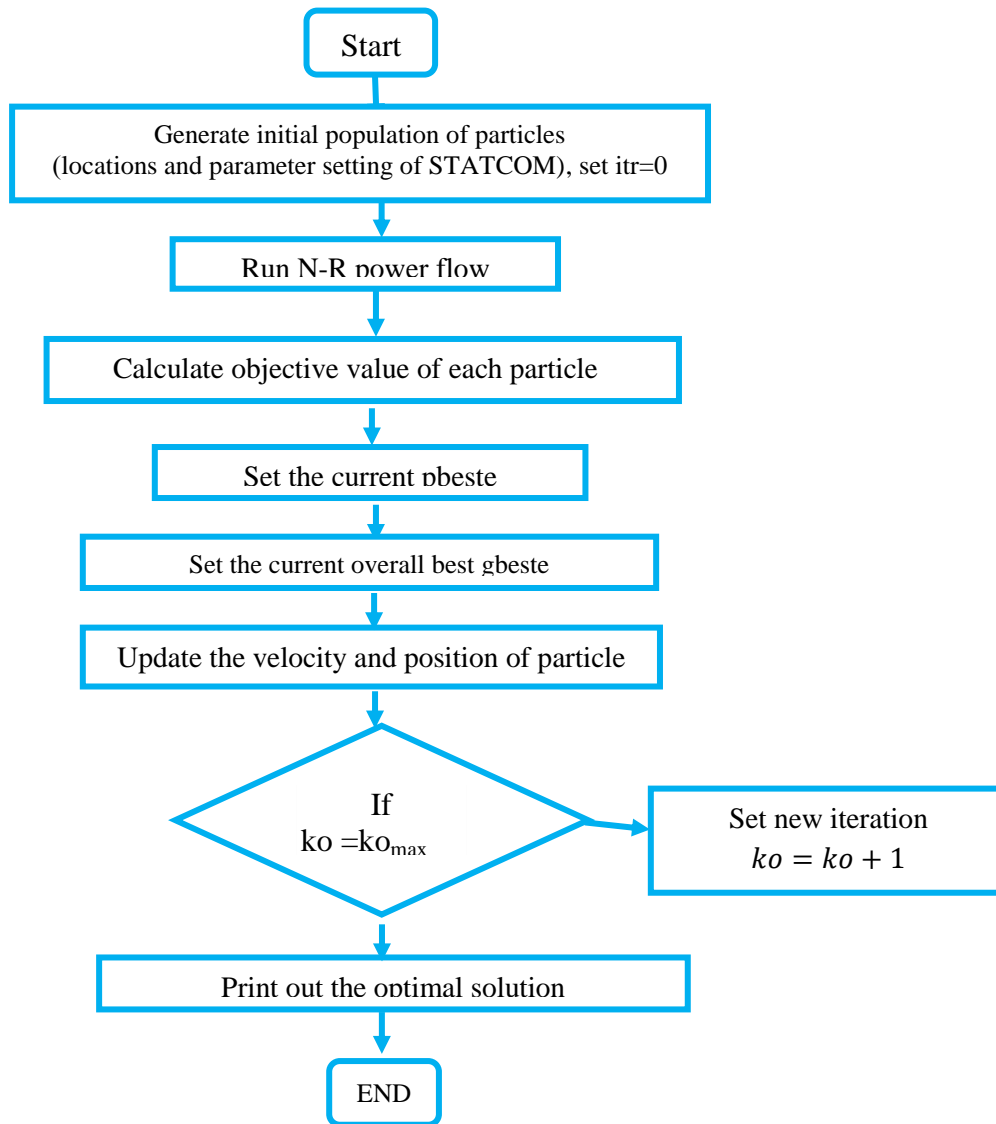

Figure 4: Flowchart of PSO

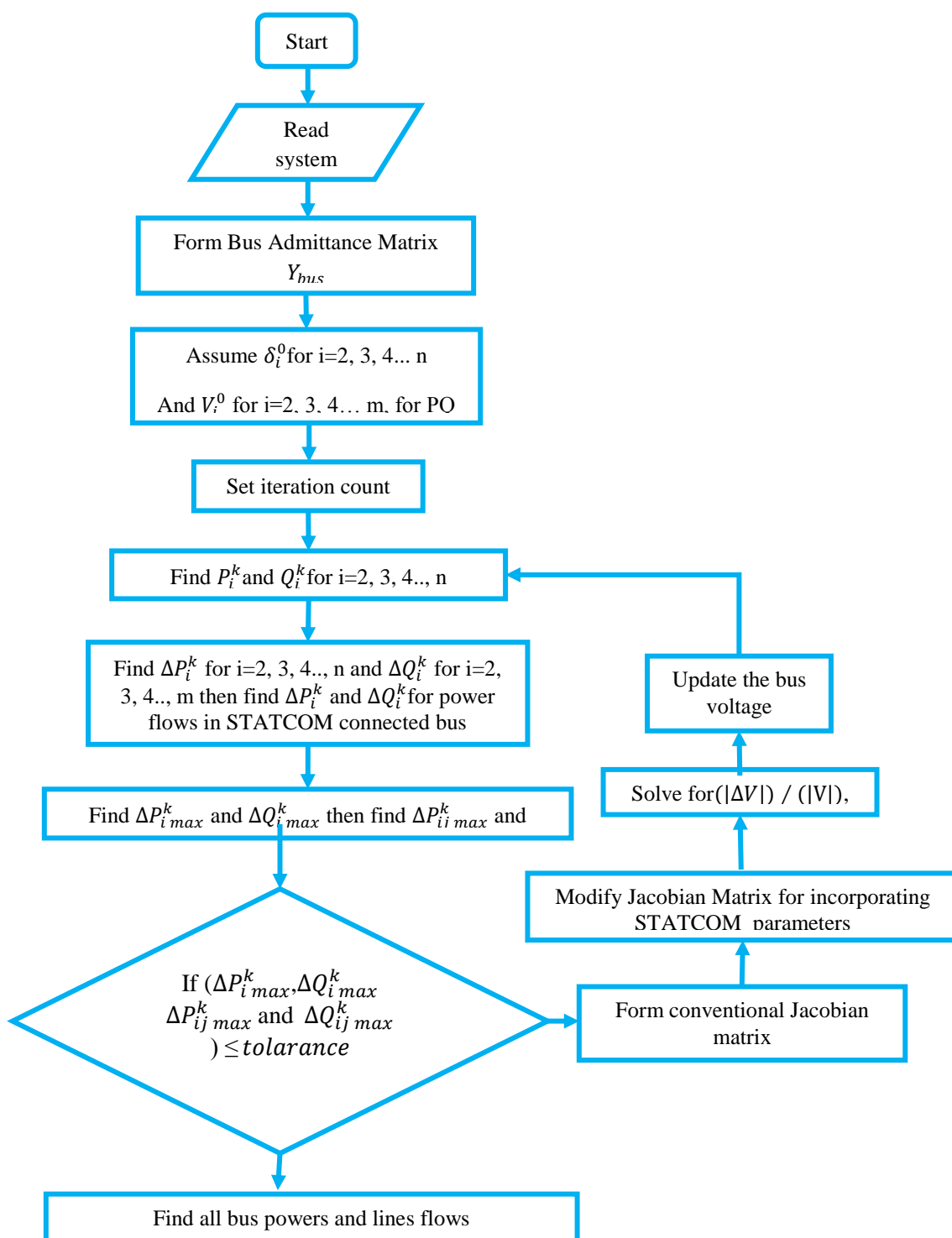

Figure 5: Flowchart of load flow by N-R with STATCOM

3. Simulation Results and Discussion for case study:

The main goal of this work is to enhance the power system stability by using optimum location and parameters settings of STATCOM device. The parameters are the magnitude of the output voltage V_{VR} and the angle δ_{VR} , these parameters are taken to control the device performance. The simulation results have been obtained by using PSO technique with power flow program solution by N-R method, for power losses minimizing and improving voltage profile. Two systems are considered in this work, the IEEE 5-bus test system and the INSGS (400kV). The data of these systems are given in references [18,20] respectively .

Cases Study

This work takes into account the summer season in studying the three separated cases because the reactive power maximum condition. The number of the installed STATCOM devices in each time are one, two, three and four applied on INSGS (400kV), but for IEEE 5-bus test system apply one STATCOM only. Three preference conditions for each STATCOM devices are achieved according to each objective function below:

1. Case1: minimizing the apparent power losses.
2. Case2: minimizing voltage deviation.
3. Case3: minimizing both the apparent power losses and voltage deviation.

IEEE 5-bus test System

The single line diagram of IEEE 5-bus test system is shown in Figure 6 this system contains 2 generators 4 loads and 7 transmission lines.

Table1 shows the optimum location and parameter settings of STATCOM for IEEE 5-bus test system using PSO technique. While Table.2 shows a comparison of the result of the system with and without STATCOM device. These results are used to examine the performance of the program in comparison with the results of reference [18].

Table 2 show that the STATCOM improves the voltage profile which occurs with reducing the voltage deviation by 64.5%. In addition the use of the STATCOM attain reducing the apparent power loss by 25.54%. A comparison between the results obtained from the proposed method of STATCOM placement for IEEE 5-bus test system, and those given in reference [20] shows that there is a good agreement between them and the results acquired from the proposed method best than results of reference [20] because of influence of parameters setting of STATCOM.

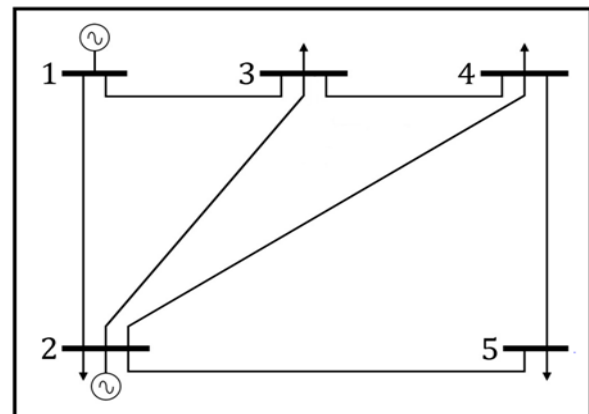

Figure 6: single line diagram of IEEE 5-bus test system

Table 1: The Optimum location and parameter settings of STATCOM for IEEE 5-bus test system

CASE	VD (p.u)	S_{LOSS} (p.u)	Optimum location of STATCOM (at bus)	Optimum settings of STATCOM V_{VR} (p.u)	δ_{VR} (rad)
Without STATCOM	0.0569	0.1595	-----	-----	-----
CASE1	0.0583	0.1124	5	0.9	1.3438
CASE2	0.0182	0.1190	5	0.95	1.3438
CASE3	0.0202	0.1188	5	0.93	1.3264

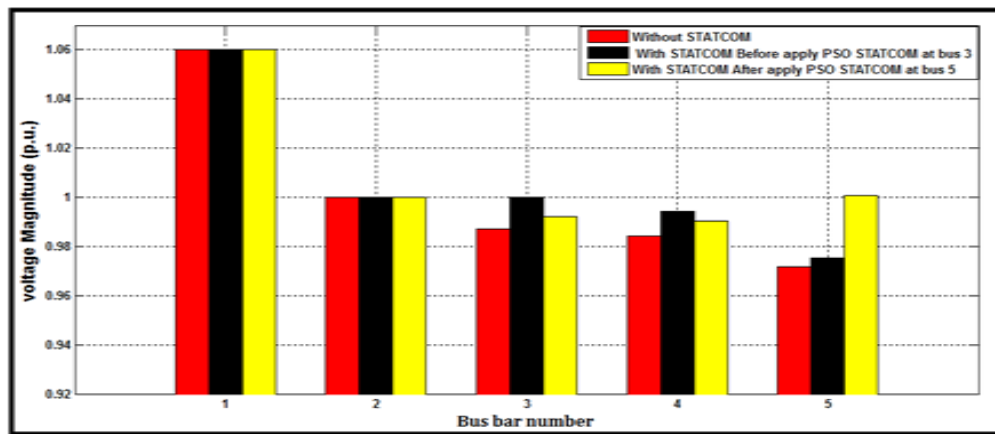

Figure 7: The bus voltage magnitudes compares with and without STATCOM for IEEE 5-bus test system

Table 2: shows the result of comparison with and without STATCOM

Without STATCOM		VD	Sloss
		0.0569	0.1595
With STATCOM [23]	(p.u)	0.0262	0.1559
	Improvement %	54%	2.25%
With STATCOM	(p.u)	0.0202	0.1188
According to Case3	Improvement %	64.5%	25.5%

II. The Iraqi National Super Grid System INSGS (400kV)

The INSGS (400kV) under study consists of 27 buses and 43 transmission lines; with total length of 4371.25 Km. Figure (8) shows the single line diagram of this network. The bus, line, and generator data are illustrated in Appendix A [20]. The total buses are divided in to 13 PV buses and 14 load buses. The load buses represent the nominated buses for installation of STATCOM devices. In the load flow solution, Musayab station (MUSP) has been selected as a slack bus, the base values for both power and voltage have been chosen to be 100 MVA and 400 kV, respectively.

Three operational cases have been chosen to be discussed in this chapter to reduce the apparent power loss and voltage-deviation.

1. Optimum Location and Parameters Settings of STATCOM-device

The proposed device is considered to implement the three cases given previously according to the objective function related to each case. The results are shown in Tables 3, 4, 5 and 6 with one, two, three and four installed STATCOM devices respectively. The effects are also explained on the apparent power losses and voltage deviation for the INSGS (400 kV).

Table 3: Result of comparison with and without STATCOM cases for INSGS ($N_{STATCOM} = 1$)

CASE	VD (p.u)	S_{Loss} (p.u)	Optimum location of STATCOM (at bus)	Optimum settings of STATCOM		Size of STATCOM (MVA)
				V_{VR} (p.u)	δ_{VR} (rad)	
Without STATCOM	0.1406	1.7712	-----	-----	-----	-----
CASE1	0.1368	1.6821	15 (BGW4)	1.1	4.2757	125.47
CASE2	0.1352	1.7402	15 (BGW4)	1.1	3.2984	26
CASE3	0.1356	1.7194	15 (BGW4)	1	3.5428	42.8

Table 4: Result of comparison with and without STATCOM cases for INSGS ($N_{STATCOM} = 2$)

CASE	VD (p.u)	S_{Loss} (p.u)	Optimum location of STATCOM (at bus)	Optimum settings of STATCOM		Size of STATCOM (MVA)
				V_{VR} (p.u)	δ_{VR} (rad)	
Without STATCOM	0.140	1.771	-----	-----	-----	-----
	6	2				

CASE1	0.136	1.583	15 (BGW4)	1.02	4.7295	147.7
	8	2	23 (BAB4)	1.06	2.1815	104
CASE2	0.128	1.742	15 (BGW4)	1.09	3.089	12
	1	7	24 (KDS4)	1.1	3.1414	13
CASE3	0.128	1.708	15 (BGW4)	0.91	3.1937	10
	9	9	24 (KDS4)	1.01	2.9319	24

Table 5: Result of comparison with and without STATCOM cases for INSGS ($N_{STATCOM} = 3$)

CASE	VD (p.u)	S_{Loss} (p.u)	Optimum location of STATCOM (at bus)	Optimum settings of STATCOM		Size of STATCOM (MVA)
				V_{VR} (p.u)	δ_{VR} (rad)	
Without STATCOM	0.1406	1.7712	-----	-----	-----	-----
CASE1	0.1315	1.5724	15 (BGW4)	1.04	4.014	92
			22 (QIM4)	1.09	5.9686	224
			23 (BAB4)	1.06	1.7801	139
CASE2	0.1271	1.7079	19(AMIN4)	1.06	1.2216	176
			15 (BGW4)	1.06	3.4904	43
			24 (KDS4)	0.98	3.1763	10
CASE3	0.1308	1.6729	15 (BGW4)	1.06	4.1885	110
			22 (QIM4)	0.97	4.3455	109
			17 (BGE4)	0.96	1.5339	133

Table 6: Result of comparison with and without STATCOM cases for INSGS ($N_{STATCOM} = 4$)

CASE	VD (p.u)	S_{loss} (p.u)	Optimum location Of STATCOM (at bus)	Optimum settings of STATCOM		Size of STATCOM (MVA)
				V_{VR} (p.u)	δ_{VR} (rad)	
Without STATCOM	0.1406	1.7712	-----	-----	-----	-----
CASE1	0.1319	1.5521	15 (BGW4)	1.05	4.5724	156.84
			18(BGN4)	1.04	6.1431	13.55
			21(KUT4)	0.94	1.082	91.56
			24(KDS4)	1.02	1.7627	155.93
CASE2	0.1242	1.6516	14(MSL4)	0.96	4.8517	121.46
			15(BGW)	0.92	4.1885	149.89
			22(QIM4)	0.97	4.363	156.17
			24(KDS4)	1.06	3.3333	215.95
CASE3	0.1265	1.6263	15(BGW)	1.09	3.0461	225
			21(KUT4)	1.06	1.5759	153.8
			22(QIM4)	0.98	4.4328	153.46
			24(KDS4)	0.9	1.0098	80.67

Table 7: Result of comparison with and without STATCOM cases for INSGS (400 kV)

NO. of STATCOM	CASE1		CASE2		CASE3		
	VD	S_{loss}	VD	S_{loss}	VD	S_{loss}	
Without STATCOM	0.1406	1.7712	-----	-----	-----	-----	
$N_{STATCOM} = 1$	(p.u)	0.1368	1.6821	0.135	1.7402	0.1356	1.7194

$N_{STATCOM} = 2$	Improvement %	2.7 %	5.03%	3.9%	1.75%	3.59%	2.92%
	(p.u)	0.1368	1.5832	0.128	1.7427	0.1289	1.709
$N_{STATCOM} = 3$	Improvement %	2.7%	10.6%	8.9%	1.61%	8.32%	3.51%
	(p.u)	0.1315	1.5724	0.127	1.7079	0.1308	1.673
$N_{STATCOM} = 4$	Improvement %	6.47%	11.2%	9.6 %	3.57%	6.95%	5.55%
	(p.u)	0.1319	1.5521	0.124	1.6516	0.1265	1.626
	Improvement %	6.22%	12.4%	11.7%	6.75%	10.1%	8.18%

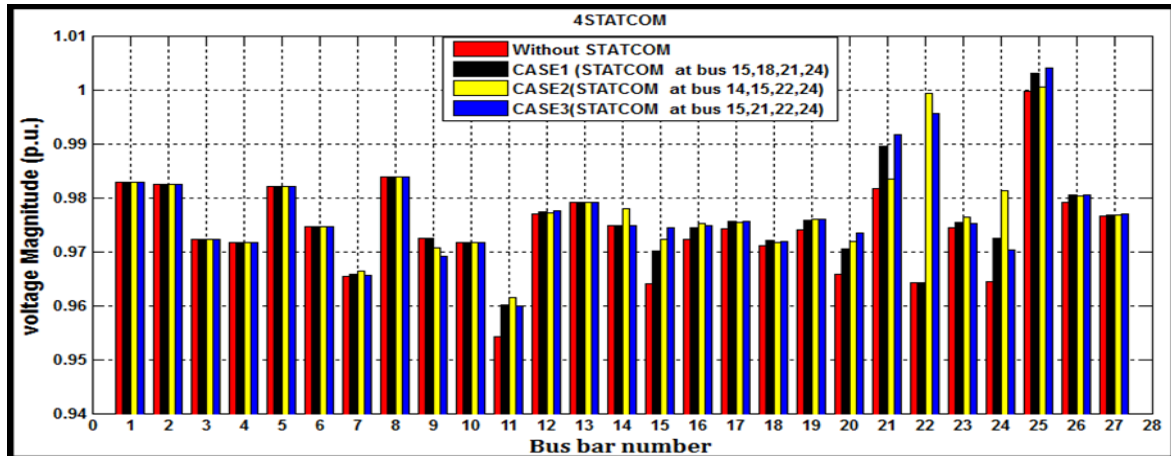

Figure 8: The bus voltage magnitudes with and without STATCOM according to $N_{STATCOM} = 4$ for Iraqi (400 kV) National super Grid System

The above tables are summarized in Table 7 for comparison among all conditions of INSGS (400 kV). Table 7 shows that any increasing in the number of the installed STATCOM devices gives a better performance for reducing the apparent power losses and voltage-deviation. From the simulation results, it is noticed the best number of the STATCOM devices is four to reduce the voltage-deviation and apparent power loss, also The bus voltage magnitudes with and without STATCOM according to $N_{STATCOM} = 4$ for INSGS (400 kV) as shown in Figure 8.

4. Conclusions

The conclusions from this work can be summarized in the following points:

- i. The results show that, the STATCOM has significant effect on improving the voltage profile and reducing apparent power losses.
- ii. The optimal location of STATCOM devices is specified for IEEE 5-bus system at bus 5, and for Iraqi (400kv) National Grid System at buses (15 BGW, 21 KUT4, 22 QIM4 and 24 KDS4) depending on the voltage deviation and apparent power loss analysis, these locations enhance the stability performance of the network when disturbances occur.

- iii. The STATCOM device performance depends on location and parameter settings of its.
- iv. Indices have been proposed to evaluate the performance and to find out the suitable location and parameters settings of the STATCOM-device in the network.

References

- [1] J. Chen, S. Song, and Z. Wang. "Analysis and Implement of Thyristor-based STATCOM in Power System Technology, 2006. PowerCon 2006. International Conference on, pp. 1-5. IEEE, 2006.
- [2] M.M. Farsangi, Y.H. Song, and Y-Z. Sun. "Supplementary Control Design of SVC and STATCOM Using H_{∞} Optimal Robust Control," In Electric Utility Deregulation and Restructuring and Power Technologies, 2000. Proceedings. DRPT 2000. International Conference on, pp. 355-360. IEEE, 2000.
- [3] R Natesan and G. Radman. "Effects of STATCOM, SSSC and UPFC on Voltage Stability," In System Theory, 2004. Proceedings of the Thirty-Sixth Southeastern Symposium on, pp. 546-550. IEEE, 2004.
- [4] A. Karami, M. Rashidinejad, and A. A. Gharaveisi. "Optimal Location of STATCOM for Voltage Security Enhancement via Artificial Intelligent," In Industrial Technology, 2006. ICIT 2006. IEEE International Conference on, pp. 2704-2708. IEEE, 2006.

- [5] Y.D. Valle, J.C. Hernandez, G.K. Venayagamoorthy, and R. G. Harley. "Optimal STATCOM sizing and placement using particle swarm optimization," In Transmission & Distribution Conference and Exposition: Latin America, 2006. TDC'06. IEEE/PES, pp. 1-6. IEEE, 2006.
- [6] P. Srithorn, M. Sumner, L. Yao, R. Parashar "A STATCOM with Supercapacitors for Enhanced Power System Stability," Power Electronics, Machines and Drives, PEMD 2008. 4th IET Conference on. IET, 2008.
- [7] F. Larki, H. M. Kelk, M. Pishvaei, A. Johar and M. Joorabian. "Optimal location of STATCOM and SVC based on contingency voltage stability by using continuation power flow: Case studies of khouzestan power networks in Iran," In Computer and Electrical Engineering, 2009. ICCEE'09. Second International Conference on, vol. 1, pp. 179-183. IEEE, 2009.
- [8] M. Karthikeyan and P. Ajay-D-Vimalraj. "Optimal location of shunt FACTS devices for power flow control," In Emerging Trends in Electrical and Computer Technology (ICETECT), 2011 International Conference on, pp. 154-159. IEEE, 2011.
- [9] P.C. Thomas, K. Sreeranjini, A.G. Pillai, V. I. Cherian, Tibin Joseph and S. Sreedharan. "Placement of STATCOM in a wind integrated power system with storage for improving the loadability of the system," In Intelligent Systems and Control (ISCO), 2013 7th International Conference on, pp. 31-35. IEEE, 2013.
- [10] R. F. Hassan and Razzaq, A. W. Abdul Razzaq, 2012 "STATCOM Application on the Iraqi (400kv) Super Grid Network with Power Oscillation Damping (POD) and Proportional Integral (PI) Controller," Engineering and Technology Journal, Vol.30, No.10, 2012.
- [11] A. Anbarasan and M.Y. Sanavullah, "Voltage Stability Improvement in Power System by Using Statcom," International Journal of Engineering Science and Technology 4 no 11. Available:https://www.idc-online.com/technical_references/pdfs/electrical_engineering/VOLTAGE%20STABILITY.pdf
- [12] A. K. Mohanty and A. K. Barik., "Power System Stability Improvement Using FACTS Devices." Inter. Jour. of Modern Eng. Research (IJMER) 1no.2: 666-672, 2011.
- [13] A.R. Krishna and C.K.R.K. Reddy, "Power Quality Problems and its improvement using FACTS devices", International Journal of Engineering Trends and Technology (IJETI), 2013.
- [14] R. Aarathi and M. V. Jayan."Grid Connected Photovoltaic System with Super Capacitor Energy Storage and STATCOM for Power System Stability Enhancement" Advances in Green Energy (ICAGE), 2014 International Conference IEEE, 2014, In Advances in Green Energy (ICAGE), 2014 International Conference on, pp. 26-32. IEEE, 2014.
- [15] B. Singh, N.K. Sharma, A.N. Tiwari, K.S. Verma, and D. Singh, "A Status review of Incorporation of FACTS Controllers in Multi-Machine Power Systems for Enhancement of Damping of Power System and Voltage Stability." International Journal of Engineering Science and Technology 2, no. 6: 1507-1525, 2010.
- [16] W. Zhang, F. Li, and L. M. Tolbert, "Review of Reactive Power Planning: Objectives, Constraints, and Algorithms." Power Systems, IEEE Transaction on 22.4: 2177-2186, 2007.
- [17] J. Zhu, "Optimiz of Power System Operation," Second edition, Vol. 47, 2015.
- [18] E. Acha, C. R. Fuerte-Esquivel, H. Ambriz-Perez and C. Angeles-Camacho, (2004), "FACTS Modelling and Simulation in Power Networks," Wiley & Sons, 2004.
- [19] S. Kansal, B.B.R. Sai, B. Tyagi, V. Kumar, "Optimal Placement of Distributed Generation in Distribution Networks." International Journal of Engineering, Science and Technology 3, no. 3, 2011.
- [20] H.A. Abdulmajeed, "Genetic Algorithm Applied to Optimal Location of Static Synchronous Compensator (STATCOM) For Iraqi National (400kV) Super High Voltage Grid", MSc. Thesis, College of Engineering, University of Baghdad, Iraq, 2014.