



Influence of Cutting Speed on Residual Stresses by Machining of AISI 316L

Safa M. Lafta^{a*}, Maan A. Tawfiq^b

^aProduction Engineering and Metallurgy Department, University of Technology Baghdad, Iraq.
safamohammed26@yahoo.com

^bProduction Engineering and Metallurgy Department, University of Technology Baghdad, Iraq.
maan.aabid@gmail.com

*Corresponding author.

Submitted: 15/07/2019

Accepted: 26/08/2019

Published: 25/03/2020

KEY WORDS

Residual stresses, cutting speed, x-ray, orthogonal cutting

ABSTRACT

RS have an important role in the performance of components and machined structures. The objective of this paper is to study the influence of cutting speed on RS in workpieces that are formed in orthogonal cutting. AISI 316L stainless steel since it has been used in many important industries such as chemical, petrochemical industries, power generation, electrical engineering, and food and beverage industry. Four cutting speeds are selected: (44, 56, 71 and 88) m/min. The alloy was machined by turning at constant depth of cut and various feed rate from (0.065 to 0.228) mm/rev. Residual stresses are examined by X-ray diffraction. The best results of RS obtained are (-3735.28, -1784.95, -330.142, -218.747, -890.758, -2999.632, -2990.401) MPa. Increasing the cutting speed from (44-56) m/min. reduces the compressive residual stress by (21.4 %), while from (71-88) m/min the RS is reduced by (19.3 %). Finally, the RS at cutting speeds are changed from compression to tension.

How to cite this article: S.M. Lafta and M.A. Tawfiq, "Influence of cutting speed on residual stresses by machining of AISI 316L" Engineering and Technology Journal, Vol. 38, Part A, No. 03, pp. 394-401, 2020.

DOI: <https://doi.org/10.30684/etj.v38i3A.459>

This is an open access article under the CC BY 4.0 license <http://creativecommons.org/licenses/by/4.0>.

1. Introduction

Residual Stresses, or internal stresses, are the stresses which remain inside a flexible body without need for external loading applied to it. These stresses are one of the most important factors that characterize surface and subsurface properties and subsequent performance of any mechanical component. They affect fatigue life, cracking growth resistance, static strength, corrosion resistance and magnetic properties. Depending on the stress, distribution specified in any component, these properties could enhance the performance of the part or weaken it [1]. RS can be tensile or compressive and can have multiple stress layers depending on cutting conditions, work materials, the geometry of cutting tool and connection conditions in both of tool and workpiece interfaces. Compressive residual stresses improve component performance and overall life time because they enhance the tensile stress in service and prevent the crack core. The tensile residual stresses tend to

increase service stresses leading to premature failure [2], as shown in Figure 1. The main effect of RS in machining is the cutting speed, when the cutting speed increases; it increases the mechanical load, thus causing the compressive residual stress on the workpiece. High speed also leads to higher temperature, thus increasing tensile residual stresses. This can lead to a critical cutting speed which surface residual stresses change from compressive to tensile [3]. At higher speeds, thermal effects predominate. This usually results in increased tensile stresses on the work surface and shallow penetration depth with increased cutting speed, because the high temperature at the cutting edge and the low time allowed for thermal diffusion leads to severe thermal gradients on the surface of the part [4]. Measuring residual stresses is not a trivial matter; so many researchers were closely interested in new or improved measurement techniques [5].

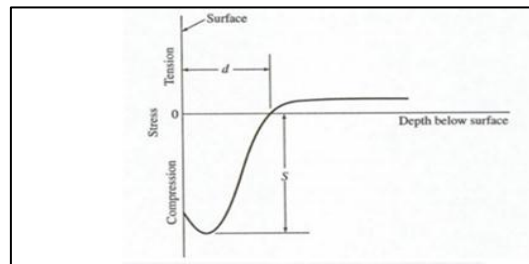

Figure 1: Example of distribute of RS along the depth below surface [2]

The measurement is based on diffraction methods, and x-ray diffraction may be the most common measure of stress. In all diffraction methods, the elastic strain of specific atomic lattice planes is measured. The X ray penetration depth in the steel is limited to about $5\mu\text{m}$ below the surface. This means that X-ray diffraction is suitable for residual stresses on the surface only [6]. Mohammadpour et al. [7] studied the influence of cutting speed on the surface, and the residual stress caused by the orthogonal cutting, AISI 1045 was selected, with the increased cutting speed, tensile residual stress was increased. Liu et al. [8] studied the effect of cutting speed on residual stress at orthogonal cutting. Titanium alloy TC4 was selected. The residual stress was compressive at low cutting and changed to the tensile stress when the cutting speed was increased. While the cutting operation was increased, the residual stress reduced to compressive again. Jacas-CabreraI et al. [9] studied the effect of cutting speed and feed rate on residual stress by using AISI 1045. The increasing in cutting speed caused little influence on the surface roughness little influence, with increasing cutting speeds from 100 to 451m /min, using feed rates in the range of 0,1to 0,2 mm / rev, the residual stress increased in the direction of traction, reflecting the direction to compression with increased of the cutting speed above 451m/min. For low feed rate (0,01 mm / rev) and any of the tested cutting speed, residual stresses were compressive. Bouacha et al. [10] used bearing steel (AISI 52100), machining process at higher cutting speeds, due to the impact of high influence of feed rate and cutting speed and little impact of depth of cut because it was remained constant, The results of the residual stresses showed that the influence of cutting speed and feed rate in both of the peripheral and axial stress behavior respectively. The measurement is based on diffraction methods, and x-ray diffraction may be the most common measure of stress. In all diffraction methods, the elastic strain of specific atomic lattice planes is measured. The X ray penetration depth in the steel is limited to about $5\mu\text{m}$ below the surface. This means that X-ray diffraction is suitable for residual stresses on the surface only [6]. Mohammadpour et al. [7] studied the influence of cutting speed on the surface, and the residual stress caused by the orthogonal cutting, AISI 1045 was selected, with the increased cutting speed, tensile residual stress was increased. Liu et al. [8] studied the effect of cutting speed on residual stress at orthogonal cutting. Titanium alloy TC4 was selected. The residual stress was compressive at low cutting and changed to the tensile stress when the cutting speed was increased. While the cutting operation was increased the residual stress reduced to compressive again. Jacas-CabreraI et al. [9] studied the effect of cutting speed and feed rate on residual stress by using AISI 1045. The increasing in cutting speed caused little influence on the surface roughness little influence, with increasing cutting speeds from 100 to 451m /min, using feed rates in the range of 0,1to 0,2 mm / rev, the residual stress increased in the direction of traction, reflecting the direction to compression with increased of the cutting speed above 451m/min. For low feed rate (0,01 mm / rev) and any of the tested cutting speed, residual stresses were compressive. Bouacha et al. [10] used bearing steel (AISI 52100), machining process at higher cutting speeds, due to the impact of high influence of feed rate

and cutting speed and little impact of depth of cut because it was remained constant, The results of the residual stresses showed that the influence of cutting speed and feed rate in both of the peripheral and axial stress behavior respectively.

2. Experimental Work

A hollow shaft of stainless steel AISI 316L of 25 mm in diameter and 60 cm in length is selected, in order to achieve orthogonal cutting conditions. Table 1, 2 and 3, show the chemical composition, mechanical properties, physical and thermal properties of stainless steel 316L respectively.

Table 1: Chemical composition of stainless steel 316L

Element	C%	Si%	Mn %	P%
Weight%	0.004	0.432	1.74	0.027
	4			1
Element%	Ni%	Cu%	Cr%	Mo%
Weight%	9.55	0.597	18.2	2.19
Element%	S%	Fe%		
Weight%	0.021	balance		
	6			

Table 2: Mechanical properties of stainless steel 316L

Property	Values and units
Yield stress (off set 0.2%)	170 MPa
Tensile stress	485 MPa
Hardness Brinell (max)	217 HB

Table 3: Physical and thermal properties of stainless steel 316L

Property	Value	Unit
Density	7.99	g/cm ³
Elastic modulus	200	GPa
Machinability	36%	-
Thermal Conductivity (con) at 100°C	16.3	(W/m.°k)
Specific electrical resistivity	0.75	Ω mm ² /m
Specific heat at 100°C	3.6	N/(mm ² °C)
	0.5	J/g. °C
	500	J/kg. °k
Melting point	1390-1440	°C
Thermal diffusivity	3.9	m ² /s

The shaft is cut into 16 specimens each one having 25mm in length, the cutting process is done using Wire EDM technique, Figure 2 shows the specimen dimensions of the specimen after cut and before machining.

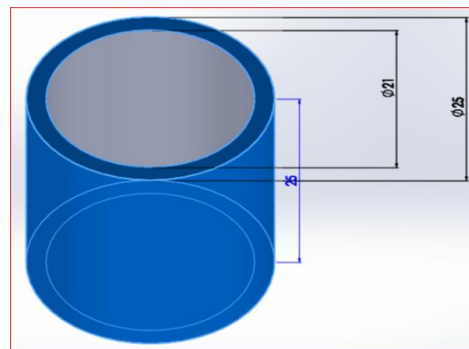

Figure 2: Specimen dimensions before machining

The cutting conditions are selected as $V_c = (44\text{m/min}, 56\text{m/min}, 71\text{m/min}, 88\text{m/min})$ at constant depth of cut, const. feed rate = 0.228 mm/rev. Table 4 shows the machining conditions. Universal turning machine type sinus 330\3000(SN-126130), is shown in Figure 3 was used to perform the experimental work. It has the following technical specifications being shown in Table 5. One type of cutting tool is used in this study. The insert used is coated carbide (PVD with TNMG) and it is selected as negative turning inserts according to specifications that are show in Table 6.

Table 4: Machining conditions of experiments

Rotational cutting speed r.p.m	Cutting speed V_c m/min
1120	88
900	71
710	65
950	44



Figure 3: Universal turning machine model 330\3000 being used in experimental work

Table 5: Lathe technical specifications.

Specification	Description
Type and model	Universal center lathe sinus (330/3000)
Center width	3000 mm
Overall dimensions	4707×1230×1595 mm
Total power of machine	7.84 Kw
Spindle speed	9 - 1600 r.p.m
Feed rate	0.028 - 6.43 mm/rev.

Table 6: Tungsten carbide inserts TNMG

Type	TNMG
Material	100% raw new material of tungsten carbide
Chip breaker	DM- mainly recommended for semi finishing steel
ISO grade	P\M
Coating	CVD
Standard	ISO international standard

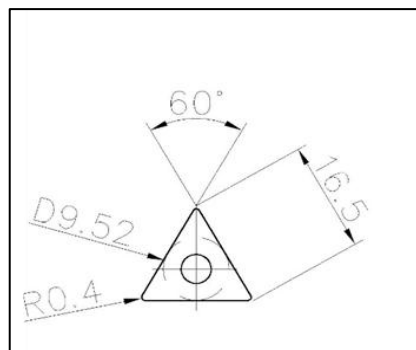

Figure 4: Dimensions of the cutting insert tool in mm

A tool holder type STACR\L 90 Deg. Screw clamp turning tool holder with dimensions as shown in Figure 5.

The residual stresses were examined by x-ray device (XRD-6000), Table 7 shows the specifications of the device.

The device is shown in Figure 6.

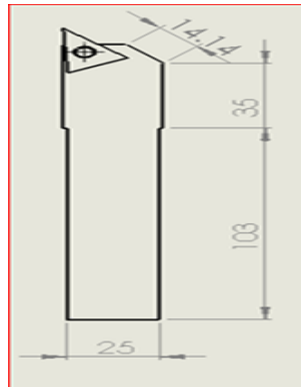

Figure 5: Tool holder STACR\L 90 Deg. Screw clamp

Table 7: Specifications of the device

Name of the device:	ORIONRKS 6000
Serial number of the device:	1811020
Device manufacture:	ORION
Model:	RKS 1500F-V-SP



Figure 6: X-ray diffraction device of residual stresses measuring

3. Results and Discussion

Results obtained from X-ray diffraction: Table 8 show the results of residual stresses when feed rate was (0.228) mm/rev and Figure 7 show the values of residual stresses when feed rate was (0.228) mm/rev.

Table 9 shows the results of residual stresses when feed rate was (0.16) mm/rev and Figure 8 shows the values of residual stresses when feed rate was (0.16) mm/rev.

Table 10 shows the results of residual stresses when feed rate was (0.08) mm/rev and Figure 9 shows the values of residual stresses when feed rate was (0.08) mm/rev.

Table 8: Results of residual stresses obtained at (0.228) mm/rev

Feed rate mm/rev	Cutting speed m/min	Residual stresses MPa
0.228	44	-3735.28
0.228	56	-1784.95
0.228	71	-330.142
0.228	88	573.656

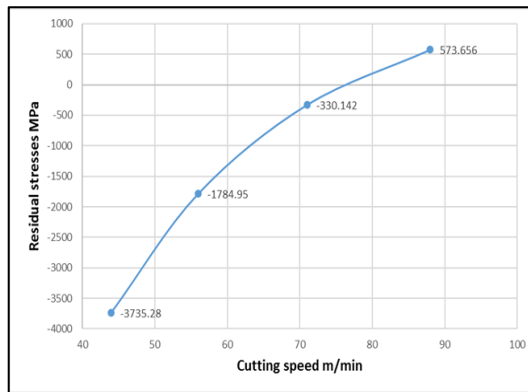

Figure 7: Values of residual stresses and cutting speeds at (0.228 mm/rev) feed rate

Table 9: Results of residual stresses obtained at (0.16) mm/rev

Feed rate mm/rev	Cutting speed m/min	Residual stresses MPa
0.16	44	-218.747
0.16	56	-890.758
0.16	71	1908.766
0.16	88	1398.648

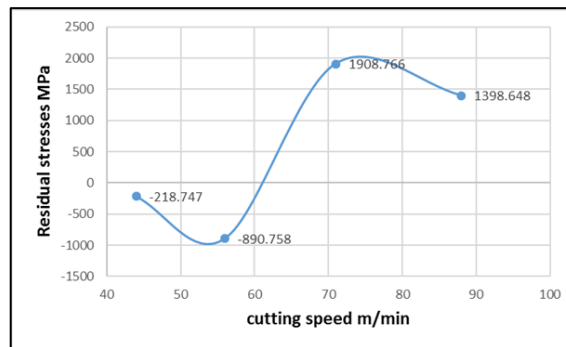

Figure 8: Values of residual stresses and cutting speeds at (0.16 mm/rev) feed rate

Table 10: Results of residual stresses obtained at (0.08) mm/rev

Feed rate mm/rev	Cutting speed m/min	Residual stresses MPa
0.08	44	-2999.632
0.08	56	-5041.018
0.08	71	3117.652
0.08	88	4749.075

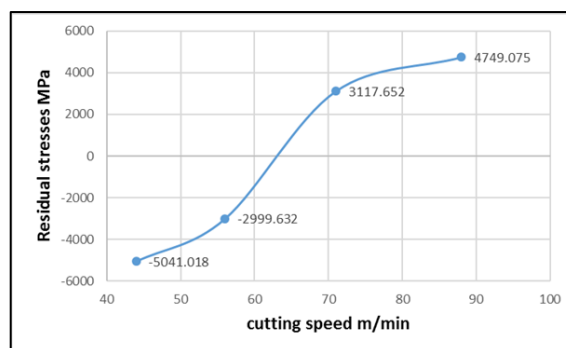

Figure 9: Values of residual stresses and cutting speeds at (0.08 mm/rev) feed rate

Table 11 shows the results of residual stresses when feed rate was (0.065) mm/rev and Figure 10 shows the values of residual stresses when feed rate was (0.065) mm/rev.

The depth of cut was constant in each specimen and it was equal to 2 mm while cutting speeds were varied. The results in curves above show that the residual stresses started with compressive residual

stresses because the cutting speed was low and then changed to tensile residual stresses with increasing the cutting speed gradually. At low cutting speed, the cutting force decreases and that the main reason to make the residual stresses in tension state, and that depending on Jomaa et al. [11] studied the effect of cutting parameters on the RS, and the results showed that Surface residual stress was tensile when the cutting speed was increased. Min wan et al. [12] studied the effect of different cutting parameters such as (cutting speed and feed rate), The results showed that when reduced in cutting speed and increased in feed rate, led to increase of compressive residual stresses on surfaces.

Table 11: Results of residual stresses obtained at (0.065) mm/rev

Feed rate mm/rev	Cutting speed m/min	Residual stresses MPa
0.065	44	-1150.171
0.065	56	-2990.401
0.065	71	866.15
0.065	88	1018.73

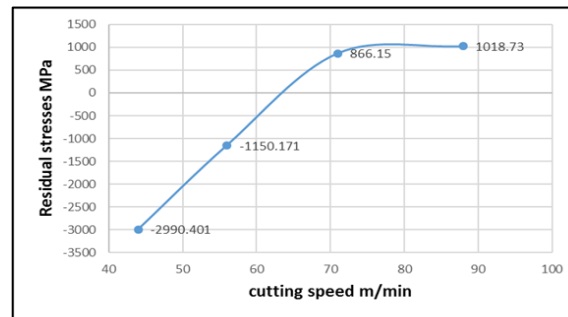

Figure 10: Values of residual stresses and cutting speeds at (0.065 mm/rev) feed rate

4. Conclusions

Tensile residual stresses generated by increasing of cutting speed, because it reduces the corresponding cutting forces and increasing in cutting speed leads to reduce the friction between the insert and the workpiece therefore the machining surfaces in high cutting speed be softer than surfaces machining in small cutting speed. The best results of RS obtained are (-3735.28, -1784.95, -330.142, -218.747, -890.758, -2999.632, -2990.401) MPa. Increasing the cutting speed from (44-56) m/min. reduces the compressive residual stress by (21.4 %), while from (71-88) m/min the RS is reduced by (19.3 %). At cutting speeds which were selected, the results of Rs were changed from compression to tension. Residual stresses remained unchanged with the changing cutting speeds. This can be attributed to the minimal effect of cutting velocity on cutting force in the selected range.

References

- [1] E. Brinksmeier, J. Cammett, W. Koenig, P. Leskovar, P. Peters and H. Toenshoff, "Residual stresses - measurement and causes in machining processes," *Ann. CIRP*, vol. 31, No. 2, pp. 491-510, 1982.
- [2] C. Maranhão and J. P. Davim, "Residual stresses in machining using FEM 7 5 2 PA Review," *Rev. Adv. Mater. Sci.*, Vol. 30, pp. 267-272, 2012.
- [3] M. Jacobson, P. Dahlman and F. Gunnberg, "Cutting speed influence on surface integrity of hard turned bainite steel," *J. of Materials Processing Technology*, vol. 128, no. 1, pp. 318-323, 2002.
- [4] R. M. Saoubi, J. Outeiro, B. Changeux, J. Lebrun and A. Dias, "Residual stress analysis in orthogonal machining of standard and desulfurized AISI 316L steels," *J. of Materials Processing Technology*, Vol. 96, No. 1, pp. 225-233, 1999.
- [5] I. S. Jawahir, E. Brinksmeier, R. M. Saoubi, D. Aspinwal, J. Outeiro, D. Meyer, D. Umbrello and A. Jayal, "Surface integrity in material removal processes: recent advances," *Ann. CIRP*, vol. 60, no. 2, pp. 603-626, 2011.
- [6] P. Withers, M. Turski, L. Edwards, P. Bouchard and D. Buttle, "Recent advances in residual stress measurement," *Int. J. of Pressure Vessels and Piping*, vol. 85, no. 3, pp. 118-127, 2008.

- [7] M. Mohammadpour, M. R. Razfar, R. Jalili Saffar, "Numerical investigating the effect of machining parameters on residual stresses in orthogonal cutting," *Simulat. Modell. Pract. Theory*, Vol. 18, pp. 378-389, 2010.
- [8] Ch. Liu, A. Zengqiang Wang, "The effect of cutting speed on residual stresses when orthogonal cutting TC4," *11th International Conference on the Mechanical and Physical Behavior of Materials under Dynamic Loading, held in Lugano, Switzerland, Edited by E. Cadoni; EPJ Web of Conferences*, Vol. 94, No. 4, 2015.
- [9] M. Jacas-Cabrera and T. Rodríguez-Moliner, "The influence of cutting speed and feed rate in surface integrity of AISI 1045," *Ingeniería Mecánica*. Vol. 18. No. 3, pp. 203-210, 2015.
- [10] Kh. Bouacha and M. A. Yallese, "Statistical analysis of surface roughness and cutting forces using response surface methodology in hard turning of AISI 52100 Bearing Steel with CBN tool," *Int. Journal of Refractory Metals & Hard Materials*, Vol. 28, pp. 349–361, 2010.
- [11] W. Jomaa, V. Songmene, and P. Bocher. "On residual stress changes after orthogonal machining of induction hardened AISI 4340 steel," *Proceedings of Materials Science and Technology Conference and Exhibition, MS and T*, Vol. 13, pp. 94-103, 2013.
- [12] M. Wan, Xiangyue, D. Wen, W. Zhang "Modeling of machining induced residual stresses," *J Mater Sci*, Vol. 54, pp, 1-35, 2019.