



Characteristics of Exhaust Emissions for a Diesel Engine Fuelled by Corn Oil Biodiesel and Blended with Diesel Fuel

Abdulrahman S. Mahmood^{a*}, Haqi I. Qatta^b, Saadi M.D. Al-Nuzal^c, Talib K. Abed^d

^a Environmental Research Center, University of Technology, Baghdad, Iraq. 50208@uotechnology.edu.iq

^b Nanotechnology and Advanced Materials Research Center, University of Technology, Baghdad, Iraq. 50077@uotechnology.edu.iq

^c Environmental Research Center, University of Technology, Baghdad, Iraq.

^d Environmental Research Center, University of Technology, Baghdad, Iraq. 10946@uotechnology.edu.iq

*Corresponding author.

Submitted: 06/07/2019

Accepted: 11/09/2019

Published: 25/03/2020

KEY WORDS

Environmentally friend biodiesel fuel; Diesel engine; Corn oil, Emission gases; Fuel Blend.

ABSTRACT

Environmentally friend biodiesel fuel from corn oil was tested in single-cylinder 4-stroke diesel engine operated. Three blends of fuels were prepared from corn oil and diesel fuel viz. 7, 15, and 20 % (designated as B7, B15, and B20, respectively). Tests were conducted on this engine using these blends at a constant speed (1500 rpm) and varying loads (0 % to 100 %). The emissions of carbon monoxide, carbon dioxide, unburned hydrocarbons, nitrogen oxides (NO_x) and smoke opacity were measured. In all engine loads, results showed that the emission of CO, HC, and smoke emissions were reduced, while that of NO_x and CO₂ were increased. Biodiesel blend (B20) showed the highest decrease of the CO and HC and smoke emissions by 22.13 %, 18.5 %, and 25.8 % respectively. While that of NO_x and CO₂ emissions were increased by 22.3 % and 22%, respectively. It can be recommended as a sound environment friend and renewable for use in diesel engines and can be used without any significant modifications in the engine design.

How to cite this article: A. S. Mahmood, H. I. Qatta, S. M. D Al-Nuzal and T. K. A.Abed, "Characteristics of exhaust emissions for a diesel engine fuelled by corn oil biodiesel and blended with diesel fuel," Engineering and Technology Journal, Vol. 38, Part A, No. 03, pp. 457-464, 2020.

DOI: <https://doi.org/10.30684/etj.v38i3A.446>

1. Introduction

The diesel engine as an internal combustion engine finds wide application in many sectors such as transport, industry, and agriculture, because of its higher efficiency, fuel consumption and greater capacity [1]. Unfortunately, their main drawback was the emissions of carbon monoxide, nitrogen oxides, and smoke, which are the main air pollution, which affects human health and the environment

[2-3]. The global expanding industrial use of diesel-powered vehicles led to an increased demand for fossil fuels continuously. The consequence leads to the future depletion of fossil fuels, for it is not non-renewable [4]. Therefore, there must be a search for an alternative [5-6]. The Use of biodiesel will be the best alternative to operate internal combustion engines for many reasons; it is a renewable, environment-friendly product, and can be used without any significant modifications to engine design [7-8]. Unfortunately, biodiesel is produced from vegetable oils or animal fats, and cannot be used directly as a fuel [9]. Usually, it possesses high viscosity, and, consequently, causes some problems in handling like incomplete combustion, blockage of fuel filter and poor atomization [10]. However, several solutions can be used to overcome its high viscosity such as blending, micro emulsion, pyrolysis, and transesterification [11]. Thus, the use of biodiesel and its blends with diesel fuel was found to reduce the emissions of CO, SO₂, HC, and PM [12-15]. Waste cooking oil biodiesel at various proportions of 10 %, 20 % and 30 % and its blends with diesel fuel at the different engine loads [16]. It was found that these blends reduce the CO, HC and smoke emissions. Cotton seed and ethanol (10 - 50 %) thermal efficiency were found similar to that of diesel fuel, and on loads increasing there was a decrease in NO_x, Smoke, CO and HC emissions [17]. Rice bran biodiesel blends, at a compression ratio 14, showed that many blends can be used as a fuel without any modifications to engine [18]. De Serio, et al. conducted experiments on direct injection diesel engine with exhaust gas recirculation (EGR) system and examine the emissions. They found that on using 7.5 % of unspecified biodiesel blend, it reduce NO_x emissions by 30 %, while a slight increase in CO, CO₂ and HC emissions [19]. The performance of blends of waste sunflower oil in diesel fuel in compression ignition engine at different speeds and loads was examined and found reduce the emissions by 20-35 % for CO and HC.

The objective of this work is to study the effect of using cheap corn oil biodiesel available in the Iraqi markets and its blends with diesel fuel on the emission characteristics of single-cylinder, 4-stroke diesel engine. The tests were conducted on the engine at a constant speed (1500 rpm), and varying loads (0 % to 100 %). The emission results for the biodiesel blends were discussed and compared with pure diesel fuel [20-21].

2. Materials and Methodology

I. Preparation of biodiesel

Corn oil was used as biodiesel at different volume ratios and its blends with pure diesel fuel to run the diesel engine. It was produced through the transesterification process with the methanol (CH₃OH), to reduce its viscosity. The fuel blends were prepared by blending the corn oil biodiesel with volume proportions of 7 %, 15 % and 20 % in diesel fuel, and designated B7 and B15, B20, respectively. The blending process was performed using a mechanical mixer at 300 rpm, with stirring the mixture at a temperature of 60 °C for 50 - 60 minutes using a mechanical mixer (IKA Eurostar 40 Digital Overhead Stirrer, Germany). The properties of the fuel used in this study were determined using three measuring devices are: hydrometer to measure the density. The viscosity of fuel blends was measured by using rotational viscometer type-VR3000 Supplied by MYR, TQC Sheen B.V., and Netherlands. The Calorific Value was determined by using Microprocessor Bomb Calorimeter, Automatic System CC01/M3 Supplied by Toshniwal Technologies Pvt. Limited, India. Table-1 shows the properties of biodiesel from corn oil blends in diesel fuel B7, B15 and B20, and pure diesel fuel.

II. Experimental setup

The experimental work was performed by using a single-cylinder, 4-stroke diesel engine equipped with emission sensors to evaluate the various emissions (CO, CO₂, HC, NO_x, and smoke). Table 2 shows the specifications of the engine used in this study. Figure-1 shows a photograph of the test engine, which consists of a single-cylinder, 4-stroke direct injection diesel engine, cooled by water and a rope brake dynamometer to apply different loads to the engine, as well as a schematic diagram of the experimental setup, which was shown in Figure 2. Thermocouples of type (k) were used to measure the exhaust temperatures. The exhaust emissions of carbon monoxide (CO), unburned hydrocarbons (HC), nitrogen oxides (NO_x) and carbon dioxide (CO₂) were measured using AVL DiGAS 444 exhaust gas analyzer, and for smoke opacity, the smoke meter device of type (AVL 437C) was used, both supplied by Avl India Private Limited, India.

Table 1: Properties of pure diesel fuel and corn oil Biodiesel blends

Property	Diesel Fuel	B7	B15	B20
Density at 20 °C (kg/m ³)	830	835.2	839.4	842
Kinematic Velocity at 40 °C (cst)	2.67	2.85	2.97	3.02
Calorific Value (kJ/kg)	42920	42135	41760	41180

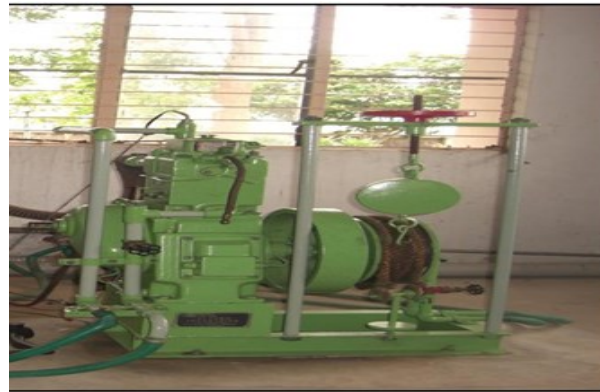
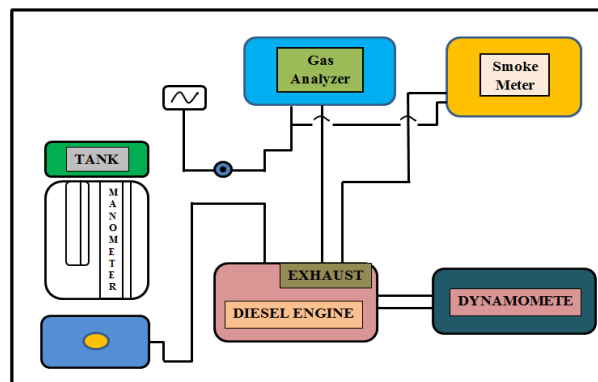
**Figure 1: A photograph of the test diesel engine.****Figure 2: Schematic diagram of the experimental setup****Table 2: Engine specifications**

Engine Make	Kirloskar
Engine Type	Single Cylinder, 4-Stroke, Diesel Engine
Injection System	Direct Injection
Cooling type	Water Cooled
Bore	80 mm
Stroke	110 mm
Rated Power	3.7 K W (5 HP)
Engine Speed	1500 rpm
Compression Ratio	17:1
Dynamometer	rope brake dynamometer

III. Experimental procedure

A series of experiments were carried out on the diesel engine using pure diesel fuel and biodiesel blends from corn oil at volume proportions of B7, B15, and B20 in diesel fuel, which was prepared before the test. Before starting the experiments on the engine, it must be assured that the probes of

exhaust gas analyzer and smoke opacity meter are inserted into the exhaust pipe to measure the emissions. The engine was run using pure diesel fuel at a constant speed (1500 rpm), for 15-20 minutes to warm-up, then the engine is loaded with different loads (0 %, 25 %, 50 %, 75 % and 100 % load) by a rope brake dynamometer. When the engine reaches the steady-state for each load state, the emission values of CO, HC, NO_x and CO₂ are recorded by the exhaust gas analyzer device, and recording the smoke opacity values by the smoke meter device and for every 10 ml of fuel consumption. The test was repeated three times for each load condition to obtain the average of optimum values for the exhaust emissions. After recording the emission values, the engine is stopped and discharged from residual pure diesel. Then, the engine is run again three times using biodiesel blends of corn oil B7, B15, and B20 respectively, the emissions were recorded under similar operating conditions to that of pure diesel fuel in terms of engine speed and loading and the data were presented in Figures 3 -7.

3. Results and Discussion

The emission of CO obtained from corn oil biodiesel blends B7, B15, B20 and base diesel fuel versus engine load at a constant speed (1500 rpm) and different loads (0 - 100 %) were tested and presented in Figure-3. The incomplete combustion process of fuel inside the cylinder is responsible for the formation of CO emissions, which decreased on using higher engine loads. Increasing engine load will increase the temperature inside the cylinder, and consequently will help to enhance the complete combustion of the fuel. Figure 3 reveals that CO emissions were declined on adding corn oil. The reason behind this decline is the presence of enough oxygen content to improve the combustion process. The CO emissions of biodiesel blends decreased by 7%, 14.6%, and 22.13% respectively, compared to that of pure diesel fuel.

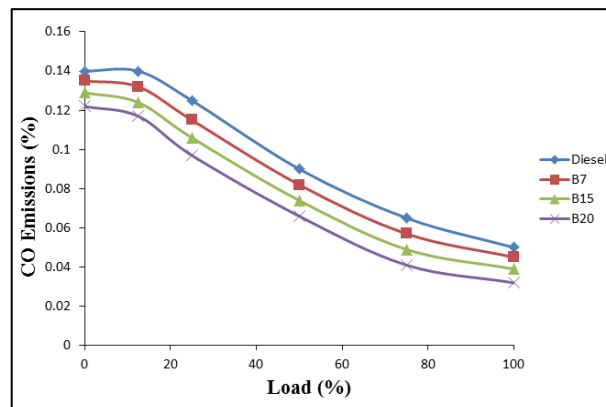

Figure 3: The CO emissions of biodiesel B7, B15, B20 and pure diesel fuel versus engine varying loads

The HC emission behaves similarly to that of CO, as shown in Figure 4. The reason behind the production of HC emissions is the insufficient combustion temperature to burn the fuel completely inside the cylinder, thus the unburned fuel will escape to the exhaust without doing work, and increasing engine load will improve the combustion process. Figure-4 reveals that the HC emission decreases when the proportion of corn oil biodiesel in diesel fuel increases. The presence of oxygen in corn oil improves combustion efficiency and thereby reduces HC emissions [22-23]. The results showed that the HC emissions of corn oil biodiesel blend B7, B15 and B20 were less by 6.8%, 12.7%, and 18.5% respectively, compared with pure diesel fuel.

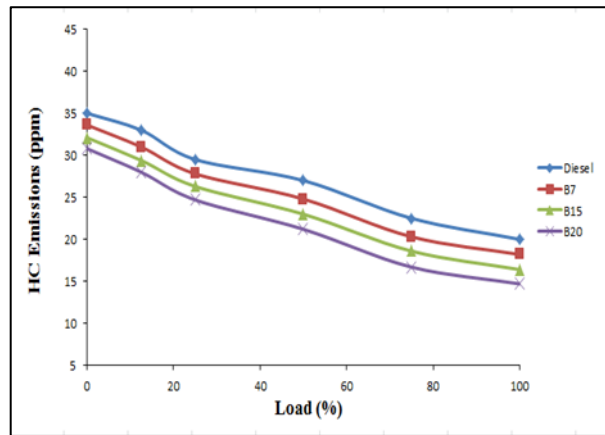

Figure 4: The HC emissions of biodiesel B7, B15, B20 and pure diesel fuel versus engine varying loads

The smoke opacity for the blends of corn oil biodiesel and pure diesel fuel versus load was shown in Figure-5. It is formed as a result of incomplete combustion of fuel inside the cylinder and can be related to the following: the lack of air amount entering to the cylinder; the increase of the amount of injected fuel into the combustion chamber; and the low oxygen content of the fuel [24]. From the figure, it is apparent, that an increase in the smoke opacity on increasing the engine loads was observed for all the types of fuel used. This is due to the increase of fuel amount entering the cylinder when the load increased, and that the excess fuel inside the cylinder leads to partial combustion of fuel, thus increasing the smoke opacity. It was found that using biodiesel blend from corn oil in diesel fuel produces less smoke opacity compared with pure diesel fuel. This is a result of the presence of high oxygen content in biodiesel, which in turn helps to achieve better combustion of fuel and thus reduces the smoke opacity. Smoke opacity decreased by 9.2 %, 18.3 % and 25.8 % for biodiesel blend B7, B15, and B20 respectively, compared to the pure diesel fuel.

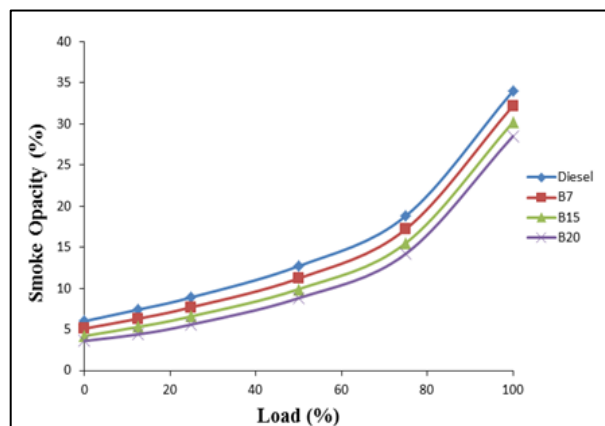

Figure 5: The smoke opacity of biodiesel B7, B15, B20 and pure diesel fuel versus engine varying loads

Figure 6 showed the relation of NO_x emissions of corn oil biodiesel blends and pure diesel versus loads. Several reasons are leading to increasing the formation of NO_x emissions in diesel engines are the high flame temperatures associated with the peak cylinder temperature, the presence of oxygen inside the combustion chamber, reduce the ignition delay and increase the amount of fuel entering the cylinder [16, 25]. Through the figure, it was observed that the increase of NO_x emissions for all the used fuel on increasing the engine loads is a result of the increase in the amount of the burned fuel inside the combustion chamber, as well as increasing the cylinder temperature. Also, there was an increase in NO_x emissions on increasing the percentage of corn oil biodiesel for all engine loads compared to the pure diesel fuel. This is due to the high oxygen content in biodiesel, which will increase the combustion temperature, and consequently increases the NO_x emissions. It was found that the NO_x emissions for biodiesel B7, B15 and B20 increased by 5.6 %, 14.8 %, and 23.2 %, respectively, compared to pure diesel fuel.

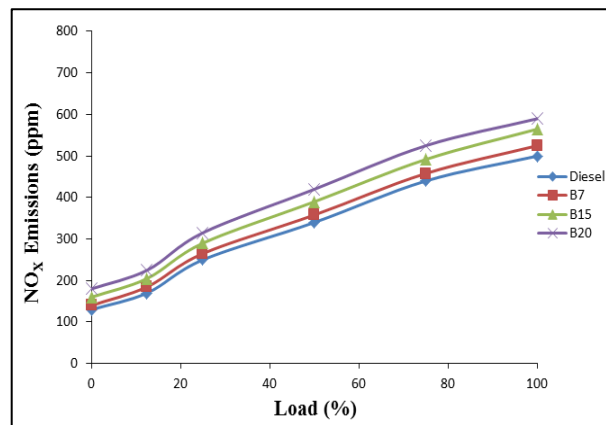

Figure 6: The NO_x emissions of biodiesel B7, B15, B20 and pure diesel fuel versus engine varying loads

Figure 7 shows the variation of CO₂ emissions for corn oil biodiesel blends B7, B15, B20 and pure diesel fuel versus loads. Diesel engines have better combustion efficiency, so the CO₂ emissions in diesel engines are produced due to the complete combustion of fuel inside the combustion chamber. From the figure, it can be observed that on increasing the engine loads, CO₂ emissions increase for all types of fuels used. This increase is related to the increase in the peak cylinder temperature, which leads to improving the combustion process and thus the CO₂ emissions increase. In addition, it was found that on increasing the percentage of corn oil biodiesel, CO₂ emissions increases and were higher than those in pure diesel fuel. This increase can be explained that the use of biodiesel blends has significantly improved the combustion process, thus the complete combustion of fuel inside cylinder increases the CO₂ emissions. Moreover, biodiesel has higher carbon content than pure diesel fuel, and this will increase CO₂ emissions. The CO₂ emissions increased by 6.6 %, 15 % and 22 % for biodiesel blend B7, B15, and B20 respectively, compared to the pure diesel fuel.

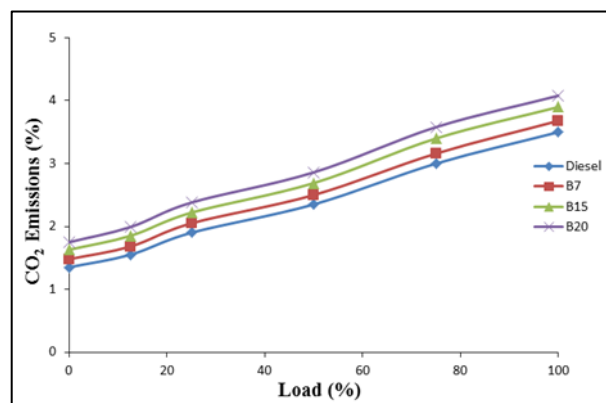

Figure 7: The CO₂ emissions of biodiesel B7, B15, B20 and pure diesel fuel versus engine varying loads.

4. Conclusions

The single-cylinder diesel engine was run using biodiesel blends B7, B15, B20, and pure diesel fuel. The amount of CO, CO₂, HC, NO_x, and Smoke emissions were measured at the varying engine loads for the biodiesel blends, compared to that of pure diesel fuel. The following conclusions can be withdrawn from the above discussion:

1. Corn oil biodiesel blends (B7, B15, and B20) can be used as an alternative, to run the internal combustion engines without any modifications.
2. Its use led to the reduction of CO, HC, and Smoke emissions, at the same time it increases NO_x and CO₂ emissions compared to pure diesel fuel.
3. Increasing the percentage of corn oil in fuel blends, the ratio of CO, HC and Smoke emissions decreases and the ratio of NO_x and CO₂ emissions increases.
4. Biodiesel blend (B20) showed the highest decrease of the CO, HC and smoke emissions by 22.13 %, 18.5 %, and 25.8 % respectively, while it showed the highest increase the NO_x and CO₂ emissions by 22.3% and 22%, respectively, compared with pure diesel fuel.

5. Corn oil biodiesel blend B20 in pure diesel fuel can be recommended as the best percentage for use in the diesel engine.

References

- [1] M. R. Seifi, S. R. Hassan-Beygi, B. Ghobadian, U. Desideri, and M. Antonelli, "Experimental investigation of a diesel engine power, torque and noise emission using water–diesel emulsions," *Fuel*, Vol. 166, pp.392-399, 2016.
- [2] A. Sharma, N. Kumar, V. Vibhanshu, and A. Deep, "Emission studies on a VCR engine using stable diesel water emulsion," *SAE Technical Paper*; SAE International: Warren dale, WA, USA, (No. 2013-01-266, 2013.
- [3] I. A. Resitoglu, K. Altinişik, and A. Keskin, "The pollutant emissions from diesel-engine vehicles and exhaust after treatment systems," *Clean Technologies and Environmental Policy*, Vol. 17, No. 1, pp. 15-27, 2015.
- [4] F. Martins, C. Felgueiras, M. Smitkova, and N. Caetano, "Analysis of fossil fuel energy consumption and environmental impacts in European countries," *Energies*, Vol. 12, No. 6, pp. 964, 2019.
- [5] A. Mahalingam, D. B. Munuswamy, Y. Devarajan, and S. Radhakrishnan, "Emission and performance analysis on the effect of exhaust gas recirculation in alcohol-biodiesel aspirated research diesel engine," *Environmental Science and Pollution Research*, Vol. 25, No. 13, pp. 12641–12647, 2018.
- [6] M. Singh, S. K. Gandhi, S. K. Mahla, and S. S. Sandhu, "Experimental investigations on performance and emission characteristics of variable speed multi-cylinder compression ignition engine using diesel/ argemone biodiesel blends," *Energy Exploration and Exploitation*, Vol. 36, No. 3, pp. 535-555, 2018.
- [7] S. Dharma, H. H. Masjuki, H. C. Ong, H. C., Sebayang, A. H., Silitonga, A. S., Kusumo, F., and T. M. I. Mahlia, "Optimization of biodiesel production process for mixed jatropha curcas – ceiba pentandra biodiesel using response surface methodology," *Energy Conversion and Management*, Vol. 115, pp. 178-190, 2016.
- [8] C. M. Noor, M. M. Noor, and R. Mamat, "Biodiesel as alternative fuel for marine diesel engine applications: a review," *renewable and sustainable energy reviews*, Vol. 94, pp. 127-142, 2018.
- [9] E. Alptekin, M. Canakci, and H. Sanli, "Biodiesel production from vegetable oil and waste animal fats in a pilot plant," *Waste Management*, Vol. 34, No. 11, pp. 2146-2154, 2014.
- [10] H. K. Imdadul, H. H. Masjuki, Kalam, Zulkifli, N. W.M., Rashed, M. M., Rashedul, H. K., Monirul, I.M. and M. H. Mosarof, "A Comprehensive review on the assessment of fuel additive effects on combustion behavior in ci engine fuelled with diesel biodiesel blends," *RSC Advances*, Vol. 5, No. 83, pp. 67541-67567, 2015.
- [11] S. Grebemariam, and J. M. Marchetti, "Biodiesel production technologies," *AIMS Energy*, Vol. 5, No. 3, pp. 425-457, 2017.
- [12] Udayakumar, R., and Khurana, S., "Experimental investigations on emissions characteristics of a variable compression ratio engine operated on dual fuel mode using diesel and biodiesel (obtained from cotton seed oil and rice bran oil)," *Journal of Mechanical Engineering Research and Developments (JMERC)*, Vol. 41, No. 3, pp. 59-66, 2018.
- [13] O. M. Ali, R. Mamat, N. R. Abdullah, and A. A. Abdullah, "Analysis of blended fuel properties and engine performance with palm biodiesel–diesel blended fuel," *Renewable Energy*, Vol. 86, pp. 59-67, 2016.
- [14] L. A. Raman, B. Deepanraj, S. Rajakumar, and V. Sivasubramanian, "Experimental investigation on performance, combustion and emission analysis of a direct injection diesel engine fuelled with rapeseed oil biodiesel," *Fuel*, Vol. 246, pp. 69-74, 2019.
- [15] M. S. Gad, R. El-Araby, K. A. Abed, N. N. El-Ibiari, A. K. El Morsi, and G. I. El-Diwani, "Performance and emissions characteristics of CI engine fueled with palm oil/palm oil methyl ester blended with diesel fuel," *Egyptian Journal of Petroleum*, Vol. 27, No. 2, pp. 215-219, 2018.
- [16] K. A. Abed, A. K. El Morsi, M. M. Sayed, A. A. El Shaib, and M. S. Gad, "Effect of waste cooking-oil biodiesel on performance and exhaust emissions of a diesel engine," *Egyptian Journal of Petroleum*, Vol. 27, No. 4, pp. 985-989, 2018.
- [17] B. Prbakaran, D. and Viswanathan, "Experimental investigation of effects of addition of ethanol to biodiesel on performance, combustion and emission characteristics in CI engine," *Alexandria Engineering Journal*, Vol. 57, No. 1, pp. 383-389, 2018.
- [18] M. Chhabra, A. Sharma, and G. Dwivedi, "Performance evaluation of diesel engine using rice bran biodiesel," *Egyptian Journal of Petroleum*, Vol. 26, No. 2, pp. 511-518, 2017.

- [19] D. De Serio, A. de Oliveira, and J. R. Sodré, "Effects of EGR rate on performance and emissions of a diesel power generator fueled by B7," *Journal of the Brazilian Society of Mechanical Sciences and Engineering*, Vol. 39, No. 6, pp. 1919-1927, 2017.
- [20] M. S. Imran, and H. J. Kurji, "The impact of using biodiesel prepared from waste sunflower oil and iraqi conventional diesel on compression ignition engine performance and emissions," *Journal of Mechanical Engineering Research and Developments (JMERE)*, Vol. 41, No. 3, pp. 32-37, 2018.
- [21] P. Dinesha, and P. Mohanan, "A study of the effect of injection mressure on the combustion, performance, and emission characteristics of cardanol biofuel blend fuelled compression ignition Engine," *Asia-Pacific Journal of Chemical Engineering*, Vol. 10, No. 1, pp. 56-64, 2015.
- [22] S. S. Satputaley, D. B. Zodpe, and N. V. Deshpande, "Performance, combustion, and emission study on CI engine using microalgae oil and microalgae oil methyl esters," *Journal of the Energy Institute*, Vol. 90, No. 4, pp. 513-521, 2017.
- [23] A. Killol, N. Reddy, S. Paruvada, and S. Murugan, "Experimental studies of a diesel engine run on biodiesel n-butanol blends," *Renewable Energy*, Vol. 135, pp. 687-700, 2019.
- [24] M. K. Yesilyurt, "The effects of the fuel injection pressure on the performance and emission characteristics of a diesel engine fuelled with waste cooking oil biodiesel-diesel blends," *Renewable energy*, Vol. 132, pp. 649-666, 2019.
- [25] M. Yadav, S. B. Chavan, R. Singh, F. Bux, and Y. C. Sharma, "Experimental study on emissions of algal biodiesel and its blends on a diesel engine," *Journal of the Taiwan Institute of Chemical Engineers*, Vol. 96, pp.160-168, 2019.