

**Faris H. AL Ani** Civil Engineering  
Department, University of  
Technology, Baghdad, Iraq**Ghayda Y. AL-Kindi**Civil Engineering  
Department, University of  
Technology, Baghdad, Iraq**Noor Kh. Al-Bidri**Civil Engineering  
Department, University of  
Technology, Baghdad, Iraq

Received on: 24/09/2018

Accepted on: 10/01/2019

Published online: 25/05/2019

## Diclofenac Removal from Wastewater by Iraqi Pillared Clay

**Abstract-** This study deals with the removal of Pharmaceutical pollutants such as Diclofenac, which caused hazardous pollutant for human health, from aqueous solution. The aim of this study is an investigation to remove the diclofenac from synthesis wastewater by using of pillared clay that made from Iraqi clay (AL-Anbar clay) as adsorbent by using both batch and packed bed reactor to study kinetic model. The experimental work in batch reactor using different parameter (diclofenac, pillared clay and pH) in four beakers for 3 hours in jar test instrument, from the result show pH is the important factor effect on the adsorption process and also show diclofenac removal decreased with increasing pH values, but in constant all parameter effect of the initial concentration of diclofenac in the adsorption process show removal of diclofenac increasing with increasing the amount of adsorbent dosage up to 1000 mg. additional, the result of experimental work in packed bed reactor with different variables such as (initial concentration, flow rate and bed depth) for 6 hours, show the best condition of bed depth is 2 cm, initial concentration 625 mg/l and flow rate 25 h/l.

**Keywords-** Diclofenac, adsorption process, batch reactor, packed bed reactor, the pillared clay

**How to cite this article:** F.H. AL Ani, Gh.Y. AL-Kindi and N.Kh. Al-Bidri, "Diclofenac Removal from Wastewater by Iraqi Pillared Clay," *Engineering and Technology Journal*, Vol. 37, Part C, No. 2, pp. 281-288, 2019.

### 1. Introduction

Pharmaceuticals in the last years have become potential bioactive chemicals in the environment. They are causes a rising in pollutants in water bodies and the environment because they remain unfettered or undergoing a regularization process, while the information and legal frameworks are not complex yet. Pharmaceuticals always introduced in the environment and common at small concentrations [1], which have effect in water quality and impact drinking water equipment, ecology, and human health [2]. The presence of pharmaceuticals in water is attributable to personal hygiene products, pharmaceutical industrial waste, hospital waste, and therapeutic drugs. The subsistence of trace pharmaceuticals and other xenobiotic compounds in potable drinking water is another public health concern since little is known about potential chronic health effects associated with long-term ingestion of mixtures of these compounds through drinking water [3]. Pharmaceuticals are a diverse group of chemicals, with varying physical and chemical properties [4]. Treatment efficiency depends on these physical and chemical characteristics (e.g., hydrophobicity), their reactivity towards different treatment processes and process control, such as solids retention time,

temperature and hydraulic retention time. The different water treatment systems in the elimination of pharmaceuticals are especially technologies that use adsorption on activated carbons, advanced oxidation processes (AOPs) that employ ozone, ultraviolet radiation, gamma radiation, and electro oxidation [5], and membrane filtration such as nano-filtration and reverse osmosis [6]. Diclofenac (DCF), a non-steroidal anti-inflammatory drug (NSAID) used to treat rheumatoid arthritis [7]. Diclofenac is a polar pharmaceutical compound mostly used as the sodium salt Diclofenac-Na in human and veterinary medicine to reduce pain and inflammation [8]. Most studies have been carried out on the removal of pharmaceutical preparations that focused on a small group of processes or water treatment processes. Additionally, they have used humic substances extracted from peat instead of water, which have different properties, including a fewer tent of humic acids than fulvic acids, molecules of lower molecular weight and less intensive structures, which may impede the removal of pharmaceutical preparations [9].

The aim of this study uses the pillared clay prepared from AL-Anbar clay to removal the diclofenac from synthesis's wastewater in batch and continuous reactor.

DOI: <https://doi.org/10.30684/etj.37.2C.13>

2412-0758/University of Technology-Iraq, Baghdad, Iraq

This is an open access article under the CC BY 4.0 license <http://creativecommons.org/licenses/by/4.0>

## 2. Materials

### I. Used in prepared pillared clay

Some materials used through the preparation of Al-Anbar clay shown in Table 1.

### II- Diclofenac drug

This study, the diclofenac tablet drug was used in preparation syntheses wastewater from a pharmacy, but the blank diclofenac used in the UV Instrument; it was processed from Samarra pharmaceutical factory.

### III- Diclofenac solution

The diclofenac solution was prepared in four concentrations by used 100- 250-500-1000 gm of diclofenac with 1 L of distilled water.

### IV- Preparation of pillared clay

Clay was collected from AL-Anbar city, which has 70% montmorillonite that used as support to pillared, the stack clays prerational made consistent with Professor N. Papayannakos process (Analysis and plant Design Group at National Technical University of Athens, NTUA). A stock clay suspension (2w %) weighted to be stirred a long period of 48hr. The suspension had been utilized as support. The cationic solution having  $AlCl_3$  (0.18 mol/l) as promoter and  $FeCl_3$  (0.02 mol/l) (molar ratio 9:1) as active component had gradually been titrated with NaOH solution at  $70C^\circ$  until the OH/ cation mole proportion equals to 1.9, the intercalate solution is given to the  $Al^{+3}/Fe^{+3}$  cationic sol under stirring for 1hr and intercalation period and 24hr age time, the intercalated clay had been cleaned carefully by distilled water to remove chloride ions from that clay surface, as returned by the  $AgNO_3$  test according to standard method (4500CL-D). Dried at ( $60-70C^\circ$ ) for 24hr and finally calcined at  $500C^\circ$  for 1hr according to [10], these pillared have been studied the physicochemical properties.

Aluminum Chloride	
$AlCl_3$	Chemical formula
133.34	Molecular Weight
INDIA	Origin
98.0%	Purity
Ferric chloride	
$FeCl_3$	Chemical formula
162.21	Molecular Weight
INDIA	Origin
98.0%	Purity
Sodium Hydroxide	
NaOH	Chemical formula
40	Molecular Weight
England	Origin
Analar	Purity

## 3. Experimental Procedure

Two types of experiments were done, the first one used batch reactor to study the operation condition, also to study the kinetic parameter. The second type used packed bed reactor to study the break through and the bed height.

### A- Batch Experiment

The batch experiment of adsorption was done by using different condition, (diclofenac concentration, adsorbent mass and, pH). In the first stage, the diclofenac solution concentration (100 mg/l) was placed in 4 beakers that capacity (1 L). All operation condition was a constant pH value equal to (7), and temperature ( $22\ 0C$ ). Except for adsorbent materials (pillared clay) for each used different adsorbent mass was (100, 250, 500, 1000 mg). Then 4 beakers were placed in a jar test (figure 1) at (200 rpm), total time 3 hour. Samples were taken at an interval time of 30 min.

Second stage constant the pillared clay concentration in each try in (100 mg/L), also pH value equal to (7), and temperature equal to ( $22\ 0C$ ). With a different mass of diclofenac (100, 250, 500, 1000 mg) with concentration. Then 4 beakers were placed in jar test at (200 rpm), total time 3 hour. Each liquid samples were withdrawn all 30min, filtered and stored to analyse.

Last stage constant the pillared clay concentration in each try in (100 mg/l), also constant of diclofenac concentration for each try (100 mg/l). However, the pH has been used in a different value (2, 5, 7, 9), the temperature equal to ( $22\ 0C$ ). Then 4 beakers were placed in a jar test (figure 1) at (200 rpm), total time 3 hour. Each liquid samples were withdrawn all 30min, filtered and stored to analyse.

**Table 1: The characteristics of the material used in the research**

Characteristics	Parameters
-----------------	------------



Figure 1: show the beakers in the jar test instrument

**B- Continuous operation by packed bed reactor**

*1. Equipment description*

The glass tube of length (60 cm) was used with an internal diameter of (2.1 cm). Different size glass beat was used as a supporter to prevent any missing of adsorbent from the bed and provide the inert zone. The top zone connected valve lead to diclofenac solution pass through bed. However, the bottom zone connected to flow rate

(25 l/sec) to control with flow rate through experimental. The diclofenac solution passing from top to bottom, the wastewater were collected in a plastic container. The diclofenac solution was pumped by using a Submersible pump (water pump) from feed solution to the bed. The schematic diagram for the packed bed reactor shown in Figure 2, and Figure 3 show the packed bed reactor.

**Where**

- 1) feed tank
- 2) pump
- 3) flow meter
- 4) packed bed
- 5) collecting tang

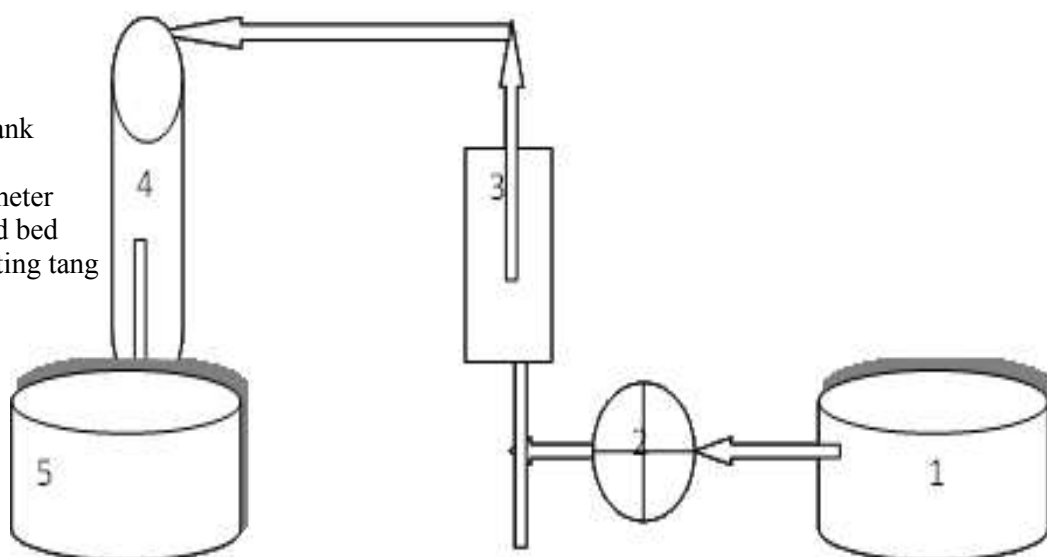

Figure 2: schematic diagram of the system



Figure 3: show the packed bed reactor

## II. Experimental procedure

The experimental procedure for the continuous reactor was carried out at different bed height, flow rate and initial concentration, the produced pillared clay of different adsorbent was put in the adsorption column for certain bed height as shown in Figure 3. In addition, the diclofenac solution was put in feed container and pumped to the tube and passing through the bed from top and inflow had been controlled by a flow meter, the samples withdrawal from effluent in every 30 minutes filtered and stored to analyze.

The operation condition has been used in packed bed reactor (continuous system) for all adsorbent were bed height of produced adsorbents (1, 1.5, 2 cm), initial concentration (100, 400, 625 mg/l) and flow rate 25 l/hr.

## 4. Results and Discussion

The result of the batch reactor (diclofenac concentration, adsorbent mass and, pH). In the beginning the temperature still constant at 22°C and pH 7 and the pillared clay in (100mg/l), and only the concentration of diclofenac was change,

Figure 4 show increase removal of diclofenac with increasing the concentration of it. That is due to pillared clay best removal diclofenac with high concentration. The diclofenac removal increase with increasing time, at the first 40 min increased the diclofenac removal duo to the reaction between the pillared clay with diclofenac drag. In last time, the reaction was finished because of the diclofenac concentration in a very small amount. Said that the intercalation of metals into the clay, thus ensuring uniform porosity with a high interlayer and better insertion of diclofenac potassium and its elimination.

The constant condition temperature 22°C and pH 7 and the diclofenac in (100mg/l), and only the pillared clay was change, the figure (5) show increase the diclofenac removal with increase of pillared clay mass, also show in first time the reaction was get quickly reach to 120min happen the steady state. That due to increasing in pillared clay increase in surface area so that more increase in diclofenac removal.

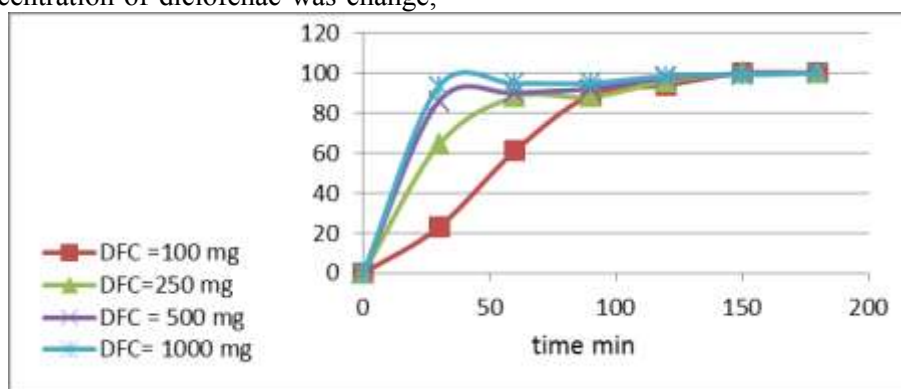

Figure 4: the relative between time and removal efficiency of diclofenac, with constant temperature 22°C, pH 7 and the pillared clay in (100mg/l).

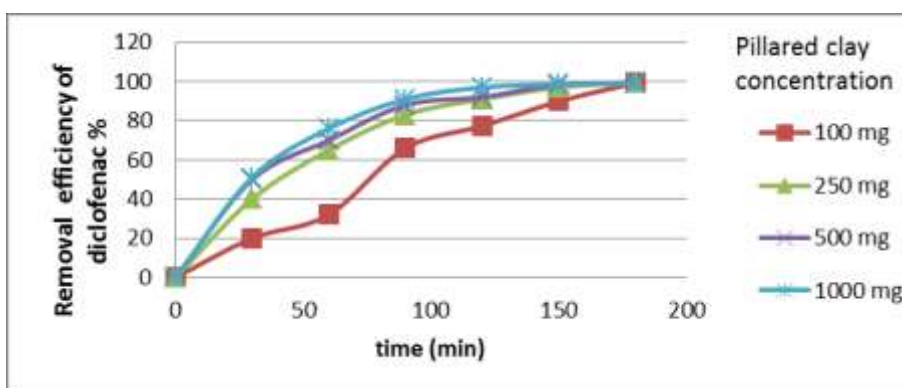

Figure 5: the relative between time and removal efficiency of diclofenac, with constant temperature 22C, pH 7 and the diclofenac concentration in (100mg/l).

The last parameter, change in pH with constant temperature 22C, pillared concentration (100mg/l), and the diclofenac concentration in (100mg/l). Show the uptake of diclofenac potassium decreased with increasing pH. It was observed that the adsorption is highly dependent on the pH of the solution, which affects the surface charge of the adsorbent and the degree of ionization and

speciation of the adsorbate. At lower pH, more protons will be available; thereby increasing the electrostatic attraction between negatively charged diclofenac and positively charged adsorption sites and causing an increase in diclofenac potassium adsorption; these results correspond to the findings [11]. These results show in Figure 6.

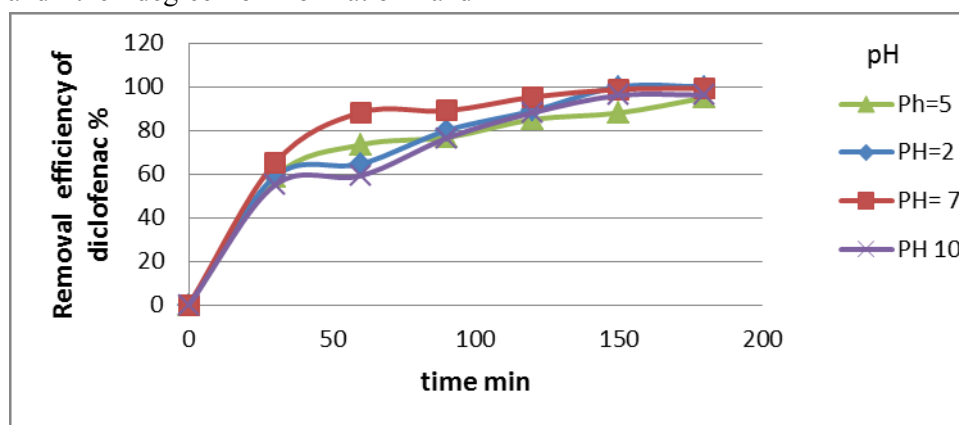

Figure 6: the relative between time and removal efficiency of diclofenac, with constant temperature 22C, pillared concentration, and the diclofenac concentration in (100mg/l).

I. The kinetic models

The isotherm analysis was studied through applying fitting technology for several isotherm models to a chive a suitable model that apply for design objectives. The Freundlich adsorption model, the constant of Freundlich equation

determine by slope, interest linearized by using the equation (1),

$$\ln q_e = \ln K + \frac{1}{n} \times \ln C_e \dots \quad (1)$$

Where k, n constant,  $\frac{1}{n}$  the range between (0-1)

In this study, show the pH was more effect on diclofenac removal, so that, the kinetic adapted on change in pH, as shown in Figures 7.



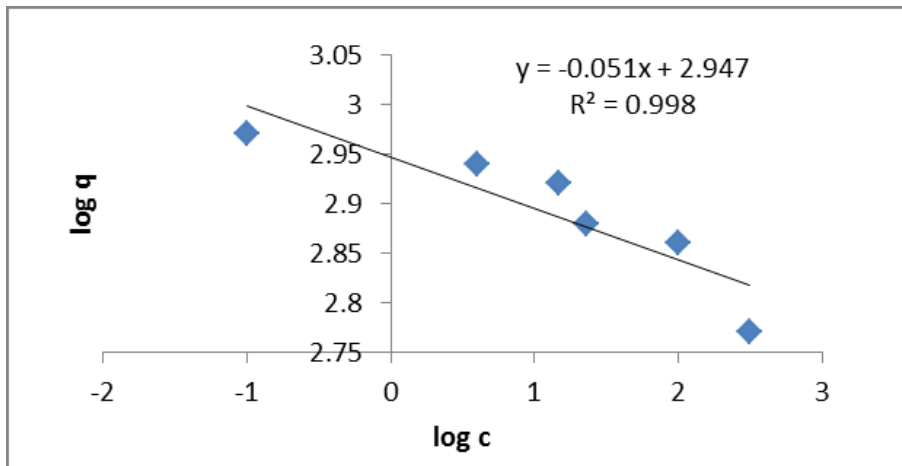

Figure 7: Frundlish mode ( $C_e$ =mg/l, and  $q_e$ = mg/g) for pillared clay adsorbent.

From result show the best fit to the data that give mode constantly, the largest R2 equal to 0.998 ,  $k= 0.46$ , and  $n= 20$

II. Packed bed reactor

From results of packed bed reactor when used different bed height of adsorbent (1, 1.5, 2cm), with initial concentration 625mg/l from potassium diclofenac. The flow rate stays constant 25 l/hr, pH equal to7, the temperature still 22°C, and diclofenac concentration 625mg along the experimental time. The breakthrough curve is shown in Figure 8, respectively. From

result show the breakthrough increase with increase bed height, also show in bed height 1cm the breakthrough observe clearly and rapidly, but in 1.5, 2 cm the breakthrough need more time that due to smaller height has a smaller capacity to adsorb for diclofenac solution, these result accepted with [12].

The flow of solution remains constant; show with increase bed high the contact time increase between adsorbate with a bed, so that the removal efficiency increase too. The best height shows 2cm.

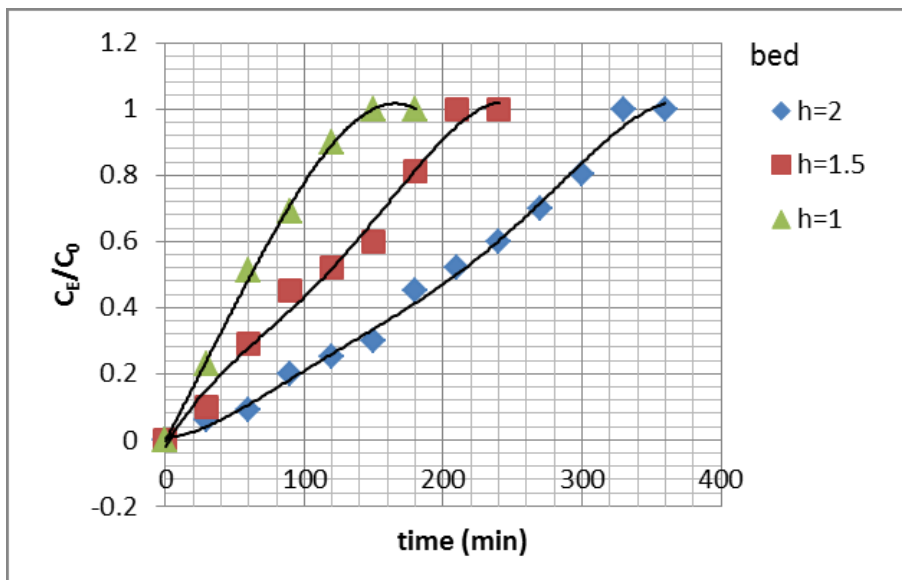

Figure 8: the breakthrough curve of diclofenac adsorption onto pillared clay with different depth and flow rate 25 l/hr. and pH 7

The effect of flow rate show in Figure 9 with constant bed height at 2cm, pH 7, diclofenac concentration 625mg, and temperature 22C, from result show with increase initial flow rate the

breakthrough become steeper that depending on resident time of diclofenac passing on pillared bed, so that resident time decrease with flow rate increase.

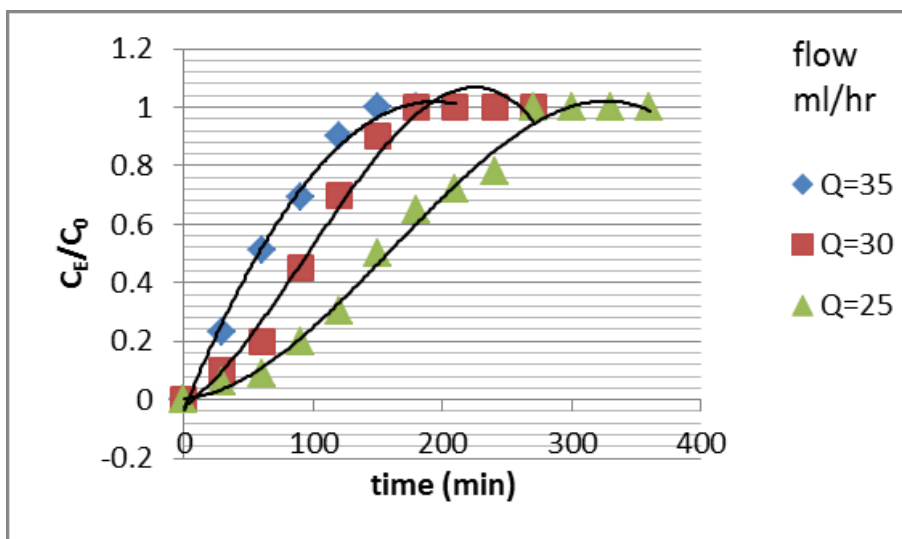

Figure 9: the breakthrough curve of diclofenac adsorption onto pillared clay with depth 2cm, and pH 7, diclofenac concentration 625mg, and different flow rate.

The effect the initial diclofenac concentration (250, 500, 625 mg) on the breakthrough with other parameter kept the constant show in Figure (10) , the bed height 2cm, flow rate 25 l/hr, pH

7, and temperature 22C, show with increase initial diclofenac concentration the breakthrough increase too.

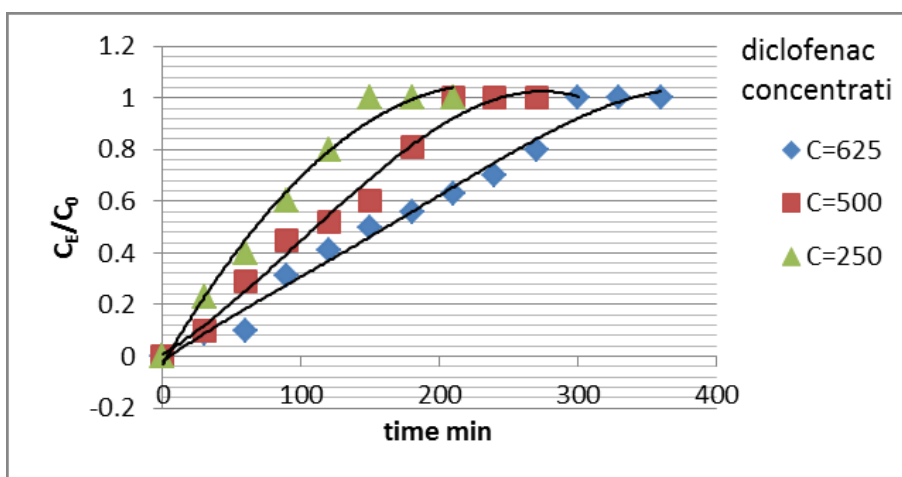

Figure 10: the breakthrough curve of diclofenac adsorption onto pillared clay with depth 2cm, and pH 7 and different diclofenac concentration.

**5. Conclusions**

The conclusion of this study:

1. The pillared clay is the best adsorbent and a good alternative to be as a cheap adsorbent for removal diclofenac from wastewater .
2. From batch reactor, the operation condition was pH 7, diclofenac concentration 1000mg/l, pillared Al-Anbar clay 100mg/l.
3. The Freundlich isotherm was found to be a favorable type for pillared AL-Anbar clay as adsorbents.
4. The break points for the breakthrough curve for pillared clay as increased as the bed height and increase the initial flow rate.
5. The first order was found the kinetic of adsorption.

**References**

[1] D.W. Kolpin, "Pharmaceuticals, hormones, and other organic wastewater contaminants in U.S. streams, 1999–2000: a national reconnaissance," *Environmental Science & Technology*, Vol.36, pp.1202–1211, 2002

[2] X.B. Tung, S.Y. Kang, S.H. Lee, "Heechul Choi.Organically functionalized mesoporous SBA-15 as sorbents for removal of selected Pharmaceuticals from water," *Journal of Hazardous Materials*, Vol.193, pp. 156-163, 2011.

[3] K. Kümmerer, "Pharmaceuticals in the Environment," *Annu Rev Environ Resour*, Vol. 35, pp. 57-75. 2009.

[4] A. Jelic, M. Gros, A. Ginebreda, R.C. Sanchez, "Occurrence, partition and removal of pharmaceuticals in sewage water and sludge during wastewater

treatment,” *Water Research*, Vol. 45, pp. 1165-1176, 2011.

[5] K. Ikehata, N.J. Naghashkar, M.G. El-Din, “Degradation of aqueous pharmaceuticals by ozonation and advanced oxidation processes: a review,” *Ozone-Sci. Eng.*, Vol. 28, pp. 353–414, 2006.

[6] J. Radjenovic, M. Petrovic, F. Ventura, D. Barcelo, “Rejection of pharmaceuticals in nanofiltration and reverse osmosis membrane drinking water treatment,” *Water Res.*, Vol.42, pp.3601–3619, 2008.

[7] D. Krajišnik, A. Daković, A. Malenović, M. Rakić, V. Dondur, T. Radulović, J. Milić, “Investigation of adsorption and release of diclofenac sodium by modified zeolites composites,” *Applied Clay Science*, Vol. 83-84, pp. 322- 326, 2013.

[8] A.Y.C. Lin, T.H. Yu, C.F. Lin, “Pharmaceutical contamination in residential, industrial, and agricultural waste streams: Risk to aqueous environments in Taiwan,” *Chemosphere*, Vol. 74, pp. 131-141, 2008.

[9] A. Berthod., “Solid-phase extraction approach for the identification of pharmaceutical–sludge adsorption mechanisms,” *J. Pharm. Anal.* 2013.

[10] R.V. Andreozzi, Caprio, A. Insola, R. Marotta, “Advanced oxidation processes (AOP) for water purification and recovery,” *Catalysis Today*, Vol. 53, pp. 51, 1999.

[11] B.M. Lombardi, R.M. Baschini, T. Sanchez, “Optimization of parameters and adsorption mechanism of thiabendazole fungicide by montmorillonite of North Patagonia, Argentina,” *App. Clay Sci.*, Vol. 24, pp. 43–50, 2003.

[12] H. M. Abdul- Hameed, “Competitive adsorption of heavy metals onto activated carbon in fixed bed column,” University of Baghdad, College of Engineering Ph.D. Thesis. 2009.