

**Arkan A. Jassim**University of Technology  
[arkan199328@gmail.com](mailto:arkan199328@gmail.com)**Abbas H. Issa** University of Technology  
Bagdad, Iraq  
[30050@uotechnology.edu.iq](mailto:30050@uotechnology.edu.iq)**Qusay A. Jawad** University of Technology  
Bagdad, Iraq  
[Qqaajj92@Gmail.com](mailto:Qqaajj92@Gmail.com)

Received on: 24/01/2019

Accepted on: 17/03/2019

Published online: 25/08/2019

## A Hybrid Neural-Fuzzy Network Based Fault Detection and Isolation System for DC Motor of Robot Manipulator

**Abstract-** In this paper, the detecting and isolating fault that occurs in (actuator and sensor) in robot manipulator, which is used as a mathematical model were proposed for fault detection, where the neural network was used to detect the fault. The neural network was trained on the data set obtained from the Input/output on the (DC motor). The output of the sensor or actuator was compared with the output of the model (neural network) after that the residual signal is used to detect the fault. The fuzzy logic circuit was used for fault isolation that is depending on the residual signal from any sensor or actuator that faults. There are three types of faults detected and isolated in this study abrupt fault, incipient fault and intermittent fault. The Matlab R2012a was used to the model steady state designed and simulated. The model has a high capacity for detecting faults.

**Keywords-** Fault Detection and Isolation, Artificial Neural Network, Fuzzy logic, Manipulator Robot.

**How to cite this article:** A.A. Jassim, A.H. Issa, and Q.A. Jawad, "A Hybrid Neural-Fuzzy Network Based Fault Detection and Isolation System for DC Motor of Robot Manipulator," *Engineering and Technology Journal*, Vol. 37, Part A, No. 8, pp. 326-331, 2019.  
This is an open access article under the CC BY 4.0 license <http://creativecommons.org/licenses/by/4.0>

### 1. Introduction

The primary purpose of using the technique of detecting and isolating fault is the early adopters of operators until appropriate actions are taken before the collapse of the system. Smart techniques are more reliable as well as stop dependence on human beings and especially when systems are complex [1]. The techniques of detecting and isolating faults have become important phenomena in the field of manipulator robots to improve and ensure higher levels of safety and reliability [2]. Because the robotic manipulator is used in a wide range of applications that require very high performance and precision. In addition, the robot manipulator is used in dangerous environments, for example in manufacturing plants, surgical operations and others [3].

In present times, there are many different ways to detect fault, but there are three basic and approved methods: plausibility test, signal-based methods, and model-based methods, Plausibility test is a method that depends on the reasonableness of measured values relative to the raw values measured under normal operation, but faults detecting in this method is less efficient and becomes impossible to complex systems, Signal-based methods is a method that depends on the signals in the detection of faults where the sign bears the symptoms of error and these symptoms, such as the size of the signal or display of signal, time or space or frequency

spectrum or expressions signal or other. Model-based methods are based on comparing actual process behavior with the error-free model at the same input [4].

Previously, there were many kinds of research published in detecting and isolating faults in manipulator robots. In 2014, Mohamed Salah and others used to design and simulate fuzzy logic and neural network for fault detection and isolation (FDI) in sensor and actuator in manipulator robot [5]. In 2015, Amaneh Salmani Rezazadeh and others used nonlinear adaptive fault detection estimator that abled to a two\_ link robot manipulator [6]. In 2016, Hong-Jun Ma and Guang-Hong Yang used observer model\_ based fault detection in sensor and actuator in manipulator robot [7]. In 2017, Cao Thanh Trung and others are using data-driven statistical theory to fault detection and isolation actuator, the sensor in manipulator robot [8]. In 2018, Khaoula Oulidi Omali and others used high gain observers for detection and isolation sensor fault in manipulator robot [8].

In this paper fault detection and isolation in sensor and actuator in manipulator robot, used neural network to build the mathematical model, where the difference between the mathematical model and the system generates the residual which if exceeded by the specified threshold limit for which it is specified leads to a fault line, also a fuzzy logic is used to build the isolation circuit. This paper includes: section 2 explains fault detection and isolation, section 3 explains

the artificial neural network and fuzzy-logic techniques. The simulation results are illustrated in section 4 and civilize the conclusion in section 5.

## 2. Fault Detection and Isolation

System performance and productivity are majorly affected by faults. So FDI is required to deal with these faults to reduce maintenance and cost, thus improving system operation. [9]. For FDI problem, the best way to detect fault is based model were compared the plant output with the model output and the difference between them generate a residual signal. Decision-making depends on the threshold that can be changed to suit the required sensitivity and thus cost the system [10].

In this study, three types of faults were taken Abrupt, Incipient and Intermittent faults. Also, the model is built for robot manipulator parts (actuators and sensors) to detect and isolate the fault that occurs in these parts. Figure 1 shows the general schematic model that generate residual, fault detection and isolation.

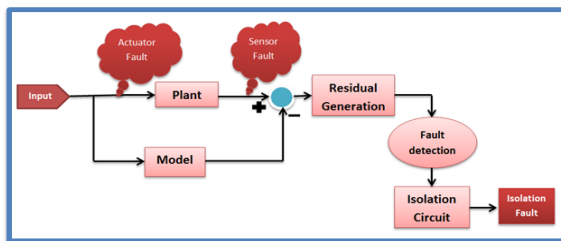

Figure 1: The general schematic model that generate residual, fault detection and isolation.

The plant actuator used in this study (**DC motor**) because it is strong and carries heavy weights. The model of dc motor used in this study.

### I. DC Motor Modeling

The DC motor common actuator considered because it provides rotary motion, Figure 2 shows the electric circuit equivalent of the armature and the free-body diagram of the rotor. The voltage (V) source of this system as the input applied on the armature and translates this voltage into the shaft rotational speed at the output.

Generally, the model of DC motor in Figure ) consists of two parts according to the main parameters form the electrical part: armature resistance (R) and inductance (L), but from the mechanical part the moment of inertia of the rotor (J) and friction of the mechanical system (b). By a constant factor, Kt the generated torque (T) is proportional only with the armature current (i) when the magnetic field is constant as given in

equation (1). This is called motor with armature-controlled.

$$T = Kt i \tag{1}$$

The back electromotive force (e), is proportional by a constant factor Kb to the angular velocity ( $\omega$ ) of the shaft as given in equation (2).

$$e = Kb \omega = Kb \frac{d\theta}{dt} \tag{2}$$

By applying KVL and Newton's law on the circuit of the Figure 2 and convert resulting equations into Laplace transform then re-order those equations, the input voltage V(s) to output position  $\Theta(s)$  transfer function and the input voltage V(s) to output speed  $\omega(s)$  transfer function appear in equation 3 & 4 respectively [15].

$$\frac{\theta(s)}{V(s)} = \frac{K}{s[(Ls+R)(Js+b)+K^2]} \tag{3}$$

$$\frac{\omega(s)}{V(s)} = \frac{K}{[(Ls+R)(Js+b)+K^2]} \tag{4}$$

The block diagram for the DC motor used these equations as shown in Figure 3.

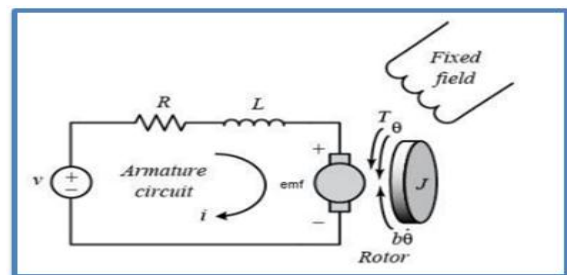

Figure 2: DC motor equivalent circuit and free-body diagram of the rotor [15].

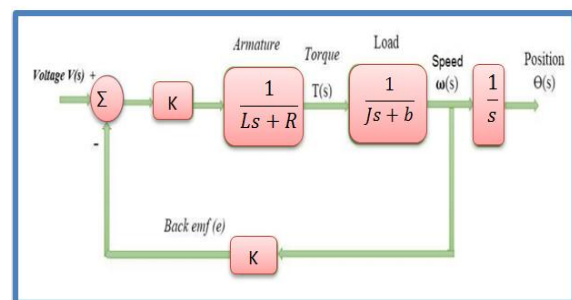

Figure 3: A block diagram of the DC motor.

This study used the output of the DC motor only position because the output of a manipulator robot is position.

## 3. Artificial Neural Network and Fuzzy-Logic Techniques

In this section an explanation in details of neural networks and how to use it as well as an explanation in details of the fuzzy logic and how to illustrate in this paper.

I. Artificial Neural Network Technique

The ANN is artificial cells similar in their work to the neurons of the human brain [11]. The ANN is a technique that has the potential to model a complex system. In this case, neural network connections can be made between inputs and outputs so physical operators are not needed to get the desired outputs [5]. The basic construction of NN consists of an input layer, output layer, and a hidden layer or layers. Basically, the NNs divided into two types the feed forward, and the feedback (recurrent) NNs. In first type feed forward Flow of the signal in the forward direction from one neuron to another. There are many ways to train NNs but the most common is the algorithm of back propagation which the signal error has propagated from layer output to layer input [12].

An artificial neuron comprises of three essential parts; weights, thresholds, and a single activations-functions, as shown in Figure 4.

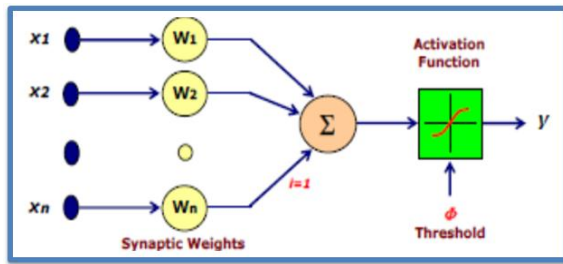

Figure 4: DC Artificial neuron model.

**Weightings-Factors (w):** The values  $w_1, w_2, \dots, w_n$  are weights which determine the input vector strength  $\mathbf{X} = [x_1, x_2, \dots, x_n]^T$ . Each input is multiplied by the associated neuron connection weights  $\mathbf{X}^T \mathbf{W}$ .

**Thresholds ( $\Phi$ ):** The node's internal thresholds  $\Phi$  is the magnitudes offsets. It affects the node output activations  $y$  as:

$$y = f \left\{ \sum_{i=1}^n (x_i w_i) + \Phi \right\} \quad (5)$$

**Activations-Functions** An activation-function ( $f$ ) performs a mathematical operations on the outputs of the signal [16, 17].

In this paper, the Multi-Layer Perceptron (MLP) neural network was used because it is very simple and shows amazing results. It consists of one input and one output layer and two hidden layers as shown in Figure 5.

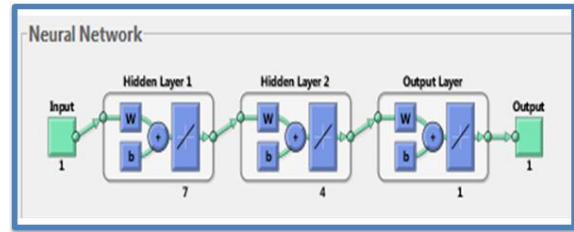

Figure 5: Input and output and two hidden layers in the neural network.

The parameter of this neural network as shown in Table 1.

Table 1: Neural network parameters.

<b>Number of neurons first hidden layer</b>	7
<b>Number of neurons second hidden layer</b>	4
<b>Training Function</b>	Purline
<b>Goal</b>	1e-9

II. Fuzzy-Logic Technique

Fuzzy logic is one type of intelligence working with the logical algorithms used to simulate thinking human and making the decision in machines. [13]. In 1965, the Iranian scientist Lutfi Zadeh was the first who introduce the idea of fuzzy logic with an unbalanced boundary that provides the basis for the analysis of complex systems that use linguistic words instead of numerical words to describe the system's performance and behavior [14]. The fuzzy logic has three stages: the first stage is fuzzification, the second stage is controlled rules evaluation and the third stage is defuzzification. In the first stage fuzzification, is converted input variables of crisp values into fuzzy values through the fuzzy sets and membership functions (MF). Then, the values of the fuzzified inputs are assessed through the control rules (IF then) and the control outputs are generated. After that converted back Fuzzy output to crisp values by one of the different defuzzification method [5].

In this paper, fuzzy logic was used to isolate the fault in manipulator robot. Fuzzy logic that consists of six inputs and one output because the manipulator robot suggested in this paper content three joints and each joint includes two parts actuator and sensor, so it is used six inputs. The amplitude of the output bounded by any part is fault, when the output is zero that no fault. The fuzzy isolation circuit is shown in Figure 6 and its components internal is shown in Figure 7.

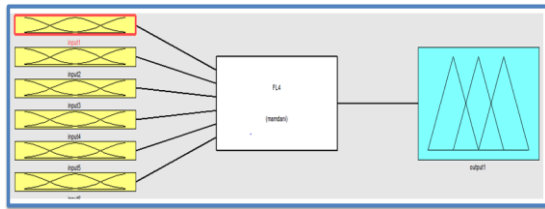

Figure 6: DC Fuzzy Isolation circuit.

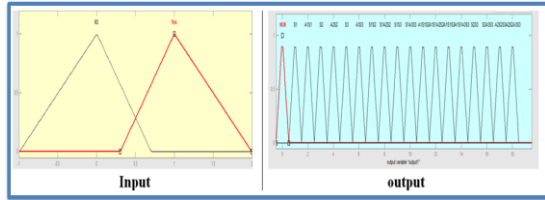

Figure 7: Fuzzy Internal components of fuzzy isolation circuit.

The type of membership function used is triangular versions, and Mamdani’s Fuzzy Inference Method used to interface between input and output.

The fuzzy isolation circuit output defines the fault. These numbers of output are used to determine the location of the fault. With all membership functions of the input and output defined the rule base needs to be defined as follows:

1. If (F.s1 is NO) and (F.a1 is NO) and (F.s2 is NO) and (F.a2 is NO) and (F.s3 is NO) and (F.a3 is NO) then (output1 is (0))
2. If (F.s1 is Yes) and (F.a1 is NO) and (F.s2 is NO) and (F.a2 is NO) and (F.s3 is NO) and (F.a3 is NO) then (output1 is (1))

In addition, the other rules are shown in the Table 2, the number of probability equal (64) because of the number of inputs equal six, according to the equation:

Number of probability =  $2^6 = 64$ . So the probability ranges from 0 to 63.

Table 2: The number of probability in fuzzy isolation circuit.

Isolation circuit input						Isolation output
F.s1	F.a1	F.s2	F.a2	F.s3	F.a3	Amplitude of output
NO	NO	NO	NO	NO	NO	0
Yes	NO	NO	NO	NO	NO	1
NO	Yes	NO	NO	NO	NO	2
NO	NO	Yes	NO	NO	NO	3
NO	NO	NO	Yes	NO	NO	4
NO	NO	NO	NO	Yes	NO	5
NO	NO	NO	NO	NO	Yes	6
Yes	NO	Yes	NO	NO	NO	7
Yes	NO	NO	Yes	NO	NO	8
Yes	NO	NO	NO	Yes	NO	9
Yes	NO	NO	NO	NO	Yes	10
.	.	.	.	.	.	.
.	.	.	.	.	.	.
.	.	.	.	.	.	.

Yes	Yes	Yes	Yes	Yes	Yes	63
-----	-----	-----	-----	-----	-----	----

Hint: where F.a is (fault actuator), F.s is (fault sensor), Yes is (fault), and NO is (no fault).

4. Simulation Results

The physical parameters of the actuator (DC motor) used in this paper are given in Table 3.

Table 2: The parameter's values for DC motor [18].

Physical parameter	Symbol	Value	Unit
Damping of the mechanical system	b	0.1	Nms
Back-electromotive force constant	K	0.01	Nm/A
Moment of inertia of the rotor	J	0.01	Kg.m <sup>2</sup>
Electric inductance	L	0.5	H
Electric resistance	R	1	Ω

By substituting these values in equation 3, the T.F. of the position that shown below:

$$\frac{\theta(s)}{V(s)} = \frac{0.01}{s[(0.5s+1)(0.01s+0.01)+0.0001]} \tag{6}$$

Fault detection in manipulator robots parts (actuators and sensors) use a neural network model .While fault isolation used fuzzy logic, the Matlab R2012a used in this study, the general system simulation used is shown in Figure 8.

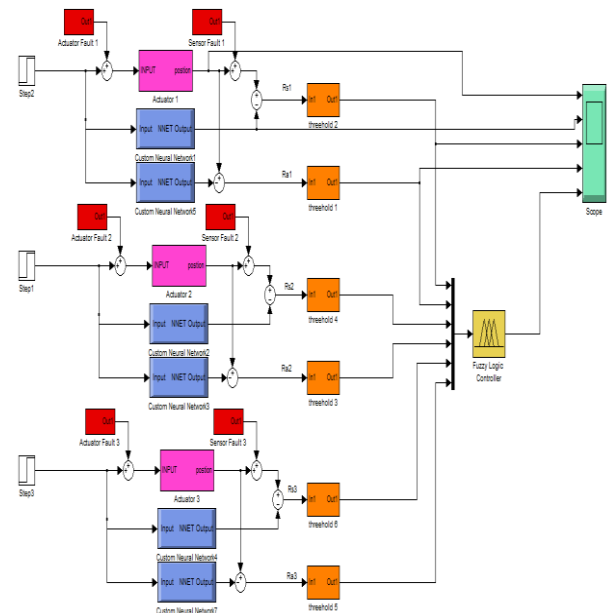

Figure 8: The general system simulation

I. Abrupt fault

Abrupt fault can be represented by the step signal to add in the first sensor after 12 seconds, the simulation shows in the Figure 9 and 10.

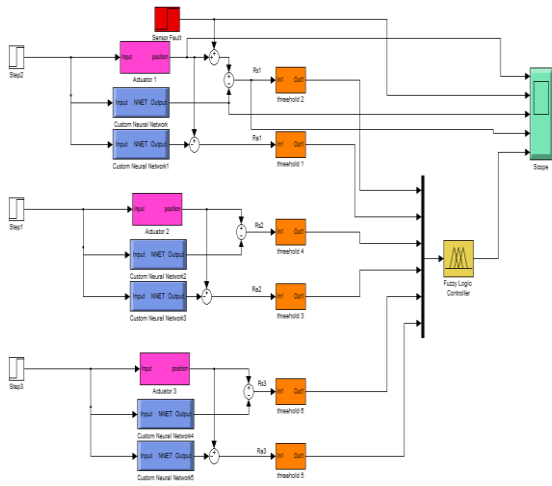

Figure 9: Abrupt fault in sensor1

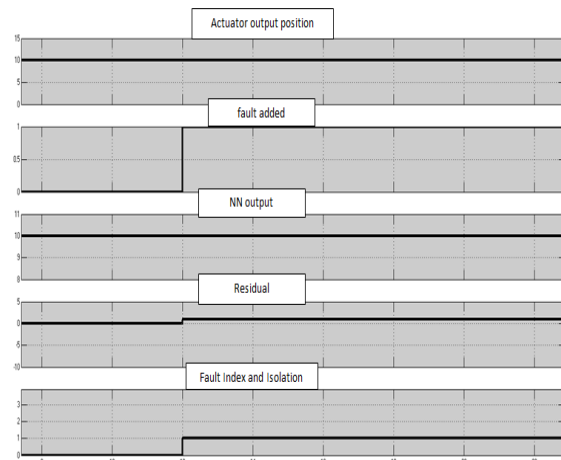

Figure 10: Abrupt fault addition signals

**II. Incipient fault**

Represented the Incipient fault by ramp signal added in the second actuator after 12 seconds. The Incipient fault occurs due to high temperature, and continuous operation. When the actuator is fault, the sensor also is the fault automatically. The output of the isolation circuit given the amplitude is 4 this means the actuator 2 is the fault, the shape of the ramp and other signals are shown in Figure 11.

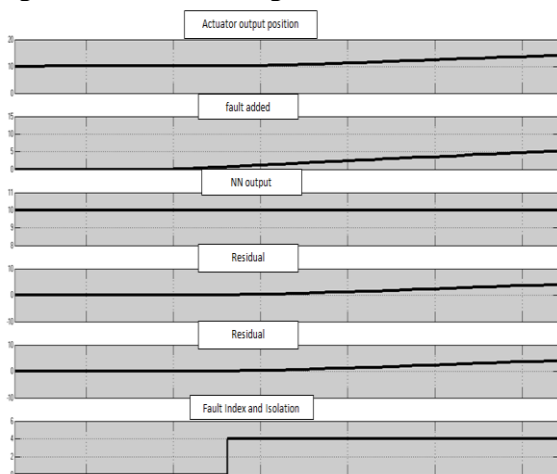

Figure 11: incipient fault addition signals.

**III. Intermittent fault**

Represented the intermittent fault by Random signal is added to the third sensor3 after 12 seconds, the intermittent error can occur due to voltage fluctuation, the output of the isolation circuit given the amplitude is 5 this means the sensor3 is the fault. The shapes of the random and other signals are shown in Figure 12.

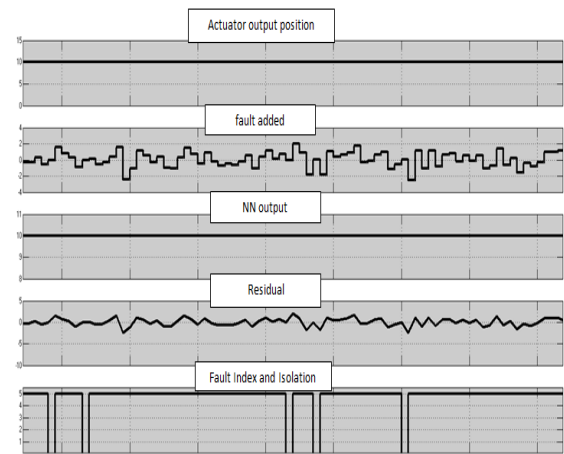

Figure 12: intermittent fault addition signals.

**5. Conclusion**

In this study, the black box (neural networks) was used to detect the fault in the manipulator robot parts (Actuators and Sensors). Then, the fuzzy logic was used to design the isolation circuit to isolate the fault location. The model (neural network) is used and designed only for steady state analysis (the startup or transient changes of the parameters are neglected). The system gives the user good results in detecting and isolating the fault. Also can be hardware implementation download on Field Programmable Gate Array (FPGA) card.

**References**

[1] H.M. Khalid, and M. Akram, "Fault Modeling, Detection and Classification using Fuzzy Logic, Kalman Filter and Genetic Neuro-Fuzzy Systems," Asian Journal of Engineering, Sciences & Technology, Vol. 1, No. 2, 45-57, 2011.

[2] K.O. Omali, M.N. Kabbaj, and M. Benbrahim. "Fault Diagnosis for Manipulator Robot using Observers-Based Approaches," International Meeting on Advanced Technologies in Energy and Electrical Engineering, 1-9, 2018.

[3] A.T. Vemuri, M.M. Polycarpou, and S.A. Diakourti, "Neural Network Based Fault Detection in Robotic Manipulators," IEEE, Vol. 14, No. 2, 342-384, 1998.

- [4] M. Abid, "Fault detection in nonlinear systems: An observer based approach," Ph.D. thesis, Duisburg-Essen University, 2010.
- [5] M.S. Khireddine, K. Chafaa, N. Slimane, and A. Boutarfa, "Fault Diagnosis in robotic manipulators using Artificial Neural Networks and Fuzzy logic," LRP & LEA Labs. Electronics Department, Batna University Batna . IEEE, 2014.
- [6] A.S. Rezazadeh, H.R. Koofgar, and S. Hosseinnia, "Adaptive fault detection and isolation for a class of robot manipulators with time-varying perturbation," *Journal of Mechanical Science and Technology*, 4901-4911 Springer 2015.
- [7] H-J. Ma, and G.-H. Yang, "Simultaneous fault diagnosis for robot manipulators with actuator and sensor faults," *Information Sciences* 366, 12–30, 2016.
- [8] C.T. Trung, H. M. Son, D. P. Nam, T. N. Long, D. T. Toi, and P. A. Viet, "Fault Detection and Isolation for Robot Manipulator Using Statistics," *International Conference on System Science and Engineering (ICSSE) IEEE*, 340-343, 2017.
- [9] M. Md Kamal and D. Yu, "Fault Detection and Isolation using RBF Networks for Polymer Electrolyte Membrane Fuel Cell," *World Academy of Science, Engineering and Technology International Journal of Electrical and Computer Engineering*, Vol:7, No:4,pp. 459-463, 2013.
- [10] A.H. Issa, H.M. Hadi, "Intelligent Fault Detection for Proton Exchange Membrane Fuel Cell PEMFC Based on Artificial Neural Network ANN," *Al-Mansour University College / Proceeding of 15th Scientific Conference* pp. 207-218, 23-24, 2016.
- [11] Daniel graupe, "Principles of Artificial Neural Networks," Second edition, World Scientific Publishing Co. Pte. Ltd., Vol. 6, 2007.
- [12] A.P. Engelbrecht, "Computational Intelligence," 2nd Edition, John Wiley and Sons, Ltd., 2007.
- [13] L.A. Bryan, and E.A. Bryan, "Programmable Controllers: Theory and Implementation," 2nd Edition, Industrial Text Company, U.S.A, 1997.
- [14] S. Dash, R. Rengaswamy, V. Venkatasubramanian, "Fuzzy logic based trend classification for fault diagnosis of chemical processes," *Elsevier Science, Computers and Chemical Engineering*, Vol. 27, pp. 347-362, 2003.
- [15] A. Telba, "Motor Speed Control Using FPGA," *IEEE, Proceedings of the World Congress on Engineering*, London, UK, Vol. I. July 2 - 4, 2014.
- [16] A. Konar, "Artificial Intelligence and Soft Computing Behavioral and Cognitive Modeling of the Human Brain," CRC Press, 2000.
- [17] K. Mehrotra, C.K. Mohan, and S. Ranka, "Elements of Artificial Neural Networks," Massachusetts Institute of technology, 2000.
- [18] A.H. Issa, and A.N. Abd, "Adaptive Inverse Neural Network Based DC Motor Speed and Position Control Using FPGA," *Diyala Journal of Engineering Sciences*, Vol. 11, No. 3, pp. 71-78, 2018.