



Flexural Properties of Functionally Graded Polymer Alumina Nanoparticles

Mahdi M. S. Shareef ^{a*}, Ahmed N. Al-Khazraji ^b, Samir A. Amin ^c

^a Mechanical Engineering Department, University of Technology/ Baghdad-Iraq, hjr.majeed@gmail.com

^b Mechanical Engineering Department, University of Technology/ Baghdad-Iraq, 20043@uotechnology.edu.iq

^c Mechanical Engineering Department, University of Technology/ Baghdad-Iraq, 20061@uotechnology.edu.iq

*Corresponding author.

Submitted: 11/12/2020

Accepted: 05/03/2021

Published: 25/05/2021

KEY WORDS

Epoxy; Al₂O₃ nanoparticles; Polymer nanocomposites; FGMs; Tensile properties; Compression properties; Flexural properties

ABSTRACT

In this paper, a functionally graded polymer nanocomposite (FGPNC) was arranged via mixing the Alumina (Al₂O₃) nanoparticles (50 – 100 nm) with an epoxy matrix through five layers of 1.2 mm thickness for each layer using hand lay-up technique. Different volume fractions were taken (0, 1, 2, 3 and 4) % of the used nanoparticles and were cast in molds made from acrylic for creating the graded composite sheet in the thickness direction. The prepared isotropic specimen was tested by tensile and compressive test. The results showed that the (4% Vf of Al₂O₃) has the best enhancement of the ultimate tensile strength (85.25% from neat epoxy) and decreased thereafter. Flexural properties of three different types of functionally graded materials (FGMs), including FGM1, FGM2 and FGM3, isotropic nanocomposite (2% Al₂O₃) and pristine epoxy were obtained. Flexural strength and flexural modulus of the functionally graded polymer nanocomposite for each type of FGMs enhanced by (51.7%) and (67%), respectively for the FGM1 loaded from the neat epoxy side, whereas for the FGM1 loaded from the (4%) side, the improvement in these properties was (17.8%) and (29.4%), correspondingly over those for the neat epoxy. For FGM2, the improvement in the flexural strength was (27%) and (71.8%) for the flexural modulus as compared with pristine epoxy. The enhancement in the flexural strength of FGM3 was (27%) and flexural modulus (57.7%). Design Modeler (ANSYS Workbench) was used to verify the experimental flexural test results. A very good agreement was found between the experimental and numerical results with a maximum error of (3.92%) in the flexural modulus for FGM1 loaded from the composite side.

How to cite this article: Mahdi. M. S. Sharif, Ahmad. N. Al-Khazraji, Samir. A. Amin, "Flexural Properties of Functionally Graded Polymer Alumina Nanoparticles," Engineering and Technology Journal, Vol. 39, Part A, No. 05, pp. 821-835, 2021.

DOI: <https://doi.org/10.30684/etj.v39i5A.1949>

This is an open access article under the CC BY 4.0 license <http://creativecommons.org/licenses/by/4.0>

1. INTRODUCTION

FGMs are inconsistent composites comprising (2) or extra materials so that their composition changes in a gradual manner in certain spatial direction. Therefore, FGMs possess the needed characteristics of every component in it, making the functionally graded materials more appropriate for attaining the requirement of the operational environment than a consistent material. The functionally graded material idea was initially conceptualized in 1984 in Japan and it has appealed the designer's attention for combining (2) or further than (2) entirely dissimilar materials for obtaining a fresh material having characteristics for facing the challenging uses. Functionally graded polymer materials are the current progress in the FGMs field [1].

Precisely, concerning the functionally graded nanocomposites with a matrix of a pristine liquid phase such as the epoxy, the restricted experimental endeavours have been documented because of the deficiency of the dependable and broadly proper processing methods [2]. Aminosilane modified (MWCNTs) and salinized nano-TiO₂ were used for making (MWCNTs) and nano-TiO₂ based, respectively, and the functionally graded epoxy nanocomposites were prepared via the centrifugation of the mixtures of epoxy through their process of curing. Nevertheless, owing to the centrifugation operating principle, samples were restricted to a cylindrical form and merely a single distinctive pattern of gradient can be determined.

Aysser A. Al-Ameery et al. [3] prepared an epoxy/Al₂O₃ nanocomposite with a weight fraction of (1, 1.5, 3 and 5%). The nanocomposite synthesis procedure is the technique of a High-Shear mixing pursued via the process of curing at (80°C). Characteristics of the arranged alumina nano filler epoxy-based matrix composite was evaluated, including testing some of mechanical properties tests (i.e., tensile, creep, impact, compression, bending, flexural, shear and wear), and some physical properties tests (i.e., thermal conductivity and dielectric constant).

Ibtihal-Al-Namie et al. [4] In this study, epoxy resin is fabricated using conventional filler (aluminum oxide (Al₂O₃) and silicon oxide (Quartz) (SiO₂). Involves studying the effects of weight fraction and the type of the reinforcement particulates on the mechanical properties of the composite materials which include tensile, compression, bending, impact, and hardness.

Sudhir Kumar Mishra et al. [5] prepared a layered FGPNC via distributing the nanoparticles of Al₂O₃ in a matrix of epoxy by ultra-sonication. The weight fraction change of the nanoparticles of alumina was given in the direction of thickness for attaining the gradation. Layers having a thickness of (1 mm thickness) of the neat epoxy, (0.25 wt.%), (0.5 wt.%), (0.75 wt.%), and (1 wt.%) of the nanocomposites of epoxy-Al₂O₃ were consecutively cast in vertical acrylic molds for synthesizing the graded composite sheet having a thickness of (5 mm). The nanocomposites tensile characteristics for every weight fraction were obtained, whereas the flexural characteristics were obtained for FGPNC via performing a 3-point bending test burdened from the neat and (1 wt.%) side. The highest increase in the tensile characteristics was reported for the nanocomposites with (1 wt.%) nanoparticles [5].

Tsotra and Friedrich [6] investigated the flexural characteristics of the functionally graded epoxy-resin/carbon fiber composites, the centrifugation technique was used to create a graded distribution of carbon fibers in an epoxy resin matrix, and the flexural modulus and strength of the functionally graded material were influenced via the graded structure. Owing to the lower cost and better chemical resistance and capability for making a bond to the matrix of epoxy, the particles of Al₂O₃ are depicting an important interest for the nano-scale polymer reinforcement. The elasticity modulus rose with the concentration of nanoparticles. The modulus increment is anticipated since the Al₂O₃ modulus E = 360 GPa [7] is much greater than the modulus of the matrix of epoxy 3.2 GPa [8].

Numerous research works have been documented on the simulation of different characteristics of the functionally graded polymer nanocomposites [9 –13]. While, the experimental work of these nanocomposites is insufficient. Therefore, in this study, alumina nanoparticle was used as reinforced material, and the epoxy matrix was utilized. Different samples of FGMs were utilized and compared with the epoxy and isotropic composites by three-point bending test. An experimental test was compared with a finite element model and elucidated a good agreement for flexural test.

2. EXPERIMENTAL PART

2.1 Material used

Epoxy resin of a trademark (Quickmast 105 base) was utilized as the matrix, which is a low viscosity epoxy in comparison with the other thermosets, and it was converted into a state of solid via the addition of a hardener (Quickmast 105 hardener) at a ratio of (4:1.47). The technical properties of Quickmast 105 depending on the data sheet of DCP Company are given in Table I, while the nanoparticle reinforcements are alumina manufactured by Briture Co. Ltd. Their technical properties are depicted in Table II.

TABLE I: Technical properties of Quickmast 105 at 7 days (from the data sheet of supplier)

Compressive strength	Flexural strength	Tensile strength	Density	Viscosity	Poisson's Ratio
50 MPa	82 MPa	28 MPa	1.15 g/cm ³	3-5 poise at 25°C 1-2 poise at 35°C	0.33

TABLE II: Technical properties of nano alumina (from the data sheet of supplier)

Properties	Values
Purity (%)	99.9
Average particle size (nm)	50-100
Specific surface area (m ² /g)	5-10
Microstructure shape	Spherical
Poisson's ratio	0.22
Young's modulus (GPa)	347

2.2 Nanocomposites preparation

Moulds having a thickness of (6 mm) of acrylic were machined via CNC laser machine. Nanocomposites were synthesized by hand lay-up technique. In the present research, nano alumina being selected as nanofillers, and the liquid epoxy was used as matrix.

To prepare the samples of neat epoxy for creating equal situations in comparison with the other samples, an appropriate quantity of epoxy resin was poured into a sufficient quantity of thinner solvent. After (15 min) of mixing in a magnetic stirrer, this mixture was poured into a beaker to put in a vacuum vessel, and the solvent should be evaporated completely beneath the vacuum state produced by a vacuum pump. In such step, a hardener stoichiometry ratio, i.e., 4 (epoxy resin)/1.47 (hardener), was supplemented and mixed consistently for (15 min) and degassed via the vacuum pump for removing the bubbles of air, as revealed in Figure 1. This mixture was poured into an acrylic mould and cured for (24 h) at the room temperature.

In order to prepare isotropic epoxy/ SiO₂, the desired amounts of reinforcements (0.5, 1, 1.5, and 2 % Vf.) were dissolved into the adequate quantity of the stated solvent for (15 min). The resulting mixture was made uniform via magnetic stirrer for (15 min) and sonicated at (75%) amplitude for (15 min); 50s ON and 10s OFF. The demanded quantity of epoxy resin was supplemented to such mixture by the similar technique as stated earlier and was mechanically mixed. The stoichiometry ratio of hardener was added to this mixture and was mechanically stirred and degassed by a vacuum pump to remove the air bubbles. Finally, the homogenous mixture was poured into acrylic moulds and cured for one day.

It is important to note that the addition of nanoparticles increased the viscosity of the epoxy during the fabrication; therefore, the limitation on the upper bound of the nano alumina content was set as 5% Vf. of epoxy.

Different acrylic moulds were used in this work (Figure 2), square mould having a size of 225 mm × 225 mm × 6 mm, and the other moulds were cut from the acrylic sheets of 6 mm thickness by CNC laser machine according to the ASTM standards for different types of tests and the cylindrical moulds for compression test.

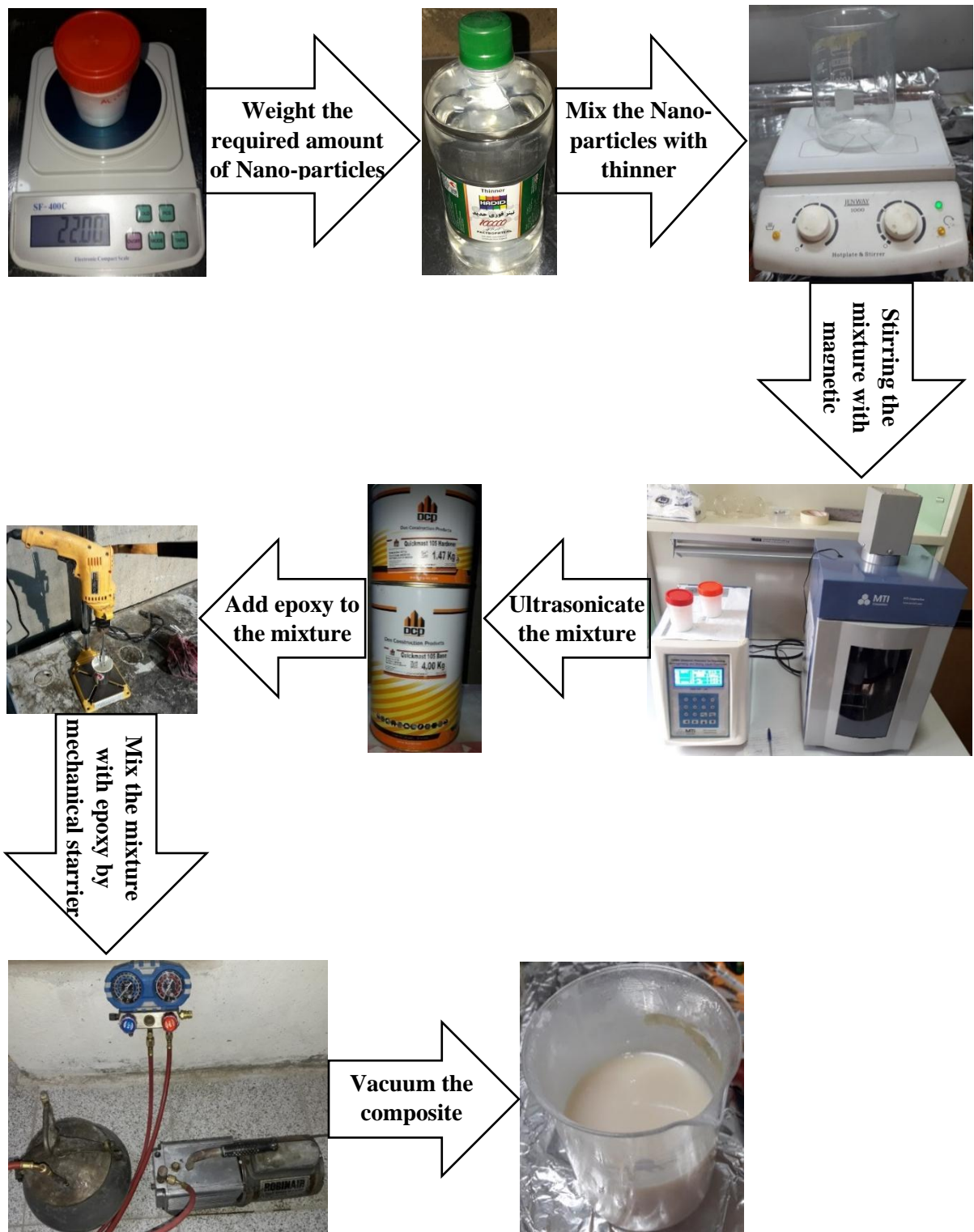

Figure 1: Tools used in experimental work to fabricate homogenous and functionally graded nanocomposite.

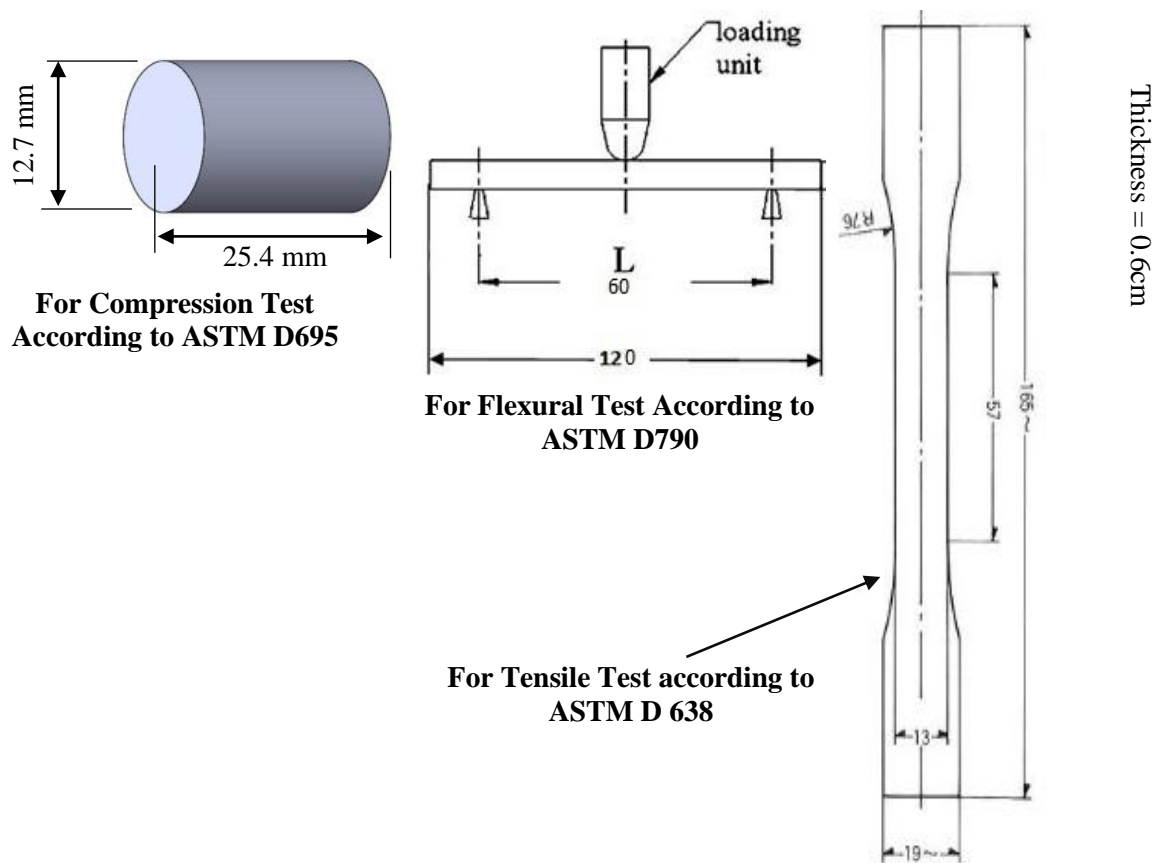

Figure 2: Acrylic molds for homogenous composite and FGM's

2.3 Preparation of FGPNC

Functionally graded polymer nanocomposite (FGPNC) samples have different types, as shown in Figure 3. The fabrication process of these nanocomposites was divided into dual distinctive stages: the preparation of mixture of the nanofiller and liquid matrix by appropriate dispersion and mixing methods as in the above technique for isotropic nanocomposite and consecutively casting the liquid mixture into layered molds depending upon the predesigned graded structure. Such layers having a thickness of (1.2 mm) were cast into the acrylic molds. For FGM1, the initial needed quantity of mixture for the neat epoxy was poured quietly into a mold having a cavity with a thickness of (1.2 mm). The mixture was then cured for 1 hour. Then, a single layer of nanocomposites with (1% Vf.) of the alumina nanoparticles was cast upon the formerly cast semi-cured layer. This layer was then cured for 1 hour. Likewise, (3) more nanocomposites layers of 2, 3 and 4% Vf. of alumina nanoparticles were cast one by one for fabricating the sheet of the functionally graded polymer nanocomposite having a thickness of (6 mm), and the similar process was repeated for the other FGMs samples.

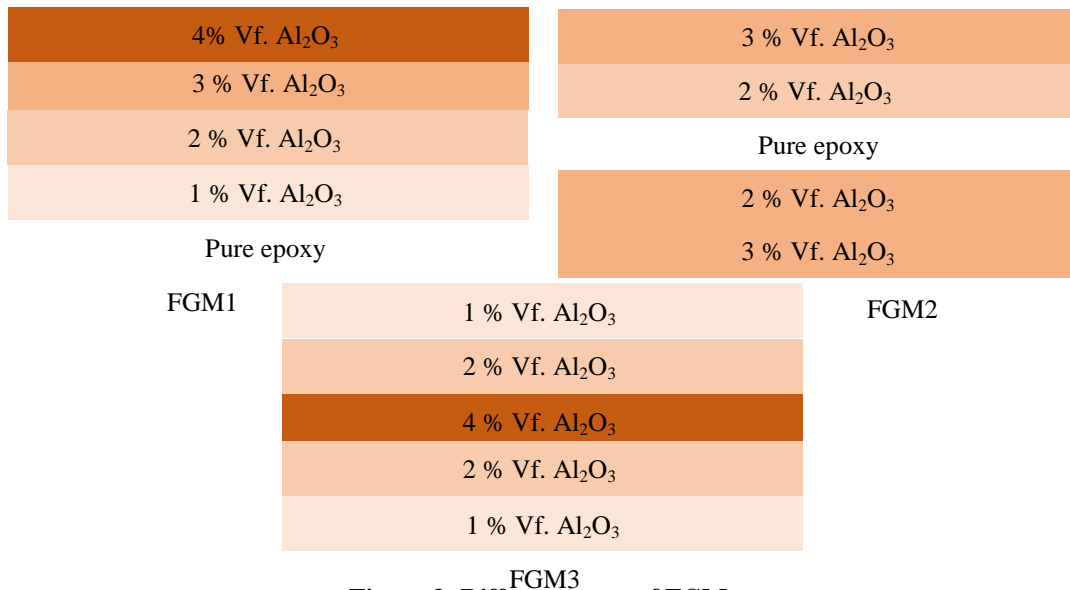

Figure 3: Different types of FGMs

3. CHARACTERIZATION

The characterization of nanocomposites and functionally graded nanocomposites can be classified into two broad categories: mechanical and physical characterization. Mechanical characterization is to determine the mechanical properties (Tensile, flexural and compression) of the individual nanocomposite and FGPNC. The physical characterization is to evaluate the density of nanocomposites and FGPNC.

3.1. Physical Characterization (Density)

The theoretical density (ρ_{th}) of composite was computed with the rule of mixture (ROM), using the following expression [14]:

$$\rho_{th} = V_p \rho_p + V_e \rho_e \tag{1}$$

Where, V_p , V_e , ρ_p , and ρ_e are the volume fraction and the density of nanoparticles and the matrix of epoxy, correspondingly.

The density of the samples of the epoxy and the functionally graded polymer nanocomposite were experimentally obtained employing the principle of Archimedes principle. The composites density was computed utilizing the following expression [14]:

$$\rho_c = \frac{W_a}{(W_a + W_w)} \tag{2}$$

Where ρ_c is the composite density, and W_a and W_w are the sample weights in air and water, correspondingly.

3.2. Mechanical characterization

3.2.1. Tensile and compressive test

Tensile and compressive properties of the samples of nanocomposite at different volume fractions were obtained according to the (ASTM standard D638) [15] and (ASTM D 695) [16] respectively, using 50 kN servo hydraulic computerized Universal Testing Machine UTM (Tinius

Olsen H50KT apparatus), as shown in Figure 4. These tests were conducted at (1 mm/min) crosshead speed. The average Young's modulus and strength were computed via performing (5) valid tests at least.

The tensile and compressive strength of the test samples were calculated using the following equation [17]:

$$\sigma = \frac{P}{A} \quad (3)$$

Where, σ is the stress, P is the load applied, and A is the area of cross section normal to the direction of applied load.

The modulus of samples was calculated by dividing the tensile or compressive stress on the strain in the linear part of the stress-strain curve between the values of strain (0.05%) and (0.25%), utilizing the equation bellow [17]:

$$E = \frac{\sigma_2 - \sigma_1}{\varepsilon_2 - \varepsilon_1} \quad (4)$$

Where, ε_1 is the 0.0005 strain, ε_2 is the 0.0025 strain, σ_1 is the stress at ε_1 , and σ_2 is the stress at ε_2 .



Figure 4: Universal testing machine and samples used

3.2.2. Flexural Test

In the samples of the functionally graded polymer nanocomposite, the gradation being delivered in the direction of thickness, which means the characteristic (stiffness) is changing in the direction of thickness. Flexural properties of neat epoxy, 2% Vf. alumina nanocomposite, and FGM's were obtained utilizing a 3-point bending test. The samples were burdened from the epoxy side and the nanocomposite side upon the universal testing machine for FGM1 and one side for the other

samples. The flexural test sample dimensions are 60 mm length (L), 10 mm width (W), and 6 mm thickness (B), respectively as shown in figure 2 according to the ASTM D790. Flexural strength, flexural strain and flexural modulus were calculated by the following equations [14].

$$\sigma_f = \frac{3PL}{2WB^2} \quad (5)$$

$$\varepsilon_f = \frac{6DB}{L^2} \quad (6)$$

$$E_b = \frac{mL^3}{4WB^3} \quad (7)$$

Where, σ_f is the flexural stress, ε_f is the flexural strain, E_b is the flexural modulus, P is the maximum load, D is the deflection, and m is the tangent slope to the first linear region of the Load-Deflection curve. As a minimum, (5) samples were tested for every sample type.

In the present investigation, the diameters of the support roller and the loading nose were (10 mm), respectively.

4. FINITE ELEMENT MODELING AND ANALYSIS (NUMERICAL MODELING)

The finite element method is accurate and is the most elegant method of modelling complex three-dimensional composite materials. This study presents the details of a 3-D finite element modelling and analysis to simulate the progressive failures in composite materials for a three-point bend test to study the effects of nanoparticles on the beam of composites. The models were developed using the ANSYS finite element software. The flexural modulus of the functionally graded nanocomposites was estimated employing the (ANSYS Multiphasic code, version 16.1) software. The friction between the jigs and the sample wasn't regarded in the present work. The functionally graded nanocomposites layers were regarded as a single consistent isotropic elastic substance for each layer.

The model of the finite element of the flexural tests was made, as depicted in the Figure 5. The total nodes were 50892 (sample: 34240, jigs: 16652). In such model, the Cartesian coordinate system was utilized with the X-, Y-, and Z-axes in the direction of length, width and thickness, correspondingly. 8-node solid 186 elements were employed to mesh the samples. It was assumed that the friction coefficient for the contact surfaces was zero. The sample was loaded via prescribed displacement (δ_0) in the Z-direction upon the upper surface of loading nose. The calculated load (P_0) corresponding to the load was measured by a load cell in the experiments. The Poisson's ratio for each layer was calculated for different volume fractions of nanocomposite from the rule of mixture which were given as input to FEA, as shown in Table III. The elastic modulus of FGM and density were obtained at different volume fractions of nanocomposite from experiments (tensile test).

TABLE III: Poisson's ratio for each layer of FGM

Vf. Particles %	Poisson's ratio (rule of mixture)
0	0.33
1	0.3285
2	0.327
3	0.3255
4	0.324

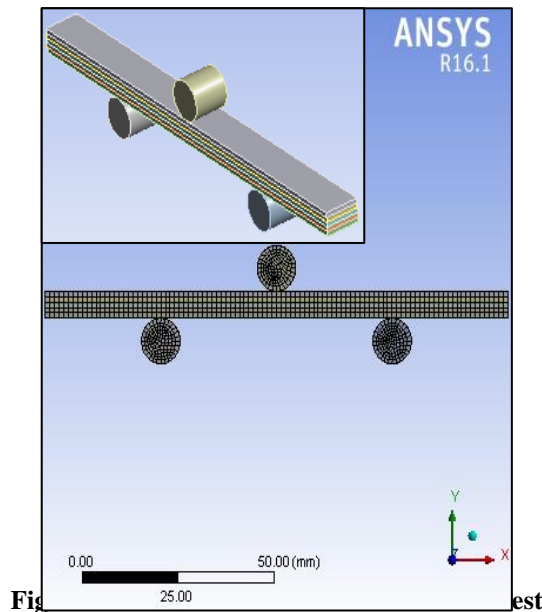

Fig. 1. Finite element analysis model of the nanocomposite beam.

5. RESULTS AND DISCUSSION

5.1. The influence of filler loading upon the nanocomposite fraction of void

The content of void in a nanocomposite material can be accessed via the comparison of the theoretical density with its real density. Table IV lists the theoretical and experimentally measured densities of the neat epoxy, the consistent Al_2O_3 nanocomposites, and the FGMs with the matching fraction of void.

Also, Table IV shows the effect of the ($V_f\%$) of alumina nanocomposite upon the experimentally measured density of the epoxy composites. The alumina incorporation raised the epoxy matrix density, confirming the nanofillers advantage as a particulate reinforcement. The epoxy-based composite density was found increased with the increment in nanoparticle loading. It's obvious from Table IV that the experimentally measured density and the percentage of epoxy void raise with the nanoparticles incorporation.

One can see obviously from Table IV that the particles FGMs have lower density than their relevant monolithic nanocomposites possessing nanoparticles with (2% V_f). Therefore, one can say that for a known sample size, the gradation in the particles concentration can lower the functionally graded polymer nanocomposite weight in comparison with that of the monolithic nanocomposites.

TABLE IV: Theoretical, experimental density and void fraction for different volume fractions

Composites	Theoretical density g/cm^3	Experimental density g/cm^3	Void fraction %
Epoxy	1.15	1.145	0.436
1% Al_2O_3	1.171	1.164	1.058
2% Al_2O_3	1.191	1.168	1.769
3% Al_2O_3	1.211	1.187	2.564
4% Al_2O_3	1.232	1.191	3.529
FGM1	1.191	1.146	3.926
FGM2	1.191	1.161	2.672
FGM3	1.191	1.148	3.745

5.2. Tensile and compression test results and discussion

Figures 6 and 7 elucidate the Stress-Strain curve of the neat epoxy and the epoxy/ Al_2O_3 nanocomposite with different volume fractions under tensile and compressive load respectively. Adding the stiff particles to a matrix of polymer can simply enhance its stiffness, since the inorganic fillers rigidity is in general much higher than that for the organic polymers. Young's modulus is markedly improved by adding nanoparticles to a polymer matrix. Nanoparticles give higher rigidity to the polymers [18]. The slope of the first linear region of curve was utilized for determining the Young's elastic of specimens. The raised nonlinearity in the Stress-Strain curve is a sign of the bigger plastic zone. The lower slope depicts the less composites stiffness. Tensile and compressive strength of the neat epoxy and the epoxy- Al_2O_3 nanocomposites being computed via getting the ratio of the ultimate load got via the specimen and the initial area of the cross-section within the specimen gauge region.

As observed from the compressive strength values shown in figure 8, they are greater than the tensile strength value revealed in figure 5. Brittle materials such as polymer composite are recognized by the fact that their compressive strength value is more than their tensile strength value.

Figures 6 and 7 were plotted for the epoxy/ Al_2O_3 nanocomposites with various Al_2O_3 volume fractions for tensile and compression, respectively. Results revealed that the Al_2O_3 nanoparticles are effective to enhance the modulus of elasticity, and the ultimate tensile strength as compared with the epoxy resin. At (4% Vf.) of nanoparticles, an increment of (51.5%) in the elastic modulus and the UTS increased up to (72) were registered above those for the neat epoxy. The stiff Al_2O_3 nanoparticles limit the local matrix deformation beneath the exerted load resulting improvement in the nanocomposites stiffness.

This indicates greater tensile toughness compared to the neat epoxy. The raised nanocomposite tensile strength is owing to the superior interfacial interaction between the nanoparticles and the matrix resulting better transfer of stress in composites. Due to the interface between the nano-particles and matrix (imperfect bonding), the stress concentration and the void content effects may reduce the UTS after the threshold level, so the interfacial de-bonding between the nanoparticles and the matrix has to be considered during the modelling.

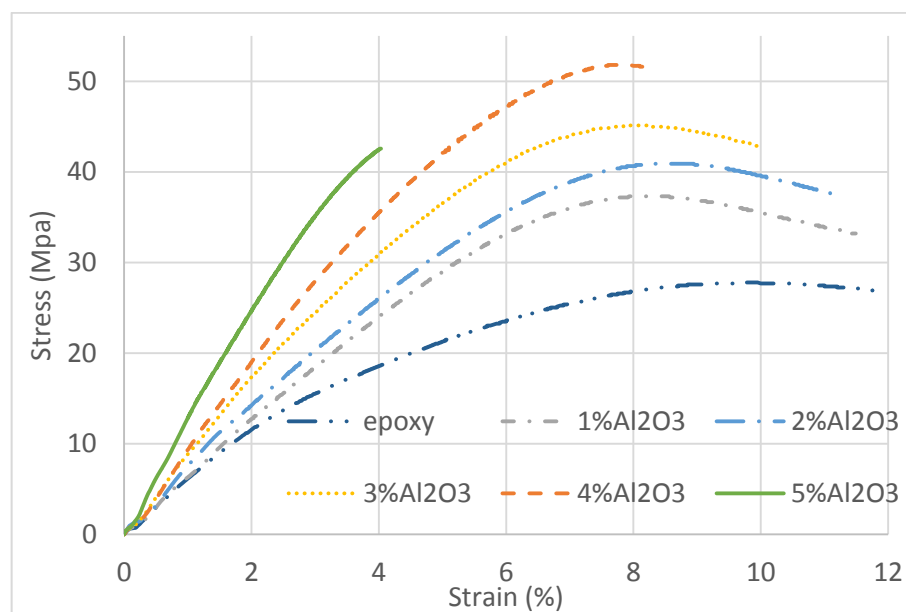

Figure 6: Tensile behavior of epoxy/ Al_2O_3 nanocomposite

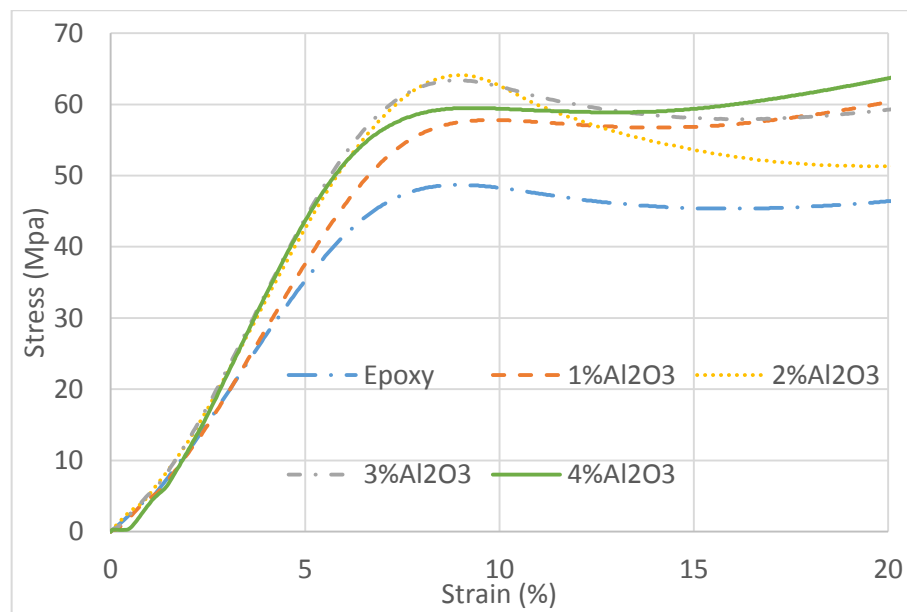

Figure 7: Compression behavior of epoxy/Al₂O₃ nanocomposite

The compression strength values increased rapidly after the addition of nano Al₂O₃, and its maximum amount was at (2% V_p) which is increased by (31.4%) from the pristine epoxy. When the concentration of Al₂O₃ was increased, the compressive strength values decreased rapidly but they were still greater than those of the epoxy neat. The strength vigorously relies upon the transfer of stress between the matrix and the particles. Thus, the layered functionally graded material having a thickness of (6 mm) was done with layers having a thickness of (1.2 mm) via changing the percentage of Vf. from zero (neat epoxy) to (4) with (1% Vf.) step to perform the gradation in strength and modulus along the FGM thickness. The Young's modulus calculated for each layer from tensile test was used in the finite element analysis to compare the flexural properties of experimental work (Figure 8).

The operative stress transfer is the highly significant factor contributing to the strength of the two-phase composite materials. To the weakly bonded particles, the transmission of stress at the particle/polymer interface isn't efficient. The discontinuity in the debonding form occurs due to the particle non-adherence to the polymer. Therefore, the particle is not able to convey any load, and the composite strength reduces by rising the burdening of particle. Nevertheless, for the composites comprising well-bonded particles, the particles addition to a polymer shall head to a strength increment, particularly for the nanoparticles having high surface areas [19].

Those agglomerates become impurities and cause a failure source. When the concentration increases, the number of particles will increase, and that causes a particle-particle interaction instead of the particle-matrix interaction. Consequently, the particles start agglomerating and forming lumps that finally influence the interaction of Van der Waals among the chains of polymer and that may lead to a reduction in the strength properties [14].

Therefore, the layered (FGM) having a thickness of (6 mm) was prepared with the (1.2 mm) thickness layers via changing the Vf. % from 0 (neat epoxy) to 2 with a (0.5) step in Vf.% to perform the gradation in the modulus and strength along the (FGM) thickness. The Young's modulus was calculated for every layer from the tensile test in the finite element analysis to compare the flexural properties with the experimental work (Figure 9).

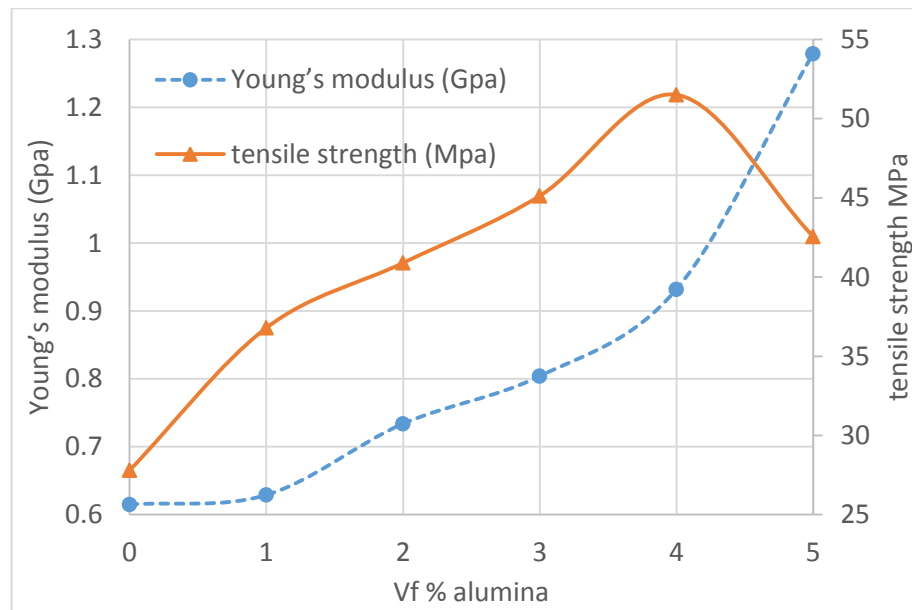

Figure 8: Effect of alumina nanoparticles on Young's modulus and ultimate tensile strength

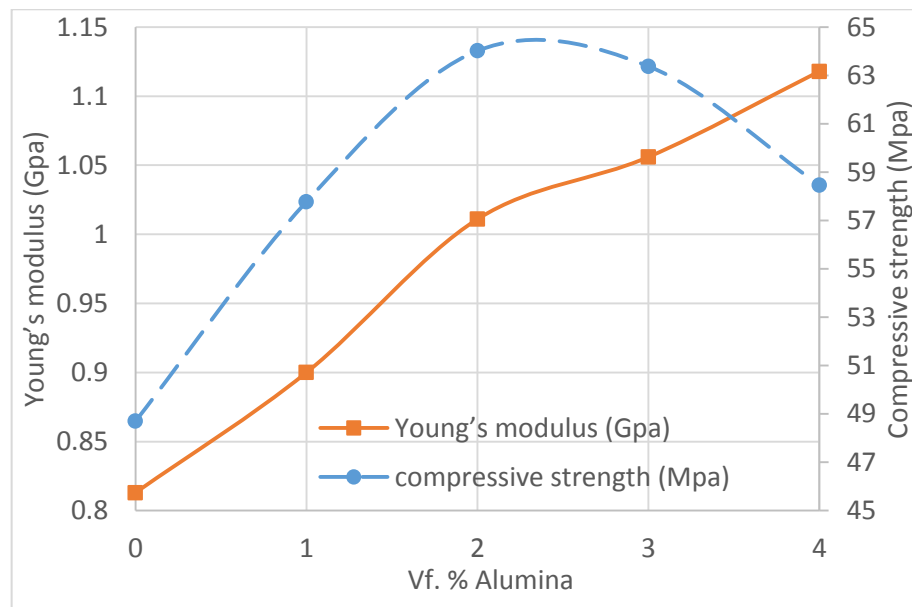

Figure 9: Effect of alumina nanoparticles Vf. % on compression strength and Young's modulus

5.3. Flexural test results

The obtained load-displacement curves from the 3-point bending test of the neat epoxy (layered), the isotropic nanocomposites (layered) and the FGMs specimens are illustrated in the figure 8. Then, these were changed to stress-strain diagram by using equations (5) to (7). The failure of the functionally graded polymer nanocomposite in the flexural mode was controlled via the propagation of crack. The whole fracture of samples occurred owing to the crack propagation from the tensile side to the compression side. The samples were broken from the mid, and the delamination wasn't noticed, revealing an appropriate bonding between the layers.

The comparison of the Young's modulus and the flexural strength for epoxy, nanocomposite isotropic and FGMs nano Al_2O_3 is demonstrated in Figure 10. The results indicated an improvement of (67%) in the flexural modulus and (51.7%) in the flexural strength of the functionally graded polymer nanocomposite above those for the layered samples of the neat epoxy if loaded from the side of neat

epoxy owing to the lowest layer; that means a composite layer having a high Young's modulus's compared to pure epoxy. It was observed that the flexural strength and Young's modulus for the non-graded nanocomposites were higher than pure epoxy, due to the presence of nanoparticles, while an enhancement of (29.4%) in the flexural modulus and (17.8%) in the flexural strength was noted above those for the layered samples of epoxy if loaded from the side of composite. In such state, the lowest layer of pure epoxy has the lowest flexural modulus and flexural strength and modulus that resulting a decrease in the graded nanocomposites modulus and strength.

In flexural test, the layer, at which the load is exerted, undergoes a compressive stress, where the layers at the opposing side shall be beneath the tensile stress. In different words, in 3-point bending, the layers underneath the neutral axis shall undergo tensile stresses, where the layers over the neutral axis (towards the side of loading) shall undergo compressive stresses. With the aid of the Young's modulus and the density of the nanocomposites individual layers, the neutral axis position of layered functionally graded polymer nanocomposite was obtained and was found to be located nearly at the middle plane of the layered composite in the direction of thickness. Therefore, the gradation didn't move the neutral axis position considerably from the axis of centroid owing to the truth that the change in the nanocomposites density for the various nanoparticles concentrations being too slight.

The crack propagation that started in the layer beneath the tensile stresses shall be simpler than that in the layer beneath the compressive stresses. Therefore, the stiffer and the vigorous layers in the zone of tensile stress in the 3-point bending test will participate more in improving the flexural characteristic of the functionally graded polymer nanocomposite. Therefore, for a 3-point bending test, the outer layer; that means the layer opposing to the exerted load surface takes a significant role in the increase of the flexural characteristic of the functionally graded polymer nanocomposites. The layered functionally graded polymer nanocomposite possessing a stiffer and vigorous outer layer shall have better flexural characteristic.

The results obtained from the ANSYS program are portrayed in Figure 11, where similar loads are applied to the loads applied in practice and then compared to the resulting deflection with practical deflection. The Poisson's ratio, density and Young's modulus for each layer were calculated from the experimental work. A good agreement was obtained between FEA and experimental work.

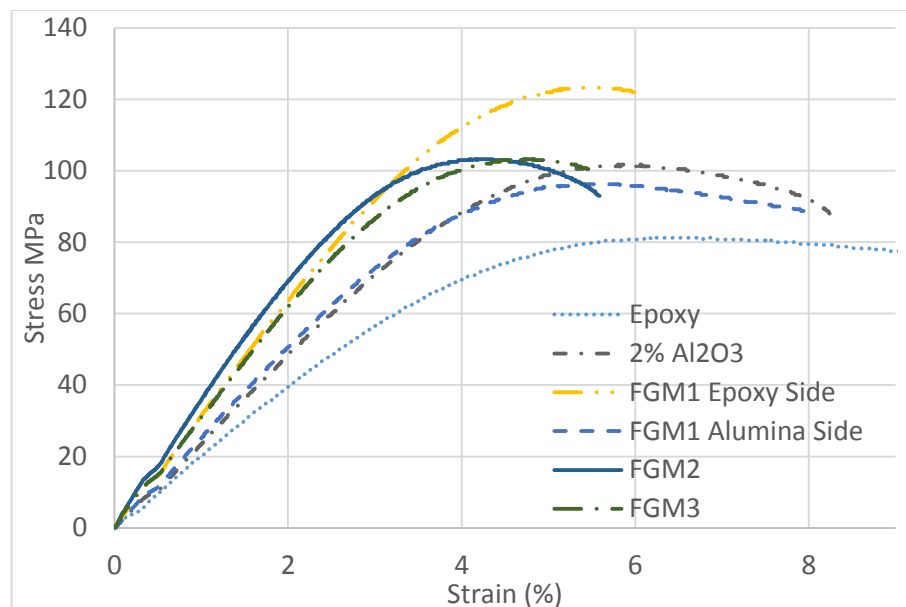

Figure 10: Flexural stress strain diagram for alumina nanocomposite

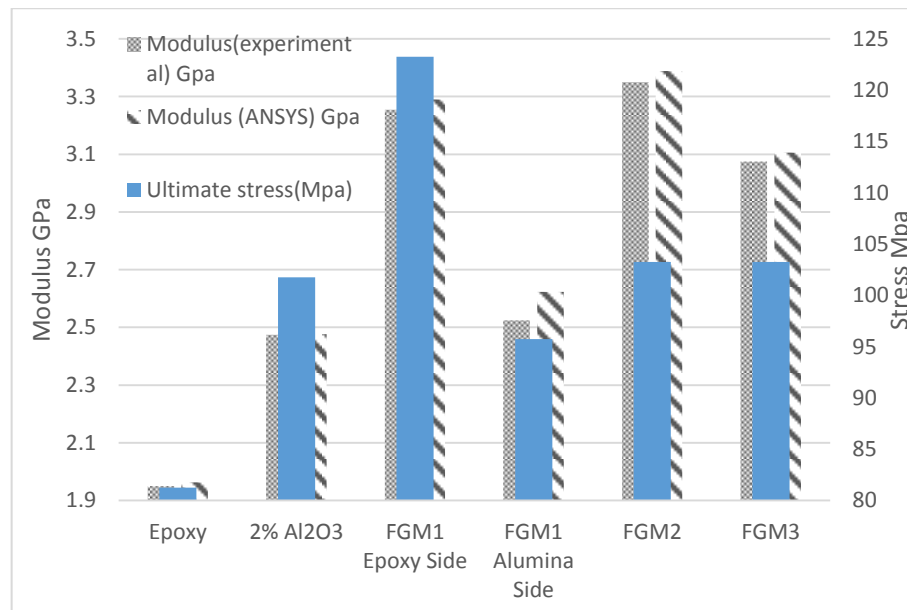

Figure 11: Flexural strength and Young's Modulus for epoxy, isotropic and FGMs nano alumina

6. CONCLUSIONS

The following points can be concluded from this study:

- 1) Tensile strength and Young's modulus of the non-graded nanocomposites increase with the increased volume fraction of nanoparticles; the highest value was at (4% Vf.) for strength and increased for Young's modulus.
- 2) For compressive strength, the ultimate strength was increased until reached the threshold value (2% Vf.), and the Young's modulus remains increased.
- 3) The Al₂O₃ nanoparticles reinforcement and gradation in the layered shape can be a remarkable attracting method for improving the flexural characteristics of the functionally graded polymer nanocomposite (FGPNC).
- 4) Flexural modulus and strength are highly influenced via the exerted load direction for FGM1.
- 5) The results manifested that the flexural strength and Young's modulus loaded from the pure epoxy side was higher than when samples loaded from the composites side for FGM1.
- 6) A good agreement was found between the experimental and the finite element analysis using ANSYS software for flexural analysis, which means no delamination between the layers of FGMs samples and a good fabrication of the FGMs samples.

References

- [1] V. Bhavar, P. Kattire, S. Thakare, S. Patil, and R. Singh, "A review on functionally gradient materials (FGMS) and their applications," Iop Conf. Series: Materials Science and Engineering, Thailand, 2017, 229.
- [2] Y. Wang, Q. Q. Ni, Y. Zhu, and T. Natsuki, "Fabrication of functionally graded nano-Tio₂-reinforced epoxy matrix composites," Polymer Composites, Vol. 35, No. 3, PP. 557-563, 2014.
- [3] A. A. Al-Ameery, Z. F. Al-Bawi, and W. A. Hanna, "Study of the effect of alumina nano particles addition on some mechanical and physical properties of an epoxy resin polymer matrix composite," Jkau: Eng. Sci., Vol. 24, No. 1, PP. 23-44, 2013.
- [4] I. Al-Namie, A. A. Ibrahim, and M. F. Hassan, "Study the mechanical properties of epoxy resin reinforced with silica (quartz) and alumina particles," The Iraqi Journal for Mechanical and Material Engineering, Vol.11, No.3, PP. 486-506, 2011.

- [5] S. K. Mishra, D. K. Shukla, and R. K. Patel, "flexural properties of functionally graded epoxy-alumina polymer nanocomposite," *Materials Today: Proceedings*, Vol. 5, No.2, PP. 8431–8435, 2018.
- [6] P. Tsotra, and K. Friedrich, "Electrical and mechanical properties of functionally graded epoxy-resin/carbon fiber composites," *Composites Part an Applied Science and Manufacturing*, Vol. 34, No. 1, PP. 75-82, 2003.
- [7] B. Holm, R. Ahuja, Y. Yourdshahyan, B. Johansson, and B. I. Lundqvist, "elastic and optical properties of A-and K-Al₂O₃," *Physical Review*, Vol. 59, No.3, PP. 12777–12787, 1999.
- [8] S. Zhao, L. S. Schadler, R. Duncan, H. Hillsboro, and T.Auletta, "mechanisms leading to improved mechanical performance in nanoscale alumina filled epoxy," *Composites Science and Technology*, Vol. 68, No. 14, PP. 2965–2975, 2008.
- [9] V. Parameswaran, and A. Shukla, "asymptotic stress fields for stationary cracks along the gradient in functionally graded materials," *J Appl Mech*, Vol. 69, PP. 240–243, 2002.
- [10] R. Kommana, and V. Parameswaran, "Experimental and numerical investigation of a cracked transversely graded plate subjected to in plane bending," *Int J Solids Struct*, Vol. 46, No.11, PP. 2420–2428, 2009.
- [11] U. Jagan, P. S. Chauhan, and V. Parameswaran, "energy release rate for interlaminar cracks in graded laminates," *Compos Sci Technol*, Vol. 68, No.6, PP. 1480–1488, 2008.
- [12] A. Carpinteri, M. Paggi, and N. Pugno, "An analytical approach for fracture and fatigue in functionally graded materials," *Int J Fract*, Vol. 141, No.3, PP. 535–547, 2006.
- [13] V. Parameswaran, and A. Shukla, "Crack-tip stress fields for dynamic fracture in functionally gradient materials," *Mech Mater*, Vol. 31, No.9, PP. 579–596, 1991.
- [14] S. K. Mishra, D. K. Shukla, and R. K. Patela, "Effect of particle morphology on flexural properties of functionally graded epoxy-alumina polymer nanocomposite," *Materials Research Express*, Vol. 6, No. 12, PP. 1-32, 2020.
- [15] ASTM D638, "standard test method for tensile properties of plastics," *Annual Book of ASTM Standards*, American Society of Testing and Materials, West Conshohocken, 2014.
- [16] ASTM D790 "Standard test methods for flexural properties of unreinforced and reinforced plastics and electrical insulating materials," *ASTM International*, West Conshohocken, Pa, United States, 2014.
- [17] W. D. Callister, and D. G. Rethwisch, "Materials science and engineering," *John Wiley & Sons, Inc.*, 10th Edition, New York 2018.
- [18] S. Fu, X. Feng, B. Lauke, and Y. Mai, , "Effects of particle size, article/matrix interface adhesion and particle loading," *Composites Part B: Engineering*, Vol. 39, No.6, pp 933-961, 2008.
- [19] A. Chatterjee and M. S. Islam, "Fabrication and characterization of TiO₂-epoxy nanocomposite," *Matr. Sci. and Eng.*, Vol. 487, No.1, pp 574–585, 2008.