



Signaling Load Reduction in 5G Network and Beyond

Mohammed A. Waheed^{a,*}, Azzad B. Saeed^b, Thanaa H. Abd^c

^{a,b} Electrical Engineering Dept., University of Technology-Iraq, Alsina'a street, 10066 Baghdad, Iraq.

^c Ministry of Science and Technology, Space and Telecommunications Directorate, Baghdad, Iraq.

*Corresponding author Email: eee.19.19@grad.uotechnology.edu.iq

HIGHLIGHTS

- The number of messages has been reduced in the proposed architecture as compared with the previous related works.
- The signaling load in the Long Term Evolution was reduced by 45.4% when taking into consideration the area size.
- The signaling load in the Long Term Evolution was reduced by 38.3% when analyzing the User Equipment velocity.
- The signaling load in the Long Term Evolution was reduced by 46.04% when taking into consideration the User Equipment number.

ABSTRACT

A huge traffic flow in the next generation network is anticipated due to the rising in number of users and the new services that need low end-to-end latency causing a large signaling load on the Core Network (CN). In order to mitigate this issue, many revolutionary architectures have been proposed to reduce this burden such as Cloud Radio Access Network (C-RAN). In this paper, a new C-RAN distributed core network architecture has been proposed by splitting some CN functions and grouping them into one location with Base Band Units (BBUs). As a measure of testing the proposed architectures and by using the MATLAB, the number of signaling messages processed by the control entities was analyzed. The evaluation results indicate a significant improvement if it have been compared to Long Term Evolution (LTE) architecture in terms of signaling load reduction, As the average signaling load was reduced by 46.04 percent in one of the proposed architectures when the number of user equipments increased.

ARTICLE INFO

Handling editor: Ivan A. Hashim

Keywords:

C-RAN
SDN
Virtualization
Long Term Evolution
5G

1. Introduction

The introduction of various mobile multimedia services like the ultra-high-definition video, augmented and virtual realities, is increasing the demand for services for mobile networks [1-3]. Consequently, the requirements for network ability and service quality are rising exponentially [4]. The current Long-Term Evolution (LTE) architecture lacks flexibility to accommodate this increase in data request rates. Therefore, as a solution to increase network capacity, operators are inserting more cells [5], this action leads to increased inter-cell interference levels, more handovers, and significant expenses [6]. All of this led to the formation of the Fifth Generation (5G) network that is due to start in 2021, in order to solve the existing network capacity issue [7]. 5G supports a range of technologies, such as machine and device applications, internet of things, vehicle to anything and Bluetooth [8-12]. Such applications would have an effect on industry, society and consumer interactions [13-16]. However, the high data rate requires very broad bandwidth to meet and fulfill User Equipments (UEs) satisfaction. For a 5G system, a bandwidth of 10 times as much as is needed for the 4G system is required [17]. Cloud Radio Access Network (C-RAN) is one of 5G cell network solutions and an accessible architecture. By leveraging virtualization technology, C-RAN splits the conventional base stations into centralized BaseBand Unit (BBU) pool and multiple low power Remote Radio Heads (RRHs), which can offer high data rates with energy efficiency [18-24]. The RRH forwards user data to BBU pool via fronthaul links. Despite the benefits of the C-RAN architecture, the signaling load issue on the Core Network (CN) entities had not been addressed. Because of the increasing demand for data and the huge connection between the BBU pools and the CN, this will need super processing capacity the CN or Evolved Packet Core (EPC) cannot bear it. The EPC architecture is struggling, since

the control plane remains closely linked to the Serving GateWay (SGW) and Packet Data Network (PDN) GateWay (PGW) data plane, which leads to a lot of control signals between the EPC components. Nowadays, there is a new paradigm of communication networking called software-defined networking (SDN) [25]. Using this architecture, it is possible to separate the data plane from the control plane in network entities and make their roles more clear. This paper therefore introduces a new approach based on SDN and C-RAN that, as well as distributing and moving the control elements of the core network, aligns these with the BBU in order to achieve the lowest level of load possible on the core network.

In the last few years, due to the heavy signaling load on the CN, several researchers have tried to minimize this load. In 2020, R. Shah *et al.*, suggest a refactoring of the mobile core in order to speed up and get the control plane closer to the end user [26], the proposed architecture improved control plane throughput and reduced the control plane latency. In 2018 and 2017, J. Cho *et al.* and Z. A. Qazi *et al.* respectively refactor the core network control plane to reduce the overhead of state transfer across modules and maximize control and scalability of the plane [27, 28]. Distributed network is crucial to reducing the work load on the entities and improving the efficiency of the system [29, 30]. Based on the above, in 2012, X. An, F. Pianese *et al.* have adopted the distribution of Mobility Management Entity (MME) on the basis of segregation between the planes of control and user [31], they apply three scenarios the edge deployment, local deployment and regional deployment. This analysis has shown an increase in the overall decrease in signaling latency, this leading to primarily estimate the signaling delay by the number of signals swapped across network links. In 2016, M. Pozza have proposed a segregation between the planes of control and user in entities of the LTE architecture and use that with the SDN and virtualization [32]. This approach also has shown an improvement in the signaling latency. In 2013 and 2014, S. B. H. Said *et al.* and M. R. Sama *et al.* respectively have adopted a partial segregation between the planes of control and user at the SGW [33, 34]. This method is creative which has shown an increase in the overall reduction of messaging burden. However, this design is Incomplete solution because the PGW is still functionally follows the existing 3rd Generation Partnership Project (3GPP) architecture. A method that complements the previous concept has been suggested by V. G. Nguyen *et al.* In 2015 [35], It is based on complete separation of all CN entities including PGW as they are separated and virtualized as an application operate over an OpenFlow (OF) controller. This approach is focused on complete segregation between the planes of control and user. However, the suggested architectures in all the works above are done as Distributed Radio Access Network (D-RAN). However, in 2016, I. Al-Samman *et al.* have proposed the deployment of the MMEs in one pool with the Base Band Unit (BBU) pool [36, 37]. The overall reduction of the signaling load has been increased by this approach.

In this paper, two proposals were presented to reduce the load on the CN, which are the Partially Distributed Core Network (PDCN) and the Fully Distributed Core Network (FDCN). The C-RAN architecture was adopted, in addition to separating and distributing control entities making use of the SDN paradigm. The aim is to find a better signaling load architecture. The remainder of the document is structured accordingly. Section 2 explains the research method. The results and discussions are given in Section 3. Finally, the conclusion is given in Section 4.

2. Research Method

2.1 Proposed architecture 1

In this section, to reduce the load on the CN, the research method has been presented, which includes, as a first step, separating the data plane from the control plane of the CN entities (SGW and PGW). After that, the control entities were functionally combined into a single controller called the BBU Controller (BBUC), which was migrated and combined with the BBU in one pool. In this context, each C-RAN is a group of BBU in addition to the BBUC in one pool. C-RAN consists of several number of Remote Radio Heads (RRHs). Figure 1 depicts the architecture of PDCN. In this architecture, the data plane has been separated from the control plane of the SGW only. SGW Control plane (SGW-C) and MME have been realized as an application running on BBUC while keeping the SGW User plane (SGW-U) and PGW in the CN.

The first step for a UE to log into the network after it is enabled is initial attachment procedure. In this process, the IP address for future data transfers is assigned for the UE through the BBUC. After UE sends an attachment request message, the call flow starts as shown in Figure 2 for the initial attachment. The load for this event is indicated by:

$$LPI(n) = 5 \cdot Po \cdot \rho \cdot A \cdot C \quad (1)$$

where: Po : is the possibility that the UE will start a network attachment process.

A : is the cell area.

ρ : is the density of UE (no. of UEs/ km²).

C : The overall RRH number in an area under analysis.

The second event analyzed in this paper is the Idle to an Active (I to A) and Active to Idle (A to I) transition. The idle to an active transition process happens as the UE in a inactive status wants to utilize the internet service or the PDN networks and vice versa for active to idle transition as shown in Figure 3. Similarly, the signaling load has been caused by the active to idle transition and idle to active transition is given as:

$$LPA2I(n) = 2 \cdot \lambda n \cdot P \cdot \rho \cdot A \cdot C \quad (2)$$

where: P : is the possibility of a UE to create type-n session.

λn : The type-n sessions' middling access rate for each UE.

The third procedure is network-triggered service, if the network has a downlink traffic required to deliver to a UE in the idle state, the network-activated service request is executed. The network has no idea where the idle-state UE was located.

Consequently, the network must first perform the paging procedures in order to notify the new traffic to the UE, the UE is starting the service request process upon reception the paging signal from the network. At the end of a service request procedure, the UE state from Idle to active state is specified. The signaling load has been caused by this event is given as:

$$LP_{tri}(n) = ((3 + CBBU)Rp \cdot PI + 2(1 - PI)) \cdot \lambda n \cdot (1 - P) \cdot \rho \cdot A \cdot C \tag{3}$$

where: Rp : is the average amount of paging for each delivery.

$CBBU$: CBBU is the number of BBU pools In the region under analysis.

PI : is the possibility of a UE being in inactive mode.

The possibility that the UE in active mode is $(1 - PI)$ has been demonstrated in the reference document [38].

The fourth procedure to analyze is the handover. This procedure shows how a data transmission path can be restored for user data traffic so that the data session can be maintained when the UE moves between the base stations. Based on the UE's movement, there are two types of handovers: the inner handover (occur between the BBUs inside the pool) and outer handover (occur between the BBU pools). From Figure 4 it can be noted that there are 3 messages are traded, therefore the signaling load has been caused by the inner handover is given as follows:

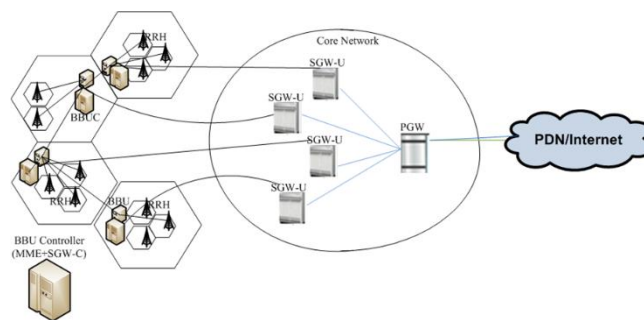

Figure 1: Proposed architecture 1 (Partially Distributed Core Network (PDCN))

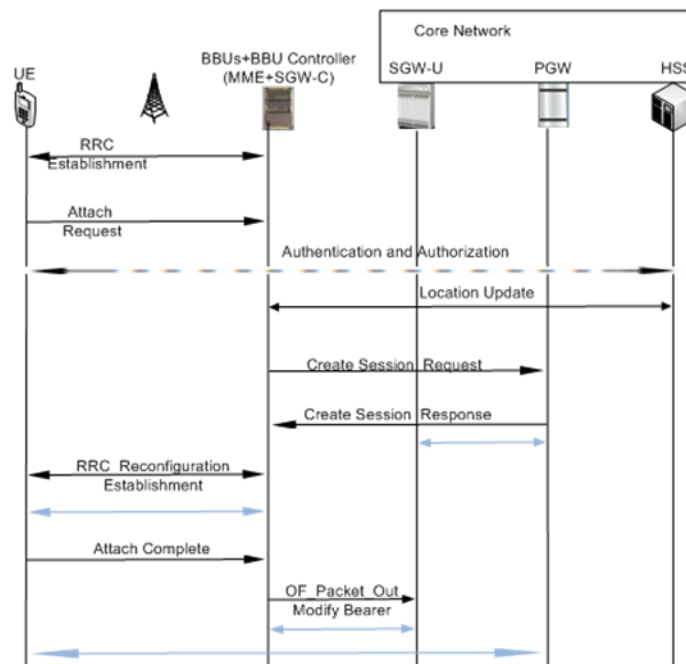

Figure 2: Procedure for the initial attachment in PDCN architecture

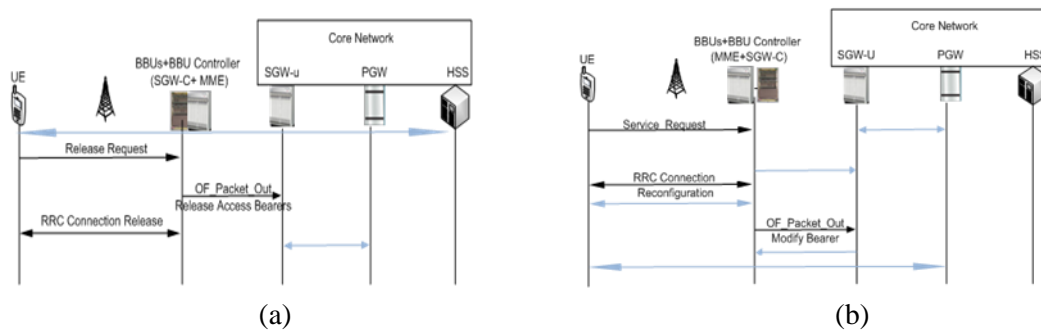

Figure 3: a. Procedure for the active to idle transition
 b. Procedure for the idle to active transition

$$LPinh(n) = 3 . Rc . (1 - PI) . C \tag{4}$$

where: Rc : is the crossover rate from a closed area of a group of UEs ($Rc = (\rho LV)/\pi$) [38].

Likewise and as shown in Figure 5, the signaling load has been caused by the outer handover is given as follows:

$$LPouth(n) = 8 . RBBU (1 - PI) . CBBU \tag{5}$$

The final procedure is Tracking Area Update (TAU). The TAU event occurs if a UE reaches a new tracking area that is not included in the database of identifiers for the tracking area assigned by the network. The UE is going to update its current monitoring area to the network regardless of whether it's a connected state or an idle. Figure 6 depicts the tracking area update procedure for the PDCN architecture. The latest UE location will be updated at the end of this procedure. The maximum number of signals handled by BBUC is 8 and the total signal load is as follows:

$$LPtau(n) = \frac{8}{\sqrt{CBBUU}} . C . Rc \tag{6}$$

The total signaling load in the five events is the sum of the equations (1, 2, 3, 4, 5 and 6).

2.1 Proposed architecture 2

The second proposed architecture is similar to the first in terms of the C-RAN architecture and the SDN paradigm. However, in this architecture the PGW control plane (PGW-C) was separated and distributed rather than kept central to the CN. Figure 7 depicts the FDCN architecture. In this framework, a SGW-C, PGW-C and an MME were achieved as an application running on the top of the BBUC. SGW-U and PGW User plane (PGW-U) are not migrated but are kept in the CN

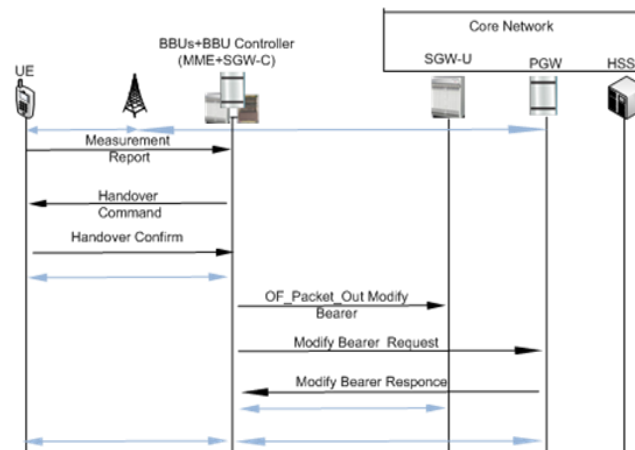

Figure 4: Procedure for the inner handover in PDCN architecture

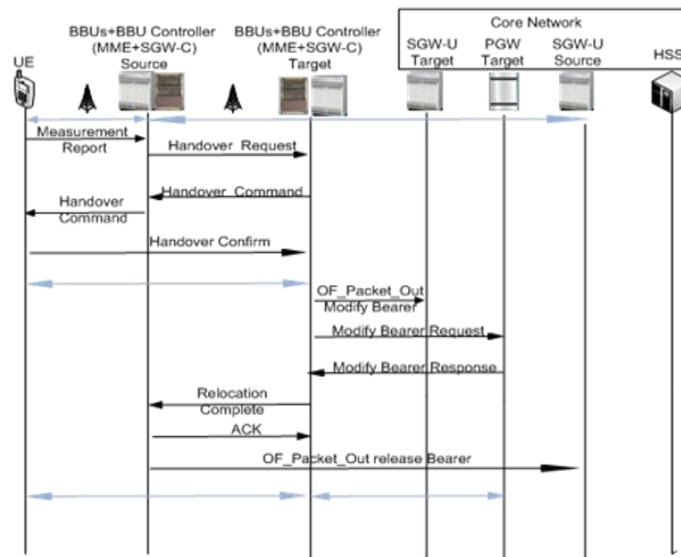

Figure 5: Procedure for the outer handover in PDCN architecture

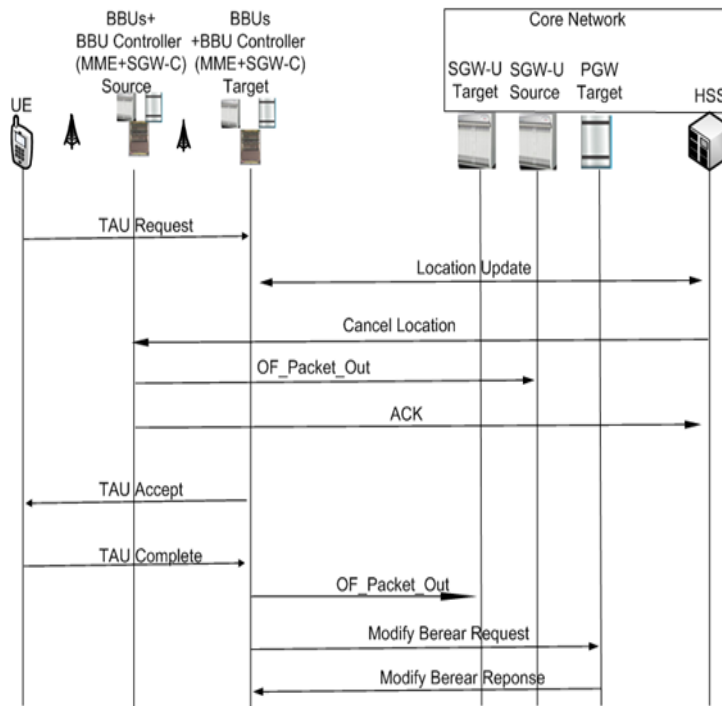

Figure 6: Procedure for the tracking area update in PDCN architecture

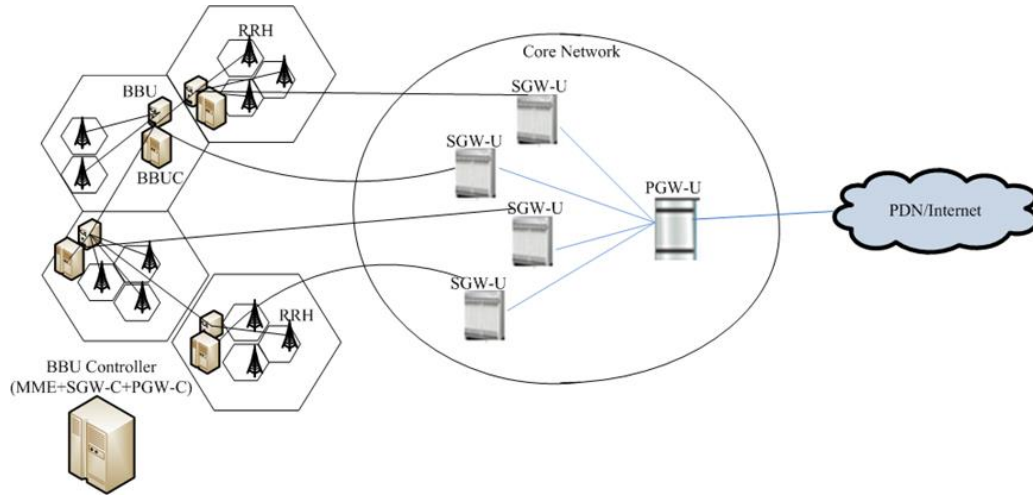

Figure 7: Proposed architecture 2 (Fully Distributed Core Network (FDCN))

This section has only highlighted signalling load calculations, as the key functions are already clarified. Depending on Figure 8, the signalling load from the initial attachment procedure is calculated by:

$$LFI(n) = 4 P o \rho A C \tag{7}$$

Similarly, The signaling burden induced by the active to idle and idle to active transition is given as:

$$LFA2I(n) = 2 \lambda n P \rho A C \tag{8}$$

In the situation of the service request triggered by the network, in addition to paging messages while UE is in the inactive state, a paging case requires 3 messages from the BBUC. Paging is not necessary when the UE in active state and the message count will be 2. The signaling load caused by this event is given as:

$$LFtri(n) = ((3 + CBBU) R p PI + 2 (1 - PI)) \lambda n (1 - P) \rho C A \tag{9}$$

From Figure 9 and Figure 10, the signalling load resulting from the inner and outer handover procedure is given in Equation 4 and 5, respectively.

$$LFinh(n) = R c (1 - PI) C \tag{10}$$

$$LFouth(n) = 5 R BBU (1 - PI) C BBU \tag{11}$$

Where: Rc : is the rate of crossing from a closed region of a set of UEs ($Rc = (\rho L V)/\pi$) [38].

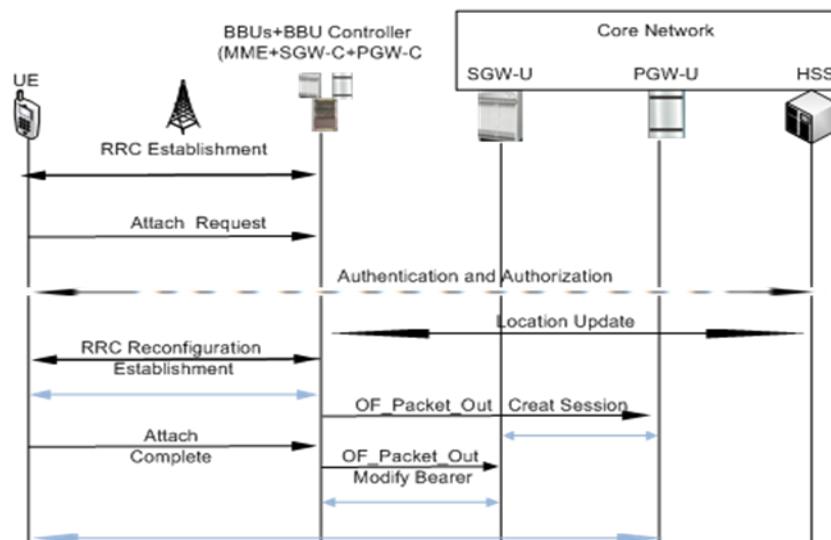

Figure 8: Procedure for the initial attachment in FDCN architecture

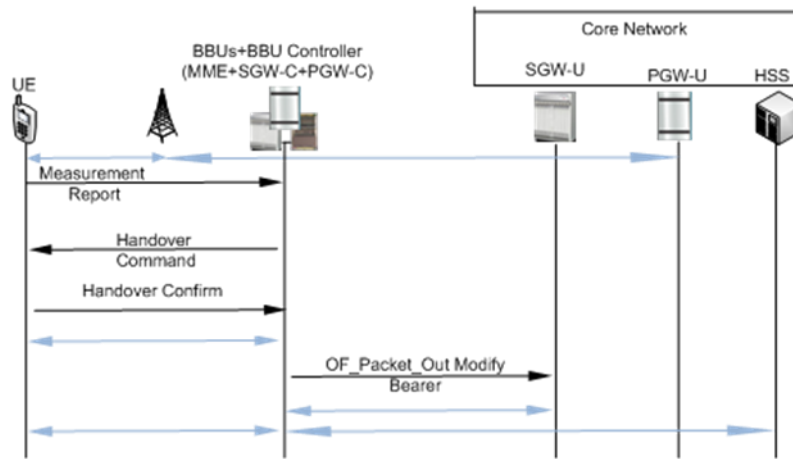

Figure 9: Procedure for the inner handover in FDCN architecture

From Figure 11, the signaling load caused by the TAU event is given as:

$$LF_{tau}(n) = (7/\sqrt{CBBU}) R_c C \tag{12}$$

In conclusion, the total signaling load in the five events is the sum of the equations (7, 8, 9, 10, 11 and 12).

3. Results and Discussions

In this section, the numerical outcomes related to the signaling load have been presented for the PDCN, FDCN, traditional LTE which was explained in detail in [35, 38], Full Openflow-enabled EPC (OEPC) proposed by V. G. Nguyen *et al.* [35] in 2015 and the C-RAN.DMME architecture proposed by I. Al-Samman *et al.* [36] in 2016. The scenario's default values are $\lambda n = 0.05$, the average session duration of 0.2, $R_p = 1.1$ number of RRHs, BBUs equal to 500 and 5 respectively and the number of users equal to one million. Assuming a uniform hexagonal cell with an overlap factor γ equal to 1.2, the requisite cell radius to cover the total area is [36]:

$$r = \gamma \sqrt{\frac{2 ST}{3 \sqrt{3} c}} \tag{13}$$

In terms of the number of messages exchanged between control entities for each event, Table 1. shows a comparison between the proposed architectures and traditional LTE architecture, in this table, assuming that there is no SGW relocation in X2 and S1 handovers. It is obvious that with the exception of TAU, there is far less control messages in the proposed architectures than traditional architecture.

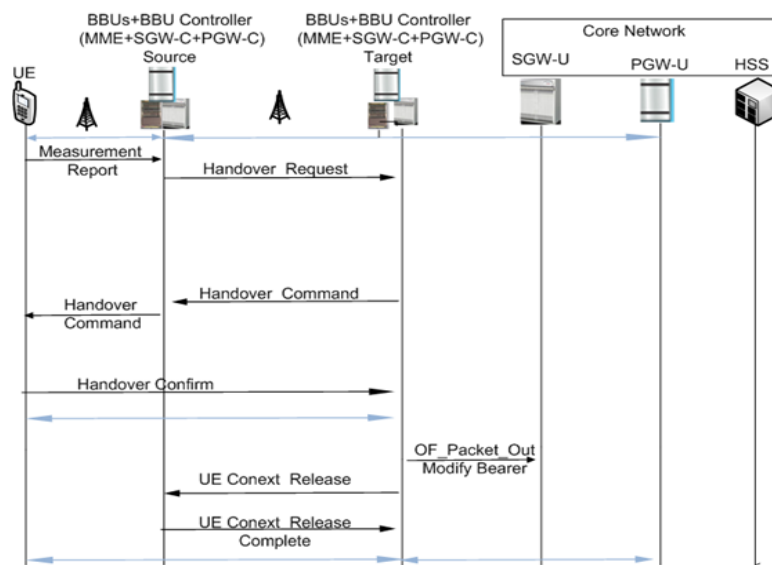

Figure 10: Procedure for the outer handover in FDCN architecture

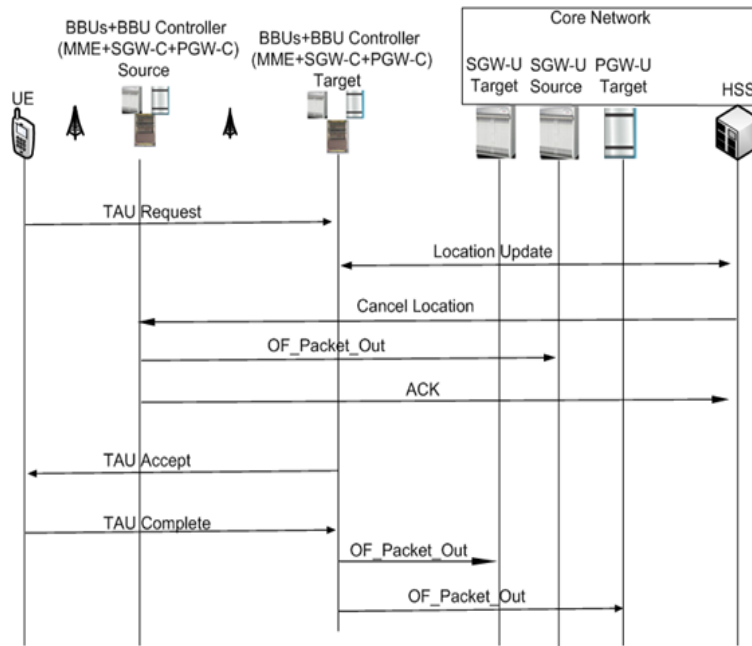

Figure 11: Procedure for the tracking area update in FDCN architecture

In the first evaluation, the region's area has been increased and the amount of signaling messages handled by MME and the controller are calculated. The total signaling load differences among all previously considered architectures, are shown in Figure 12. It is evident to note that the proposed architectures experiences the lowest load level followed by C-RAN.DMM. Full OEPC architecture however demonstrates better efficiency than traditional LTE architecture. This is due to the reduction in the number of exchanged messages in LTE architecture between MME, PGW and SGW. In Table 2, up to 2.412×10^7 message/hour and 3.0337×10^7 message/hour of the average signaling load relative to LTE architecture can be reduced with the implementation of the PDCN and FDCN architectures respectively. As compared with traditional architecture, C-RAN.D-MME and Full OEPC reduce 1.2579×10^7 message/hour and 0.3346×10^7 message/hour respectively on average signaling load.

The changing velocity of the user is another metric to analyze. It is logical that raising the velocity increases the overall signaling loads as the handover and the tracking area update will frequently occur irrespective of the architecture implemented. As shown in Figure 13, the velocity of the UE varies between 0 and 120 km/h. The figure shows that, followed by C-RAN.D-MME and the Full OEPC, the proposed architectures results in the least signaling load. Whereas, as shown in Table 2, the average signaling load decreased by 1.4554×10^7 message/hour and 2.2584×10^7 message/hour in the PDCN and FDCN architectures, respectively, relative to the existing LTE architecture.

For the third case, The impact of the number of users on the overall signaling load in the proposed architecture, CRAN.DMME, Full OEPC and traditional architecture have been examined. As shown in Figure 14, when the number of network users is increased from 0 to 1000, the signaling load increases directly on the all architectures. Nevertheless, as Table 2 illustrates, the proposed architectures remains with the lowest signal loads compared to the all architectures.

Table 1: Number of messages in proposed and traditional LTE architectures

Network event	Number of messages		
	LTE architecture	PDCN architecture	FDCN architecture
Initial attachment	10	5	4
A to I & I to A transition	10	2	2
Handover	13	11	6
Tracking area update	3	8	7

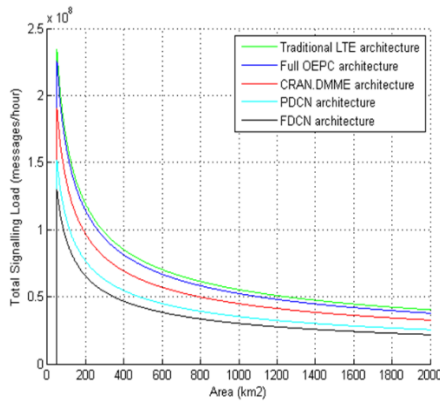

Figure 12: The impact of the area on the architectures

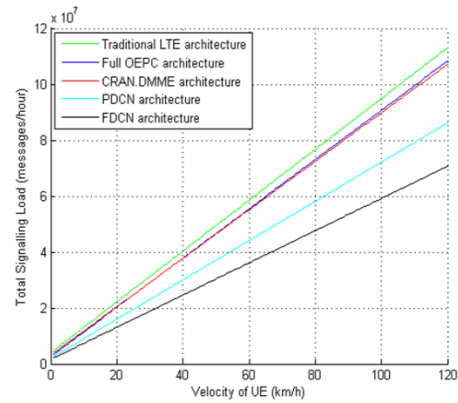

Figure 13: The impact of the UE's velocity on the architectures

Table 2: Average signaling load in each architecture compared with traditional LTE architecture

Architecture	Signaling load (messages/hour)		
	Area	Number of UEs	Velocity
LTE	6.6831×10^7	2.0181×10^4	5.8961×10^7
Full OEPC	6.3485×10^7	1.8921×10^4	5.5862×10^7
CRAN.DMME	5.4252×10^7	1.6345×10^4	5.5506×10^7
PDCN	4.2711×10^7	1.2750×10^4	4.4407×10^7
FDCN	3.6494×10^7	1.0889×10^4	3.6377×10^7

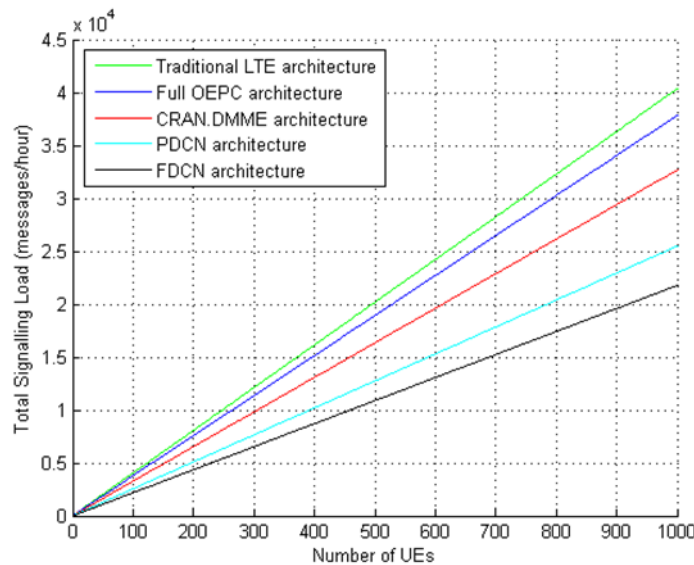

Figure 14: The impact of the number of UEs on the architectures

4. Conclusions

This research indicates, and based on the results obtained when looking at various network parameters, such as area, velocity and user density, it can be argued that the proposed architectures are able to reduce the total signaling load resulting from the signaling messages exchanged between the control entities. When using the proposed PDCN and FDCN architectures, the average signaling load in the LTE architecture was reduced by 36.1 and 45.4 percent, respectively when considering the area size. Moreover, 38.3 and 46.04 percent of the average signaling load have been reduced when analyzing the velocity of the UE and the number of UEs respectively using the FDCN structure. In view of the results obtained, the proposed architectures are effective in terms of reducing the signaling load, but nevertheless, compared to the PDCN architecture, the FDCN architecture is better.

Author contribution

All authors contributed equally to this work.

Funding

This research received no specific grant from any funding agency in the public, commercial, or not-for-profit sectors.

Data availability statement

The data that support the findings of this study are available on request from the corresponding author.

Conflicts of interest

The authors declare that there is no conflict of interest.

References

- [1] D. Wu, H. Shi, H. Wang, R. Wang, and H. Fang, A feature-based learning system for internet of things applications, *IEEE Internet of Things Journal*, 6, (2018), 1928–1937.
- [2] Z. Zhang and L. Wang, Social tie-driven content priority scheme for d2d communications, *Information Sciences*, 480, (2019), 160–173.
- [3] P. Zhang, X. Kang, Y. Liu, and H. Yang, Cooperative willingness aware collaborative caching mechanism towards cellular d2d communication, *IEEE Access*, 6, (2018), 046–67056.
- [4] D. Wu, Q. Liu, H. Wang, Q. Yang, and R. Wang, Cache less for more: Exploiting cooperative video caching and delivery in d2d communications, *IEEE Transactions on Multimedia*, 21, (2018), 1788–1798.
- [5] S. S. Jaffer, A. Hussain, M. A. Qureshi, and W. S. Khawaja, Towards the shifting of 5g front haul traffic on passive optical network, *Wireless Personal Communications*, 112, (2020), 1549–1568.
- [6] A. Viridis, G. Stea, D. Sabella, and M. Caretti, A practical framework for energy-efficient node activation in heterogeneous lte networks, *Mobile Information Systems*, (2017).
- [7] J. Gozalvez, Tentative 3gpp timeline for 5g [mobile radio], *IEEE Vehicular Technology Magazine*, 10, (2015), 12–18.
- [8] S. Sicari, A. Rizzardi, and A. Coen-Porisini, 5g in the internet of things era: An overview on security and privacy challenges, *Computer Networks*, 179, (2020), 107345.
- [9] T.-Y. Wu, Z. Lee, M. S. Obaidat, S. Kumari, S. Kumar, and C.-M. Chen, An authenticated key exchange protocol for multi-server architecture in 5g networks, *IEEE Access*, 8, (2020), 096–28 108.
- [10] J. H. Kim, 6g and internet of things: a survey, *Journal of Management Analytics*, (2021), 1–17.
- [11] P. Varga, J. Peto, A. Franko, D. Balla, D. Haja, F. Janky, G. Soos, D. Ficzer, M. Maliosz, and L. Toka, 5g support for industrial iot applications—challenges, solutions, and research gaps, *Sensors*, 20, (2020), 828.
- [12] D. Chandramouli, R. Liebhart, and J. Pirskanen, *5G for the Connected World*. John Wiley & Sons, (2019).
- [13] J. P. Shim, M. Avital, A. R. Dennis, M. Rossi, C. Sørensen, and A. French, The transformative effect of the internet of things on business and society, *Communications of the Association for Information Systems*, 44, (2019), 5.
- [14] M. Presser, Q. Zhang, A. Bechmann, and M. J. Beliatis, *The internet of things as driver for digital business model innovation*, in *Digital Business Models*. Springer, (2019), 27–55.
- [15] H. E. Yilmaz, A. Sirel, and M. F. Esen, The impact of internet of things self-security on daily business and business continuity, in *Handbook of research on cloud computing and big data applications in IoT*. IGI Global, (2019) 481–498.
- [16] A. Raschendorfer, B. Mörzinger, E. Steinberger, P. Pelzmann, R. Oswald, M. Stadler, and F. Bleicher, On iot as a potential enabler for an m2m economy in manufacturing, *Procedia CIRP*, 79, (2019), 379–384.
- [17] K. David and H. Berndt, 6g vision and requirements: Is there any need for beyond 5g? *IEEE Vehicular Technology Magazine*, 13, (2018), 72–80.
- [18] F. Tariq, M. R. Khandaker, K.-K. Wong, M. A. Imran, M. Bennis, and M. Debbah, A speculative study on 6g, *IEEE Wireless Communications*, 27, (2020), 118–125.
- [19] G. E. Gonçalves, G. L. Santos, L. Ferreira, E. d. S. Rocha, L. M. de Souza, A. L. Moreira, J. Kelner, and D. Sadok, Flying to the clouds: The evolution of the 5g radio access networks, in *The Cloud-to-Thing Continuum*. Palgrave Macmillan, Cham, (2020), 41–60.
- [20] M. Series, Minimum requirements related to technical performance for imt-2020 radio interface (s), Report, (2017), 2410-0.
- [21] A. R. Bahai, B. R. Saltzberg, and M. Ergen, *Multi-carrier digital communications: theory and applications of OFDM*. Springer Science & Business Media, (2004).

- [22] D. Wu, Z. Zhang, S. Wu, J. Yang, and R. Wang, Biologically inspired resource allocation for network slices in 5g-enabled internet of things, *IEEE Internet of Things Journal*, 6, (2018), 9266–9279.
- [23] Y. Cai, F. R. Yu, and S. Bu, Dynamic operations of cloud radio access networks (c-ran) for mobile cloud computing systems, *IEEE Transactions on Vehicular Technology*, 65, (2015), 1536–1548.
- [24] M. Peng, Y. Sun, X. Li, Z. Mao, and C. Wang, Recent advances in cloud radio access networks: System architectures, key techniques, and open issues, *IEEE Communications Surveys & Tutorials*, 18, (2016), 2282–2308.
- [25] N. Gupta, S. Sharma, P. K. Juneja, and U. Garg, Sdnfv 5g-iot: A framework for the next generation 5g enabled iot, in 2020 International Conference on Advances in Computing, Communication & Materials (ICACCM). IEEE, (2020), 289–294.
- [26] R. Shah, V. Kumar, M. Vutukuru, and P. Kulkarni, Turboepc: Leveraging dataplane programmability to accelerate the mobile packet core, in *Proceedings of the Symposium on SDN Research*, (2020), 83–95.
- [27] J. Cho, R. Stutsman, and J. Van der Merwe, Mobilestream: a scalable, programmable and evolvable mobile core control plane platform, in *Proceedings of the 14th International Conference on emerging Networking EXperiments and Technologies*, (2018), 293–306.
- [28] Z. A. Qazi, M. Walls, A. Panda, V. Sekar, S. Ratnasamy, and S. Shenker, A high performance packet core for next generation cellular networks, in *Proceedings of the Conference of the ACM Special Interest Group on Data Communication*, (2017), 348–361.
- [29] T. Sasidhar, V. Havisha, S. Koushik, M. Deep, VK. Reddy, Load Balancing Techniques for Efficient Traffic Management in Cloud Environment, *International Journal of Electrical and Computer Engineering (IJECE)*, 6, (2016), 963-973.
- [30] S. Potluri and K. Subba Rao, Quality of Service based Task Scheduling Algorithms in Cloud Computing, *International Journal of Electrical and Computer Engineering (IJECE)*, 7, (2017), 1088.
- [31] X. An, F. Pianese, I. Widjaja, and U. G. Acer, Dmme: A distributed lte mobility management entity, *Bell Labs Technical Journal*, 17, (2012), 97–120.
- [32] M. Pozza, Solving signaling storms in lte networks: A software-defined cellular architecture, (2016).
- [33] S. B. H. Said, M. R. Sama, K. Guillouard, L. Suci, G. Simon, X. Lagrange, and J.-M. Bonnin, New control plane in 3gpp lte/epc architecture for on-demand connectivity service, in 2013 IEEE 2nd international conference on cloud networking (CloudNet). IEEE, (2013) 205–209.
- [34] M. R. Sama, S. B. H. Said, K. Guillouard, and L. Suci, Enabling network programmability in lte/epc architecture using openflow, in 2014 12th International Symposium on Modeling and Optimization in Mobile, Ad Hoc, and Wireless Networks (WiOpt). IEEE, (2014) 389–396.
- [35] V.-G. Nguyen and Y. Kim, Proposal and evaluation of sdn-based mobile packet core networks, *EURASIP Journal on Wireless Communications and Networking*, (2015), 172.
- [36] I. Al-Samman, A. Doufexi, and M. Beach, A c-ran architecture for lte control signalling, in 2016 IEEE 83rd Vehicular Technology Conference (VTC Spring). IEEE, (2016) 1–5.
- [37] I. Al-Samman, A. Doufexi, and M. Beach, A proposal for hybrid sdn c-ran architectures for enhancing control signaling under mobility, in 2016 IEEE 84th Vehicular Technology Conference (VTC-Fall).IEEE, (2016) 1–6.
- [38] Widjaja, P. Bosch, and H. La Roche, Comparison of mme signaling loads for long-term-evolution architectures, in 2009 IEEE 70th Vehicular Technology Conference Fall. IEEE, (2009).