

Experimental Studies on Shear Connection Between Steel and Steel Fibered Concrete Using Stud

Dr. Khudhayer Najim. Abd-Allah

Building and Construction Engineering Department, University of Technology/ Baghdad

Email:khudhayer67@yahoo.com

Received on: 25/10/2011 & Accepted on:7/6/2012

ABSTRACT

This paper aims mainly to study the effects of using steel fiber in reinforced concrete parts of composite structural elements, which consist of two main parts, the steel and concrete sections. Then to explain the effects of using the hooked ended steel fibers on the load-slip relationship between concrete and steel parts of composite structural elements.

The standard push-out test is a convenient and the only available method to define this load-slip relation. There are five series of tests made on push – out test specimens prepared for this purpose. These tests are containing various percentages of steel fibers (0.0%, 0.5%, 1.0%, 1.5% and 2.0%) by volume of concrete. The hooked ended steel fiber with aspect ratio 100 were used in reinforced concrete parts of composite structural elements, which consist of two main parts (the steel section and the concrete section).

From the obtained results, an empirical non-linear equation was developed, to calculate the shear stiffness for connectors at any amount of slip. This will give information on the ultimate shear capacity of the shear connector, which were used in the composite structures and the corresponding load-slip relationship.

دراسة عملية عن الربط القصي بين المقاطع الفولاذية والخرسانية المعززة بالألياف الحديدية (STUD) باستخدام رباطات القص

الخلاصة

هذا البحث يهدف أساساً الى دراسة استعمال الألياف الحديدية معقوفة النهايات ذات نسبة نحافة (100) في الخرسانية من المقاطع الإنشائية المركبة, ومن ثم توضيح تأثير استخدام مثل هذه الألياف على علاقة (الحمل-الانزلاق) بين المقاطع الخرسانية والمقاطع الفولاذية المكونة للعنصر الإنشائي المركب.

أن الطريقة المتوفرة والشائعة الاستخدام لمثل هذه الفحوصات هي فحص (Standard Push-out Test). في هذا البحث تم أعداد وفحص خمسة مجاميع من النماذج في كل منها نموذجين , وتحتوي هذه المجاميع على نسب حجمية مختلفة من الألياف الحديدية (0,0% , 0,5% , 1,0% , 1,5% , 2,0%) كنسبة حجمية من الخرسانة. من خلال نتائج هذه الفحوصات تم استخلاص معادلة نظرية غير خطية للعلاقة بين الحمل – الانزلاق تأخذ بالحسبان النسبة الحجمية للألياف المستخدمة . باستخدام هذه

المعادلة المستقاة يمكن حساب معامل القص Shear Stiffness لرباطات القص Shear Connectors (Studs) المستعملة عند أي مقدار من الأنزلاق. وأن هذه الفحوصات سوف تعطي معلومات عن سعة القص النهائية Ultimate Shear Capacity لرباطة القص المستعملة وكذلك تعطي تصور عن أشكال الفشل المحتملة.

INTRODUCTION

It is recalled that the main objective is to examine or assess the effects of adding different contents of hooked ended steel fibers to the concrete parts of pushout specimens and show the changes on load-slip relationships of push-out tests (POT).

A standard push-out test is convenient and the only available method to define the connectors properties, where the connectors exposed to a shear forces in the applications of composite constructions in composite elements (beams, floor slabs, columns,.....and etc.). The standard push out test^(1,2) consists of a short steel section connected from two sides with two small reinforced concrete slabs as shown in figure (1).

In 1990, Al-Amery and Roberts⁽³⁾ used the load-slip curve for the connectors in equation (1) which is presented in a modified form to the exponential function suggested by Yam and Chapman.⁽⁴⁾, as follows:

$$Q = Q_u \cdot \{ 1 - \exp(-a \cdot U_{ab}) \} \dots\dots\dots(1)$$

in which, (Q_u) is the ultimate shear strength of a connector and (a) is a constant which can be determined from test results. For example:

$$a = \frac{1}{U_{ab}} \cdot \text{Ln} \left\{ \frac{Q}{Q_u - Q} \right\} \dots\dots(2)$$

in which, (U_{ab}) is the slip corresponding to a load (Q).

EXPERIMENTAL PROGRAM

Specimen Details

The push-out specimens (POT) consist of five groups (in each two specimens), each group is different from the others by its content of the hooked ended steel fiber, which were 0.0%, 0.5%, 1.0%, 1.5% and 2.0% by volume of concrete respectively. These specimens were prepared to examine the behavior (load- slip relationship) when using steel fibers within the concrete provided for casting push-out specimens.

The current specimens of push-out tests were performed on model specimens, having the same basic dimensions as shown Figure (1) . Each specimen consists of 200mm (8 inches) steel section in shape of I-section, and (500mm) long, connected to two fiber reinforced concrete slabs with volume of fractions (0%, 0.5%, 1.0%, 1.5% and 2.0%), and reinforcing steel of f 6mm bars arranged as shown in Figure (2).

The overall dimensions are similar to those used in standard pushout specimens. The connection between the steel section and the two SFRC slabs are represented by two pairs of f 8mm headed studs fixed to both flanges of the steel section.

This investigation comprises casting control specimens for tests of compressive strength and splitting tensile strength from each of five types of mixes. These mixes have different percentages of volume fraction of fibers (0.0%, 0.5%, 1.0%, 1.5% and 2.0%). Two push-out specimens were cast from each type of mixes.

These tests were carried out to provide information on the shear capacity of the shear connectors, which were used in the composite structures and the corresponding load – slip relationship. From this relation the shear stiffness of the connectors can be calculated at any stage of loading. This shear stiffness is used in linear and nonlinear theoretical analysis of composite structures.

Materials Detail

The ordinary Portland cement produced by Al-Kuffa factory and Al-Akaider washed natural sand of 4.75mm maximum size were used throughout this work. The washed coarse aggregate used was Al-Nibaey crushed aggregate of 12mm maximum size. The water cement ratio of 0.27 was used, which is low due to using of superplasticizer (melment L10) with ratio of 3% by weight of cement.

Dramix type of hooked ended steel fibers having a mean diameter of 0.5mm and length of 50mm with an aspect ratio of 100 are used, with different volume of fractions of 0.0, 0.5, 1.0, 1.5 and 2.0 percentage, were used in reinforced concrete parts of composite structural elements, which consist of two main parts (the steel section and the concrete section). To achieve adequate compactability of the fresh fiber concrete and uniform distribution of the fibers without balling or curling up of fibers, the maximum limit of 2% fibers, and the melment L10 as a supplasticiser were used.

Batching and mixing

All the materials were batched by weight and hand mixed. The cement and sand were mixed first. The fibers were then slowly sprinkled by hand into this mixture and mixed thoroughly. The dry mix of cement, sand and fibers was then added to the coarse aggregate and mixed again thoroughly.

The superplasticizer was then slowly sprinkled by hand into the water with mixing to produce the solution. The solution of water and superplasticizer was added to the mix in the final stage and a uniformly distributed matrix was achieved.

Preparation of Concrete Mixes

The concrete mix was designed according to the 1986 British Standard Method. The compressive strength was considered to be the principal factor governing the mix design to have at 28 day compressive strength of about (30) MPa. The water cement ratio of 0.27 was found to give adequate workability with 3% superplasticizer by weight of cement. The maximum size of the used coarse aggregate was 12mm. According to the mix design procedure, a concrete mix with proportions of (1 : 1.7 : 2.2) by weight was used in all the specimens.

In order to determine concrete strength, for each batch, three (150mm x 150mm x 150mm) cubes and three (150mm x 300mm) cylinders were prepared in addition to the pushout specimens.

The same basic mix proportion was used for the plain (control) and the steel fiber reinforced mixes . A total of five mixes were used :

Plain control (reference) mix.

Mix with 0.5% steel fiber by volume.

Mix with 1.0% steel fiber by volume.

Mix with 1.5% steel fiber by volume.

Mix with 2.0% steel fiber by volume.

Test Procedure

A total of 30 cubes, 15 cylinders, 15 flexure beams, 10 and push-out specimens were tested in the experimental program . The control specimens which include the cubes, cylinders and prisms were tested to obtain the compressive strength, splitting tensile strength and flexural strength respectively made by the conventionally used procedures.

The push-out specimens were tested to record the load-slip relations. All the pushout specimens were tested in the universal testing hydraulic machine with a maximum capacity of (250) ton., in which load was applied vertically to the upper end of the steel section. In placing the pushout specimens in the testing machine, care was taken to ensure that the compression load is applied concentrically in order to prevent any lateral movement (separation) for the two concrete plates.

Instrumentation for measuring the relative interface movement between the concrete plates and the steel section (interface slip) consisted of (0.02mm division) dial gauges . Mechanical dial gauges were mounted on steel sections for push-out tests and stopped on concrete sections by using small steel angles fixed on concrete sections .

At each test, the load increment and corresponding interface slip was recorded to plot the load-slip relationship for each percentage of volume of fraction of fiber. Figure (3) shows the details of instrumentation.

Loading was applied slowly in small increments of (2kN) , and stopping loading at each (10 kN) step to take the readings of the dial gages which represents the slip.

The Experimental Tests Results and Discussions

Herein, the general behavior and test observations on pushout specimens, in addition to control specimens are reported and discussed.

As the slip is the function of the concrete strength surrounding the shear strength and the magnitude of fiber included in this concrete, as well as the shear strength of the connector itself. The experimental observations indicate that the shear connectors will not fail if the average load per connector is kept below a certain load which was the critical load of the studs (32 kN). The value of the constant (a) was 1.22 as calculated from the test results of the push-out specimens, which have no fiber and equation.

Pushout Tests Results

A series of ten specimens which represent five groups were tested, in order to provide information on the ultimate shear capacity of the shear connectors, and to show the effects of adding steel fiber to the concrete matrix used in preparing of these pushout specimens. The recorded results will show the probable reflections on produced load-slip relationship, for the used studs, and then to develop a general relationship for load-slip included effects of addition of steel fiber in any volume of fractions up to 2.0% by volume of concrete.

Load –Slip Relationship

Figure (4) shows the typical experimental load – slip curves at interface between steel section and attached reinforced concrete (concrete wings), for a single shear connector in test specimens of POT. The slip values are the average recorded slips from one pair of specimens. From these curves, shear stiffness of a connector at different fiber contents are obtained. Figure (4) shows a large increase in ductility with increasing fiber volumes. It should be noted that no noticeable increase in the peak loads was observed indicating that actually a decrease in slip stiffness has occurred. The large slips indicate that the inclusion of fibers results in general improvement in slip toughness (area under the curve of load-slip curve).

Proposed formula on pushout

Depending on the tests results and curves after using curve fitting and building on form which used by [Al-Amery and Roberts]⁽³⁾, and to include the effects of addition of steel fiber to the concrete, on the load-slip relationship, proposed (suggested) the following form:

$$Q = Q_u \cdot \{ 1 - \exp(-a (1-0.46\sqrt{V_f})U_{cs}) \} \dots\dots\dots(1)$$

Where:

- Q = shear strength (kN),
- Q_u = The ultimate shear strength of a connector (32 kN in our case),
- a = constant (1.22 in our case determined using equation 2),
- V_f = percentage of volume fraction of fiber and
- U_{cs} = interface slip between concrete wings and steel section in pushout Specimens.

The curves plotted from the above suggested equations (equation (3)) for different percentages of fiber contents are plotted in Figure (5). The comparisons between these curves and that from experimental test are shown in Figures (6), (7), (8), (9) and (10) to see the suitability and validity of this proposed form. It can be seen that the predicted equation agree well with the experimental results.

The proposed form of load-slip relationship for fiber reinforced concrete POT could be used.

Elastic Shear Stiffness

The shear stiffness ' K_s ' can be defined as the load required per connector to produce unit slip. The load - slip curves were nonlinear, and to determine the elastic stiffness for each curve (for each V_i), choose the line extended between the origin point (point of zero load and zero slip) and point of half ultimate load ($\frac{1}{2} Q_u$) for this curve see Figure (11), Table (4) and Figure (12).

The slopes of these curves represent the shear stiffness required for linear numerical analysis and as initial stiffness for nonlinear analysis..

From Table (4) and Figure (12) which present the initial shear stiffness , it can be seen that the elastic stiffness decreased with increasing the fiber content.

Ultimate Shear Capacity and Maximum Recorded Slip

The maximum experimental shear stress resisted by one connector for each specimen was 32 kN (This load represents the ultimate carrying capacity of studs), at which , if no one of the two reinforced concrete plates or both failed (cracked), at this instant the failure occurs by cutting of the studs in one of the two attached concrete slabs depend on balancing of load concentration on specimen into account (this case of failure occurred specially in specimens having fiber content of 1% and 1.5% by volume of concrete).

The maximum slip recorded for the POT specimens varies with the percentages of volume fraction of fiber. The magnitude of maximum slip was 3mm, 5mm, 8mm, 9.5mm and 10mm for specimens containing 0.0%, 0.5%, 1.0%, 1.5% and 2.0% hooked ended steel fiber by volume of concrete respectively.

Failure Modes

The type of failure of tested specimens was either horizontal cracks in inner faces of reinforced concrete plates or cutting the shear connectors (studs). There was no appearance of cracks on the outer sides of concrete plates for all tested specimens and no sign of deformations appeared on the steel sections for all specimens. When the failure occurred by shearing off the bolts at the interface between the reinforced concrete plates and steel section, there was a little concrete crushing that occurred prior to failure of the connector at the direction of loading. Figure (13) shows one of the failed specimens.

Finite Element Applications

To illustrate the applications of the predicted load slip relationship on the composite beam shown in Figure (14) was used ANSYS finite elements program. To model this composite beam, the Solid-65 Element is used for the 3-D solids without reinforcing bars (rebar). Link-8 Element Description (3-D Spar or Truss Element Bar) is used as reinforcing bars and as shear connectors to resist the uplift forces of the shear connectors in the composite beam. Combin-39 element is a unidirectional element with nonlinear generalized force-deflection capacity that can be used in any analysis, the shear forces of the shear connectors are simulated by this element so the results of the load-slip curve for push-out test achieved in this research are used in the

analysis of this element. The results of the analyzed beam were plotted in Figure (15). The Figures (16) to (18) show the model and stresses distribution along the beam.

REFERENCES

- [1]. Adekola, A. O., “ Partial Interaction Between Elastically Connected Elements of A Composite Beam,” Journal of Solids and Structures, Vol. 4, 1968, pp. 1125 – 1135.
- [2]. Coplin Davies, “ Steel-Concrete Composite Beams for Building,” Eyre and Spottiswoode Ltd., London, U.K.,1975.
- [3]. Al-Amery, R. I. M. and Roberts, T.M.,” Nonlinear Finite Difference Analysis of Composite Beams with Partial Interaction”, Journal of Computers and Structures, Vol. 35, No. 1, 1990, pp. 81 – 87.
- [4]. Yam, L. C.P. and Chapman, J. C.,” The Inelastic Behavior of Simply Supported Composite Beams of Steel and Concrete”, Proc. Instn. Civ. Engrs.,Vol. 41, 1968,pp. 651 - 683.

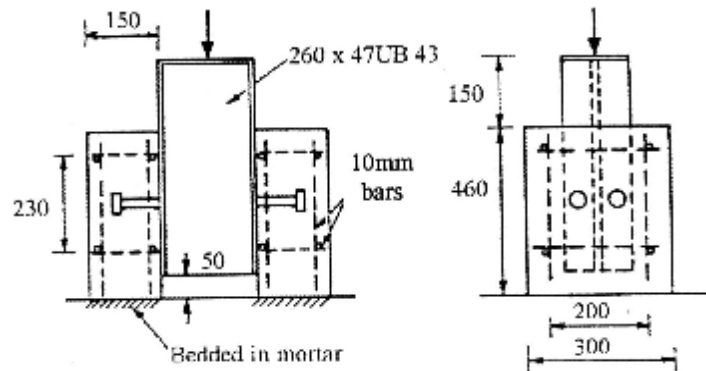

Figure (1): Details of standard push-out test specimens (All dimensions in mm).

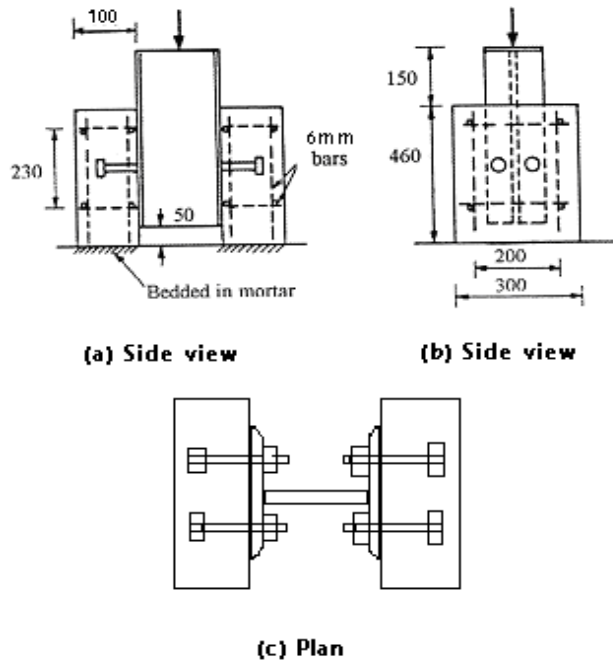
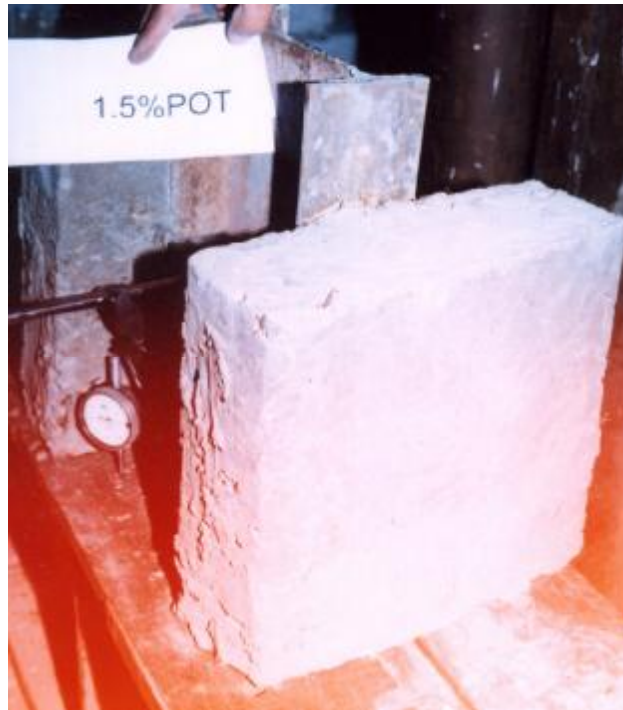

Figure (2): Details of used push-out test specimens (All dimensions in mm).

Table (1): List of Test Specimens and these Properties.

| Series No. | Group name(fiber % V_f) | Specimens Type | Type of Test |
|--------------------|-----------------------------|---------------------------|---------------------------------|
| Control Specimens. | 0.0% | Cubes (150mm x 150mm) | Compressive Strength Test |
| | 0.5% | | |
| | 1.0% | | |
| | 1.5% | | |
| | 2.0% | | |
| Control Specimens | 0.0% | Cylinders (150mm x 300mm) | Splitting Tensile Strength Test |
| | 0.5% | | |
| | 1.0% | | |
| | 1.5% | | |
| | 2.0% | | |
| POT | 0.0%POT | Push-out Specimens | Push-Out Test |
| | 0.5%POT | | |
| | 1.0%POT | | |
| | 1.5%POT | | |
| | 2.0%POT | | |



Figure(3) : Photograph of Measurements of interface slip instrumentation.

Table (2): Compressive Strength Test Results.

| Specimens Type | Specimens Designation | V _f % | Compressive Strength, (MPa) |
|------------------------|-----------------------|------------------|-----------------------------|
| Cube Control Specimens | 0.0% | 0.0 | 24.85 |
| | 0.5% | 0.5 | 27.20 |
| | 1.0% | 1.0 | 36.00 |
| | 1.5% | 1.5 | 33.82 |
| | 2.0% | 2.0 | 30.67 |

Table (3): Splitting Tensile Strength Test Results.

| Specimens Type | Specimens Designation | V _f % | Splitting Tensile Strength, (MPa) | Percentage of increasing |
|----------------------------|-----------------------|------------------|-----------------------------------|--------------------------|
| Cylinder Control Specimens | 0.0% | 0.0 | 3.10 | ----- |
| | 0.5% | 0.5 | 3.76 | 21.3% |
| | 1.0% | 1.0 | 5.40 | 74.2% |
| | 1.5% | 1.5 | 5.404 | 74.4% |
| | 2.0% | 2.0 | 5.45 | 75.8% |

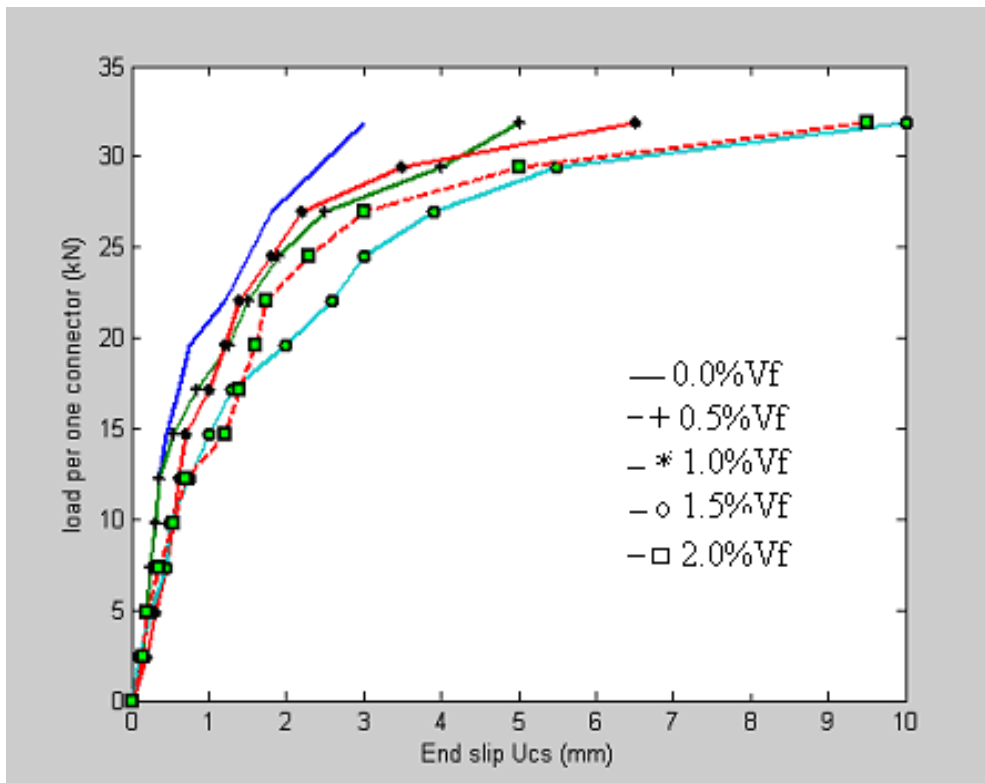

Figure (4): Experimental load – slip relationship for pushout Tests (POT).

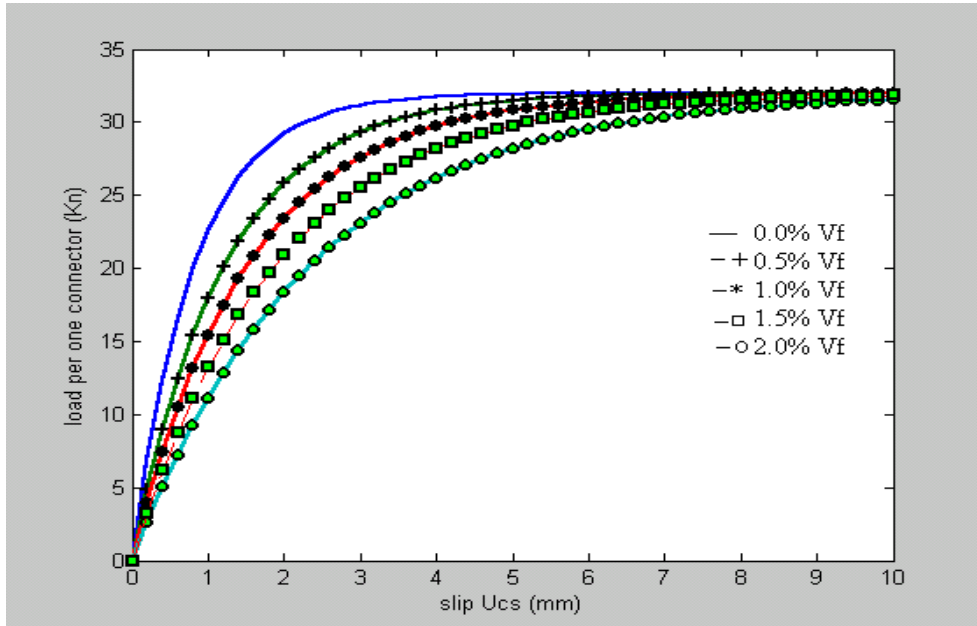

Figure (5): The Suggested Load-Slip relationships for different Vf Eq.(3).

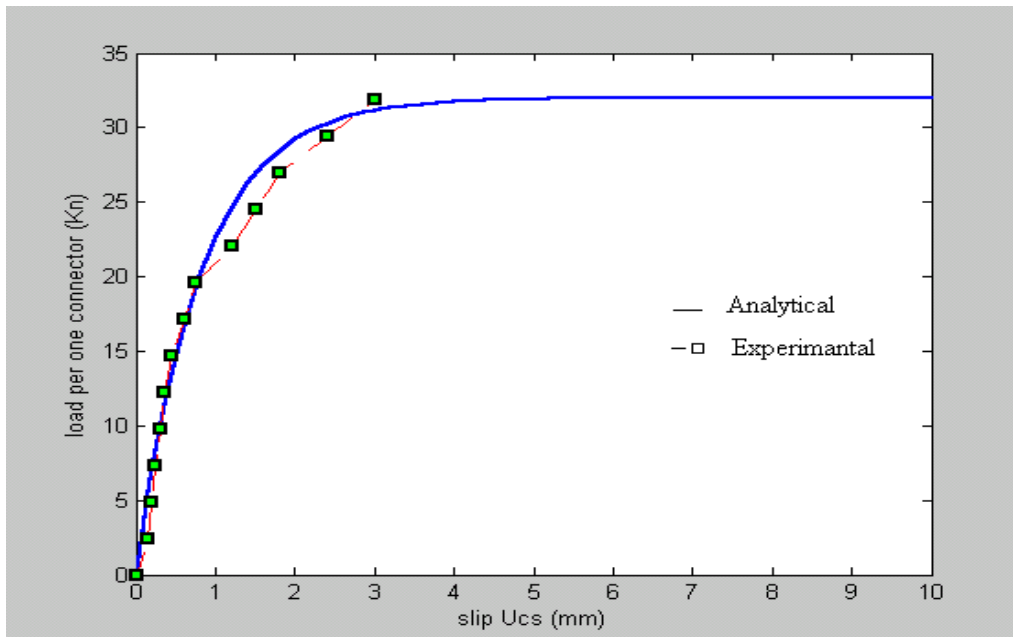

Figure (6): The Experimental and Suggested Theoretical Load-Slip relationships for 0.0% Vf .

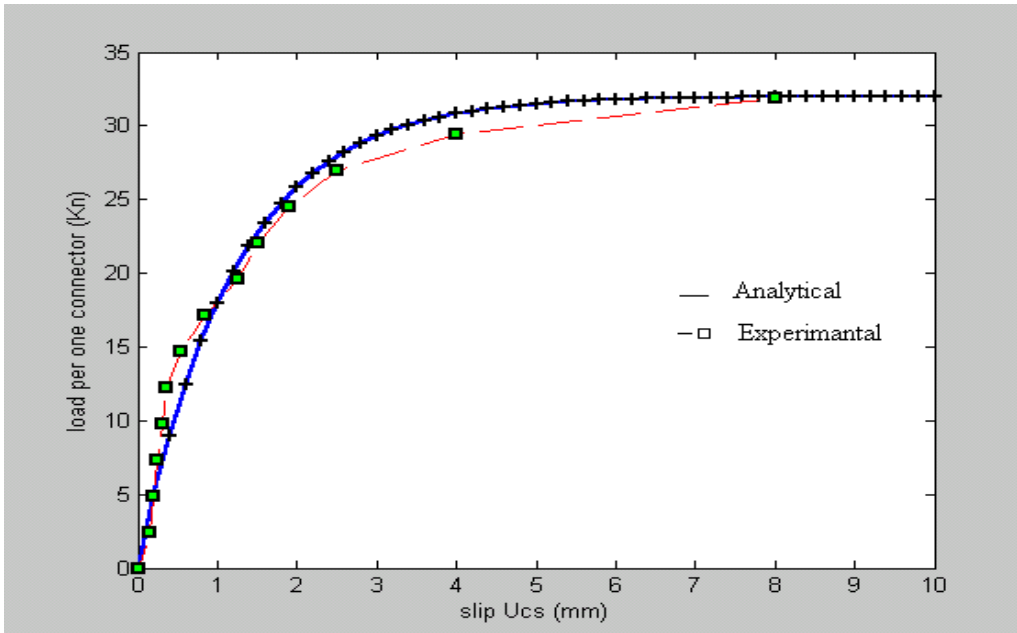

Figure (7): The Experimental and Suggested Theoretical Load-Slip relationships for 0.5% Vf .

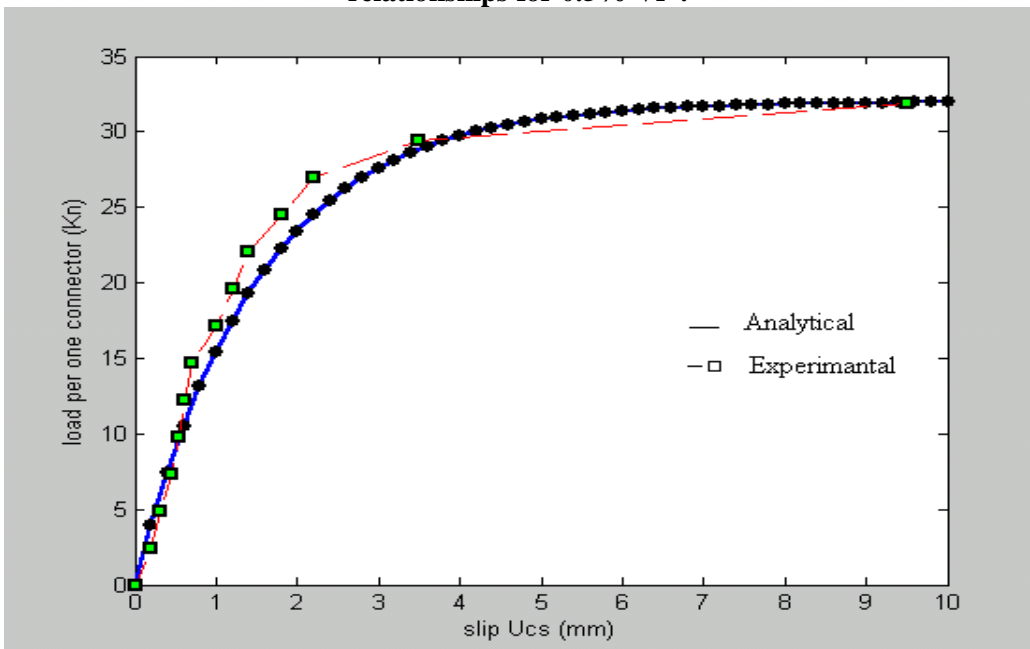

Figure (8): The Experimental and Suggested Theoretical Load-Slip relationships for 1.0% Vf

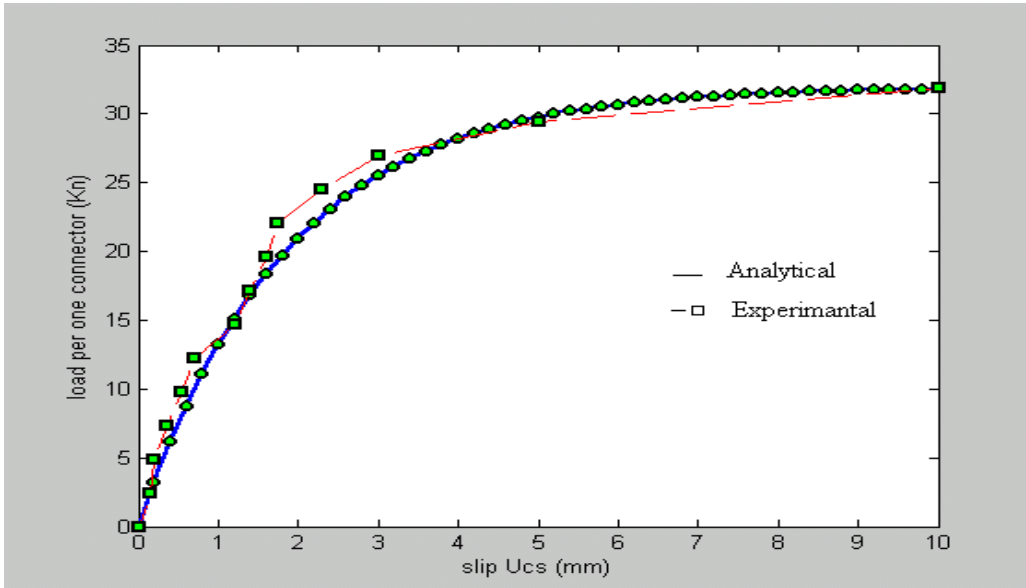

Figure (9): The Experimental and Suggested Theoretical Load-Slip relationships for 1.5% Vf .

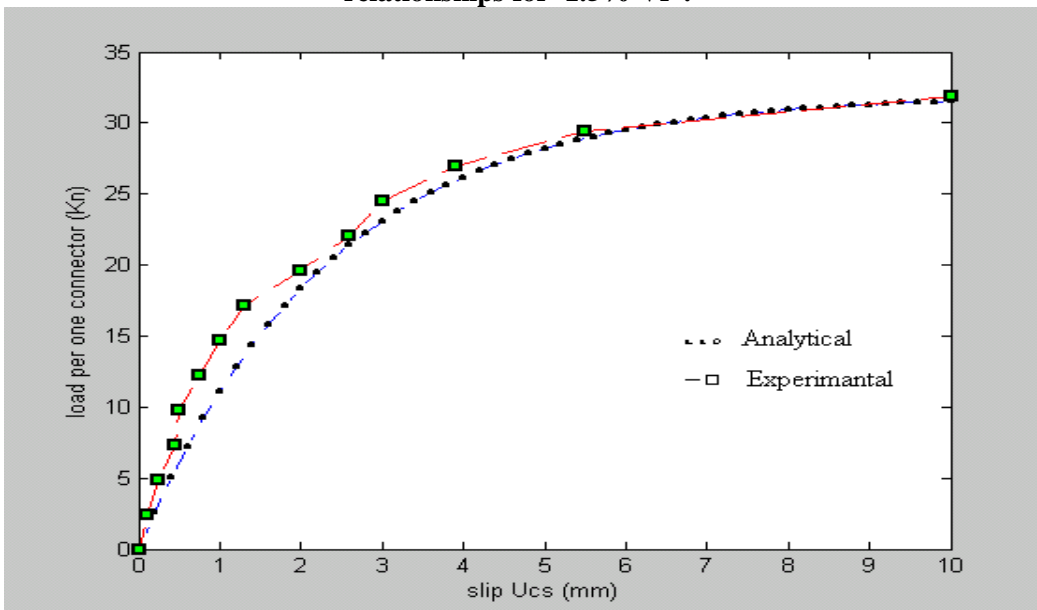

Figure (10): The Experimental and Suggested Theoretical Load-Slip relationships for 2.0% Vf .

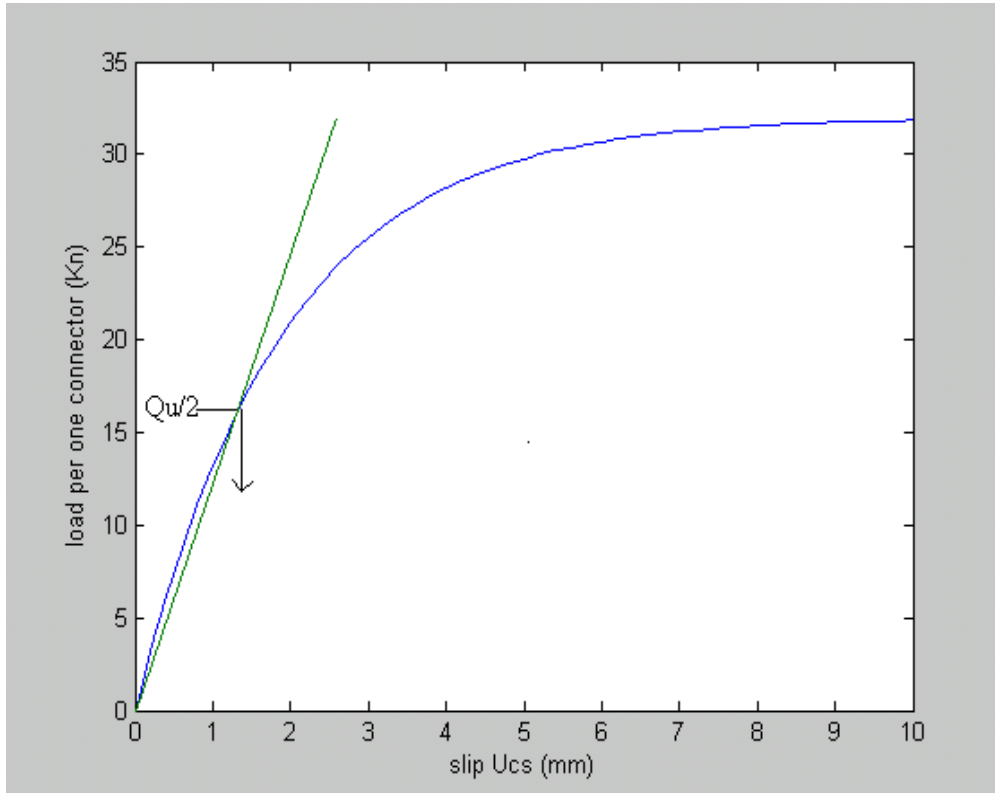

Figure (11): Elastic Modulus of Elasticity.

Table (4): Experimental and Theoretical Elastic Shear stiffness for Push – Out Test Results.

| Specimen type | %Vf | Half Qu (k) | Ucs at Qu/2(mm) Theoretical EQ.(3) | Ucs at Qu/2 (mm) Experiment | Elastic Ks (kN/mm) Theoretic. Eq.(3) | Elastic Ks (kN/mm) Experimental | Ks Theo./ Ks exp. |
|---------------|------|-------------|------------------------------------|-----------------------------|--------------------------------------|----------------------------------|-------------------|
| POT | 0% | 16 | 0.56825 | 0.530 | 28.16 | 30.19 | 0.933 |
| | 0.5% | | 0.842 | 0.71 | 19.0 | 22.5 | 0.845 |
| | 1% | | 1.052 | 0.857 | 15.21 | 18.67 | 0.815 |
| | 1.55 | | 1.301 | 1.305 | 12.3 | 12.26 | 1.00 |
| | 2% | | 1.626 | 1.157 | 9.84 | 13.83 | 0.711 |

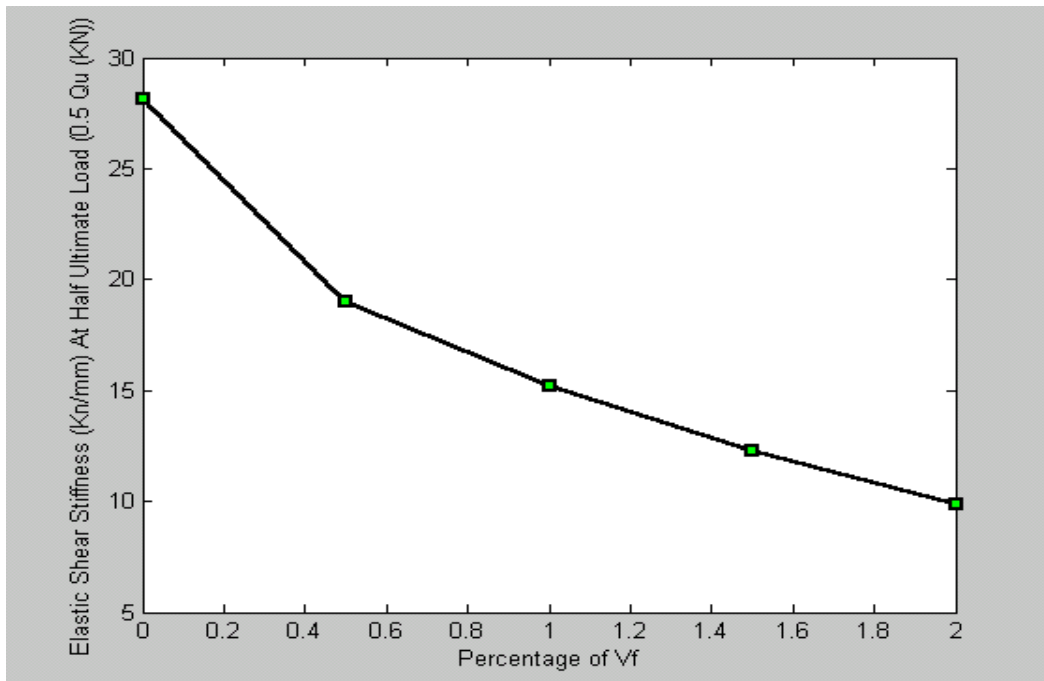

Figure (12): Elastic Shear Stiffness Versus Percentages of fiber.



Figure (13): Photograph of Tested POT Specimen Showing the Failure mode.

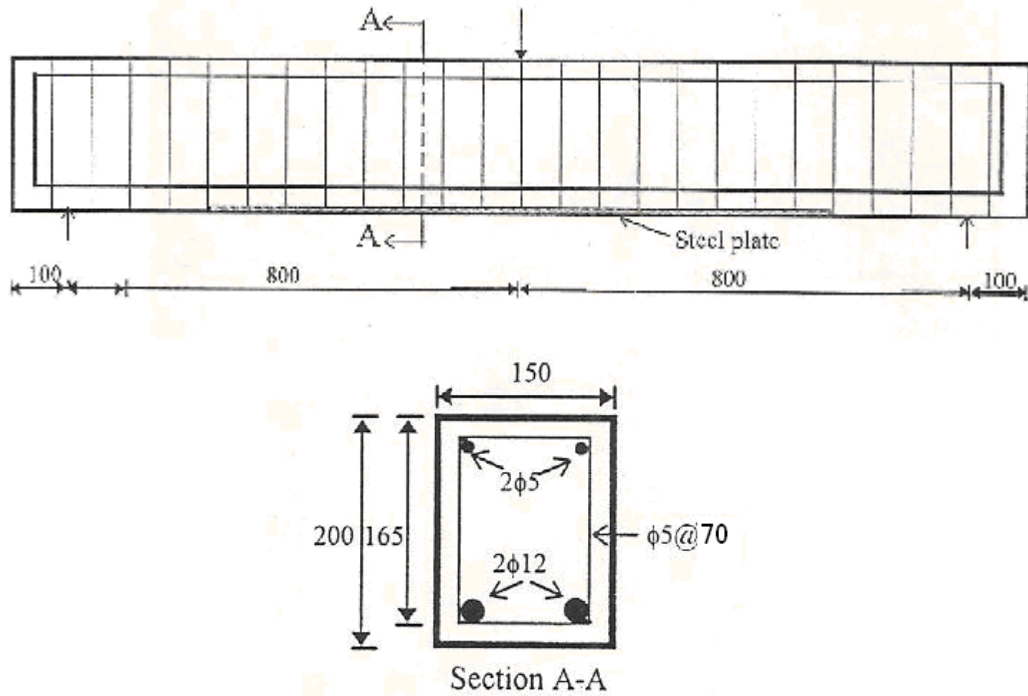
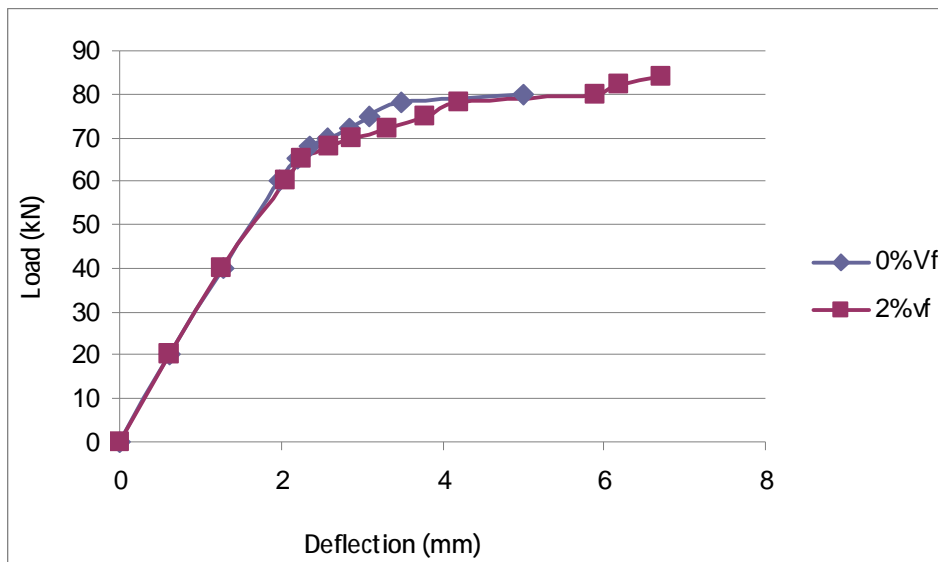

Figure (14): Analyzed Beam.



Figure(15) Load Deflection for 0% and 2% Vf.

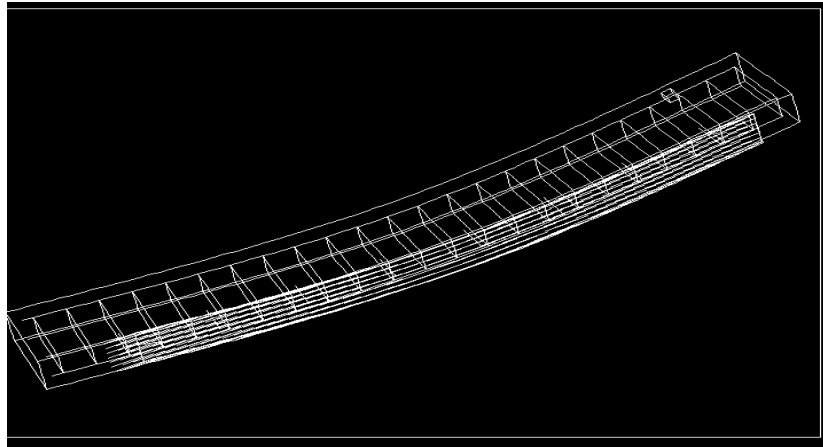

Figure (16) : The beam model.

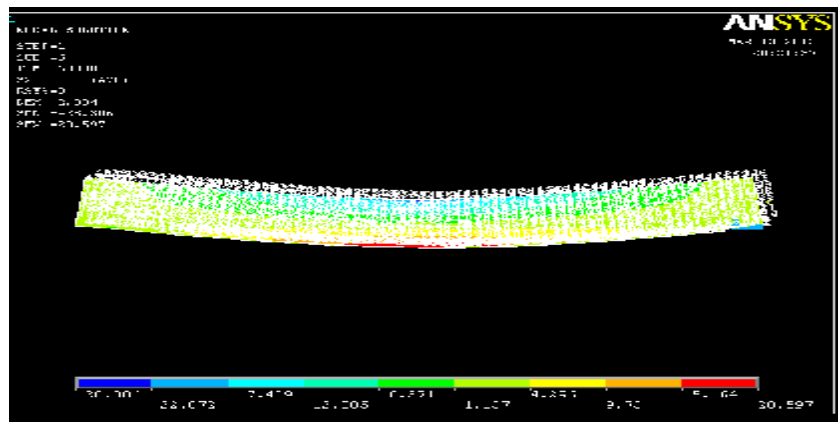

Figure (17): Stress Distribution Along the Beam.

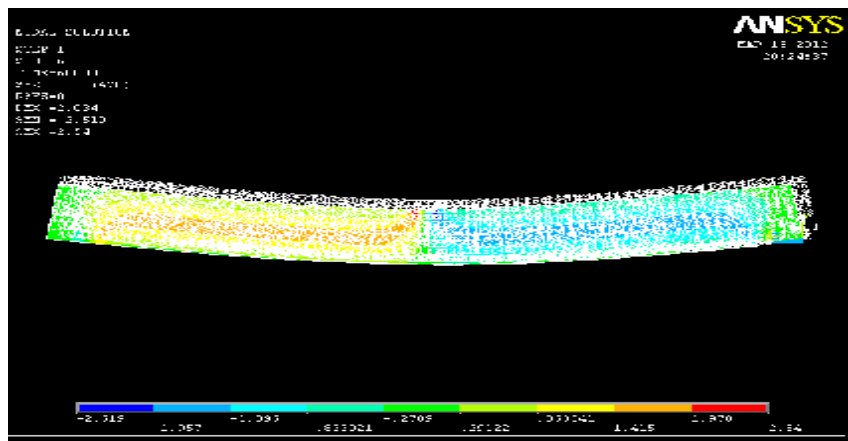

Figure (18): Shear Stresses Along the Beam.