



## Numerical and Experimental Explorations for the Formability of Drawing Square Cups Through Deep Drawing Operation (January 2020)

Nareen H. Obaeed <sup>a\*</sup>

<sup>a</sup> Dept. of Production Engineering and Metallurgy, University of Technology, Baghdad, Iraq, 70219@uotechnology.edu.iq

\*Corresponding author.

Submitted: 23/11/2019

Accepted: 23/12/2019

Published: 25/09/2020

### KEY WORDS

Formability, square cup, deep drawing, FE simulation, thickness strain.

### ABSTRACT

*This study aims to examine the formability of drawing cups having square shapes through direct deep drawing process on a single action press through one pass. This can be accomplished by conducting an FE simulation and performing an experimental investigation on steel substrate type AISI 1008 blank with diameter and thickness dimensions 80, 0.5 mm respectively. To explore and analyze the formability of such a drawing process, two process parameters have been included in this work which is the speed of punch (30 and 300 mm/min) and the lubrication state (with machine oil and dry drawing). Both direct and indirect measurements of thickness strain have been adopted as an indicator of the sheet formability. The results of both FE simulation and experimental work demonstrate that the square drawing of the AISI sheet has been accomplished for all the four cups produced since the highest thinning over the cup wall does not exceed 25% of the original thickness. Generally, there is a good match between the experimental values of the indirect method and the FEM results for all models such that the largest deviation is about 25%. The direct method of thickness measurement is determined to be non-confident as strain values are practically unacceptable. Additionally, higher formability of the sheet has been realized at lower punch speeds. Furthermore, no significant difference has been observed in the formability at both speeds of punch when using a lubricant compared to the dry drawing operation.*

**How to cite this article:** N. H. Obaeed "Numerical and experimental explorations for the formability of drawing square cups through deep drawing operation," Engineering and Technology Journal, Vol. 38, Part A, No. 09, pp. 1316-1326, 2020.

DOI: <https://doi.org/10.30684/etj.v38i9A.1340>

This is an open access article under the CC BY 4.0 license (<http://creativecommons.org/licenses/by/4.0>).

### 1. Introduction

Sheet forming is one of the most commonly utilized manufacturing operations for the production of a

wide collection of parts in numerous industries. Cylindrical, rectangular, and some complex-shaped parts can be produced with the help of this process [1]. Deep drawing is considered as the most effective technique in sheet metal forming technology applied in the industry for a wide range of applications. The automotive industry represents a remarkable market in this field [2]. Deep drawing is a process for the formation of sheet metals, in which, a blank is drawn radially using the mechanical action of a punch into the forming cavity. This process involves several input parameters, including the die shoulder radius, punch nose radius, blank holder force, and the clearance between a punch and die. A schematic of the square deep drawing operation is shown in Figure 1 [3].

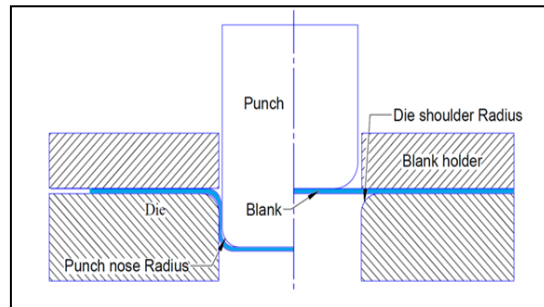

**Figure 1: Schematic of the square-section deep-drawing process [3].**

Suggested solutions for enhancing the formability of square cups can be categorized into three strategies: (1) change the instability condition and the stress state in the deformation region. (2) enhancement of process parameters such as tool geometries, friction, and lubrication conditions, material properties, forming temperature, optimum blank shape, etc. and (3) material properties belong to formed sheet metal had been an improvement. Based on the second strategy which concentrates on the selection of many process variables, many attempts by the researchers have been conducted to improve the formability of square cups produced. Hassan et al. (2014) [4] have found that square cups drawability increasing with the deformation characteristics via deep-drawing operation through conical dies. The analysis disclosed that assigning proportional increment in drawing ratio. It was founded that drawing ratios up to 3.15, 3.1 for aluminum type (Al99.5w), brass alloy type (67/33 Cu-Zn) respectively, in one-pass drawing with the optimum setup dimensions of the constructed operation. Harada and Ueyama [5] have investigated the formability of pure titanium sheet by square cup deep drawing. It was stated that the square cups of pure titanium were successfully drawn through using treatment with a heat oxide coating. Shewakh et al. [6] have introduced the analysis of FEM and the empirical verification referred to the drawing of a square cup of the brass alloy (CuZn37) and an annealed aluminum (AL99.5w) having an initial thickness of 3, 2.5 and 2 mm. The finite element and experimental results presented a very good match between results of failure modes, deep drawing loads, and limiting drawing ratios. Tenner et al. [7] have analyzed both numerical, experimental investigations on deep drawing operation type dry of Al alloys in comparison to lubricated processes. The results revealed that with traditional equipment direct contact has produced adherent wear and thus the rectangular cup had been failed. Therefore, the deep drawing of aluminum was impossible in the absence of lubrication. Younis et al. [8] have performed numerical analysis and experimental work to explore the influence of some parameters such as radial clearance between punch and die, blank diameter and die profile radius respecting to thickness distributions and length of a square cup. It is determined that the greatest thinning appears in the cup corner owing to the extreme stretching that occurs in this zone beside it is demonstrated that the height and cup thickness prediction by numerical investigation matches generally with the experimental analysis. Reichardt and Liewald [9] have dealt with experimental explorations on the tribological conditions of friction at tool radii with the presence of volatile lubricants, such as  $N_2$  and  $CO_2$  through the deep drawing process. The introduced investigations demonstrate the feasibility of such a tribological system with lubricant substitute as volatile media. Even with rather large retention forces, an arrangement of simple microhole can preclude wear owing to cohesion or adhesion. Suttner et al. [10] have realized a cross-profile of the deep drawing operation in order to study the spring back attitude for a magnesium alloy AZ31 by different forming temperatures. The results disclosed that no considerable influence of anisotropy on the angle spring back can be noticed for AZ31B with raising the forming temperature. Besides, a reduction of forming temperature

causes an increase of the spring-back angle, also noticed at lower temperatures losing size accuracy taken place.

As a result of the previous findings reached by many researchers, this work aims to investigate the effects of some relevant parameters on the sheet formability through a deep drawing process for producing square-shaped cups during one pass. This can be accomplished by carrying out a numerical simulation and performing an experimental verification on a mild carbon steel sheet blank. Consequently, thickness strain has been adopted as an indicator of formability by considering two process parameters which are the drawing speed and the lubrication state.

## 2. Methodology

The main steps utilized for accomplishing the current study can be summarized as follows:

1. Selecting the parameters of the drawing process to be included.
2. Conducting the FEM models of the drawing operation by utilizing the parameters specified.
3. Performing the experimental work by drawing the square cups.
4. Measuring strain values of the produced cups.
5. Analysis of both FEM and experimental results.

## 3. Drawing Parameters

In this work, the parameters that have been adopted are the drawing speed and the lubrication status for both FE simulation and experimental validation. The following sections will illustrate each parameter.

### I. Drawing Speed

The speed of drawing corresponds to the velocity that the punch travels during the drawing operation. Two values have been utilized: 30 and 300 mm/min for both FE simulation and experimental tests such that the second level of speed has been increased ten times so that investigate the impact of this parameter on the drawing process.

### II. Lubrication State

In addition to dry drawing, machine oil is also used between the blank and the die to, explore the impact of the presence of lubricant on the drawing process.

The FE models and the experimental runs that can be accomplished are listed in Table 1 by using the possible interactions of the parameters included in this work.

**Table 1: Conditions of FE models and experimental runs adopted in this study**

| Sample/Mode<br>l No. | Drawing Speed<br>(mm/min) | Lubrication State |
|----------------------|---------------------------|-------------------|
| 1                    | 30                        | Machine Oil       |
| 2                    | 300                       | Machine Oil       |
| 3                    | 30                        | Dry               |
| 4                    | 300                       | Dry               |

## 4. Finite Element Simulation

"Finite element analysis" (FEA) is the technique of simulation, which estimates the attitude of structures, products, and equipment for various conditions of loading. "DFORM" program version 10.2 software package has been used for simulating the deep drawing process. 3D finite element (FE) models were imported and appropriate material has been assigned to the models. The different stages of the emulation work are summed up successively at the subsequent steps:

**(a) Preprocessing:** commences with problem definition which involves importing the geometry of top and bottom dies as well as blank as solid models, meshing the blank volumes as needed, and specifying material together with geometric properties.

(b) **Solution:** includes applying loads/speed, positioning objects (rotational and translational), simulation control, setting primary die stroke, generating a database, switching to simulate, and eventually solving the problem.

(c) **Post-processing:** comprises of extra processing as well as viewing of the results with tools and stating variables.

*I. Parts Modeling*

Commonalty parts involving dies, punches, and blank were modeled as solid geometries utilizing AutoCAD 2016 software and then exported to DEFORM as STL files. Figure 2 shows the assembly of the modeled parts. It is necessary to point that the dimensions of the blank are 80 mm in diameter and 0.5 mm in thickness. The whole, details of dimensions for the drawing components adopted in this study can be seen in Figure 3.

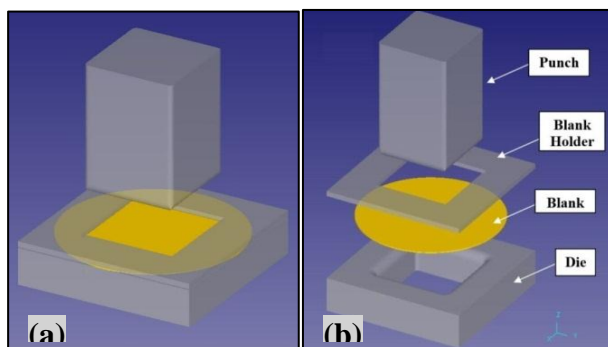
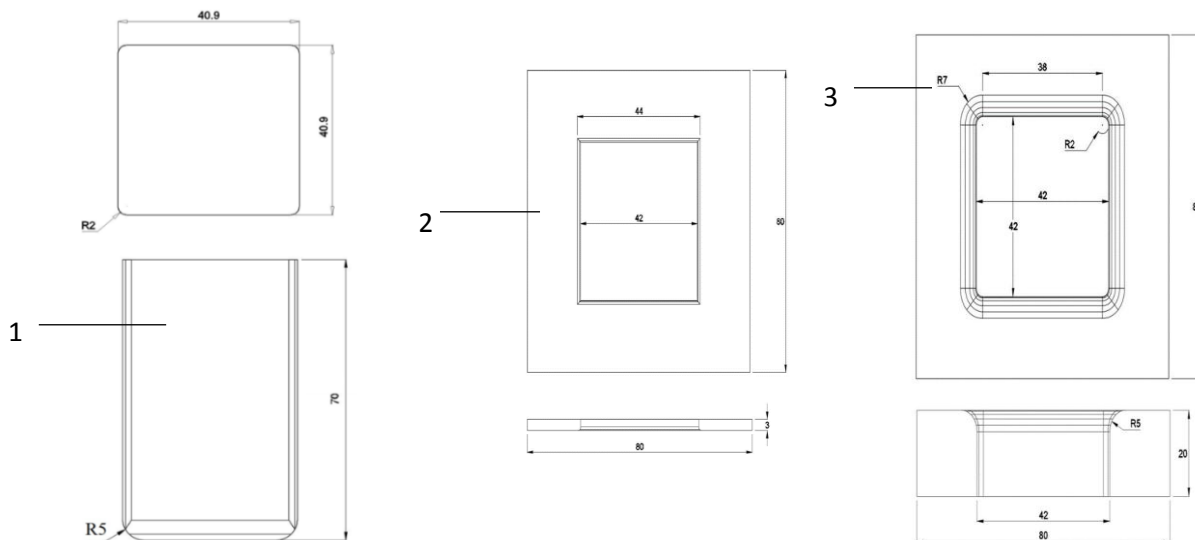

Figure 2: Parts assembly for FE simulation; (a) primary setup and (b) exploded view



| Part No.                | ITEM         | No |
|-------------------------|--------------|----|
| 1                       | punch        | 1  |
| 2                       | Blank Holder | 1  |
| 3                       | Die          | 1  |
| Deep Drawing components |              |    |

Figure 3: Schematic representation of the top and cross-view of various components of deep drawing adopted in this work

*II. Elements and Meshing*

The element geometry that is utilized in the FE analysis affects the precision of the conclusion to a large range. Investigations of peer researchers' works and literature review demonstrate that 3D elements with tetrahedron shape have been appropriately adopted in the numeral analyses of anisotropic forming

operations. This element can represent the effect of large deflection with plastic capabilities. The foremost reason to adopt such element shape is the automatic re-meshing that is accompanied by DFORM 3D for the extremely damaged element shape once emulation is Size of element functions a significant role during the simulation. A dimension of an element affects both the computation time and the accuracy of the results. The blank ought to have meshed finer enough to obtain a satisfactory outcome. Although, element number increment leads to an extreme prolonging in computation time. In the introduced work, in order to realize accurate results, the number of elements and nodes for the model of the blank is set to be 69812 elements and 22860 nodes respectively. The meshing process of the sheet can be seen in Figure 4.

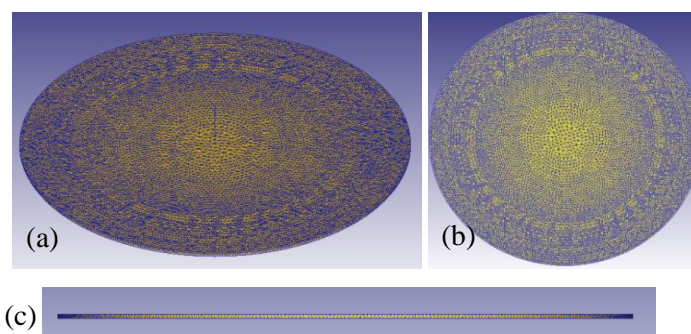

**Figure 4: Meshing of the blank; (a) 3D scene, (b) Top view and (c) Sectional view**

### III. Material of Blank

Low carbon steel type AISI 1008 grade is the blank material. It was specified as a plastic material model in the introduced DFORM-3D simulation. The rigid die and punch are presumed, thus there is no necessity to define a material. The chemical composition of AISI 1008 material is depicted in Table 2 while, its mechanical properties can be shown in Table 3 [11].

**Table 2: Chemical composition of AISI 1008 [11]**

| Material    | C%   | Mn%  | Si%   | S%    | Ni%   | Cr%  | Mo%   | Ti%   | Cu%  |
|-------------|------|------|-------|-------|-------|------|-------|-------|------|
| Used SS 304 | 0.06 | 0.36 | 0.015 | 0.033 | 0.059 | 0.03 | 0.029 | 0.008 | 0.05 |

**Table 3: Mechanical properties of AISI1008 [11]**

| Item No. | Mechanical Property       | Value   |
|----------|---------------------------|---------|
| 1        | Young's Modulus           | 200 GPa |
| 2        | Ultimate Tensile Strength | 380 MPa |
| 3        | Yield Stress              | 234 MPa |
| 4        | Strain Hardening Exponent | 0.214   |
| 5        | Poisson's Ratio           | 0.3     |
| 6        | Coefficient of Friction   | 0.1     |

It is extremely important to mention that the friction coefficient for FE simulation with machine oil has been set to be 0.05 which is the half value of that for the dry friction to take the tribological conditions of lubricant into account.

### IV. Boundary Conditions and Loading

As an essential aspect of finite element analysis, applying loads/speeds and limit conditions comprises depicting who parts of geometrical models shifts (e.g. specifying the degree of freedom). Pairs of touch surfaces included in the present study are bottom blank - top die, top blank – bottom blank holder, and top blank - bottom punch. In the present work, the punch travel is set toward the downward Z- direction. The motion of the blank which is on the die is unrestrained in both x and y-directions to permit the blank to slide over the die bore. The punch, blank holder, and die are set solid during FE simulation as they are extremely stiff compared to the material of the blank.

### V. Solution Phase and Viewing of Cups

A correct geometric modeling, meshing, and proper applying of loads and boundary conditions have been accomplished. The punch velocity is applied and the problem is executed for the material type AISI 1008. The simulation has been run after settings had been finished. The solution has been performed with displacement increments, for an ultimate number of steps set as 1250 and a minimal as 10 that exemplify the accretion of step corresponding to the constant displacement of punch equivalent to 0.05 mm per step for completing the whole punch stroke which is regulated to be 50 mm to finalize the entire drawing operation as well as to ensure the exit of the drawn cup entirely from the die cavity. The FE simulation of the resulting drawn cups simulated by DEFORM software is shown in Figure 5. Besides, the effective strain distribution on the simulated drawn cups for the four models (listed in Table 1) at various process parameters is shown in Figure 6. It is worth noting that the dimensions of the drawn cup are 41.9×41.9×26 mm.

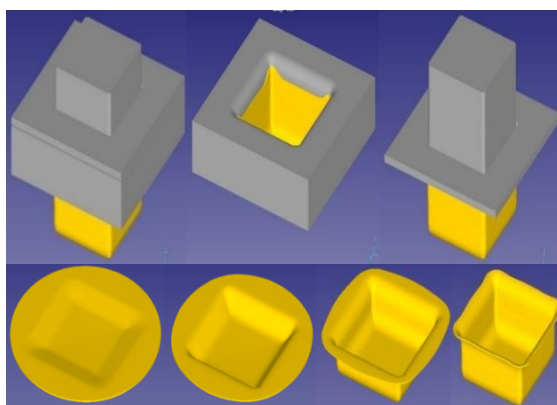

Figure 5: Different views for FE simulation of the drawn-square cup

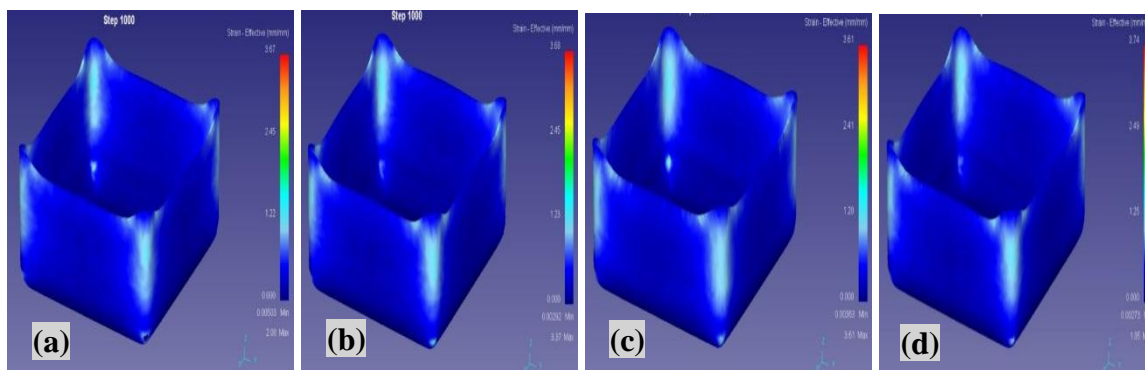

Figure 6: Effective strain distribution on the simulated-square cups for model No.: (a) 1, (b) 2, (c) 3, (d) 4

## 5. Experimental Work

### I. Experimental Setup

The blank preparation starts at cutting the blank with the required dimension. The experiments of deep drawing have been performed in the Strength of Materials Laboratory in the Production Engineering and Metallurgy Department at the University of Technology. The instrument machine model (WDW200E) with 200-ton amplitude has been adopted for this drawing operation. A 3×3 mm mesh grid has been printed on the blank surface by Fiber Laser Machine for strain measurement as shown in Figure 7-a. Figure 7-b represented the mounted die set on a hydraulic press. The aforementioned press was concerted with a PC, which records the punch stroke and loads automatically through a load cell as shown in Figure 7-c. Drawing speeds of 30 and 300 mm/min have been chosen to draw the blank for both dry and lubricated drawing operations.



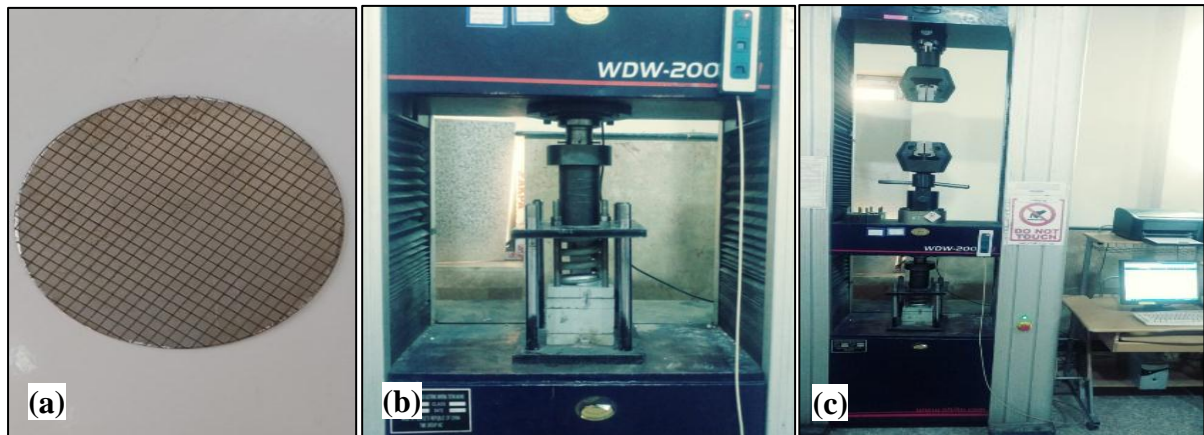

Figure 7: Drawing equipment; (a) blank used, (b) die set with a hydraulic press, and (c) the whole setup

The produced square cups by the deep drawing operation can be seen in Figure 8.

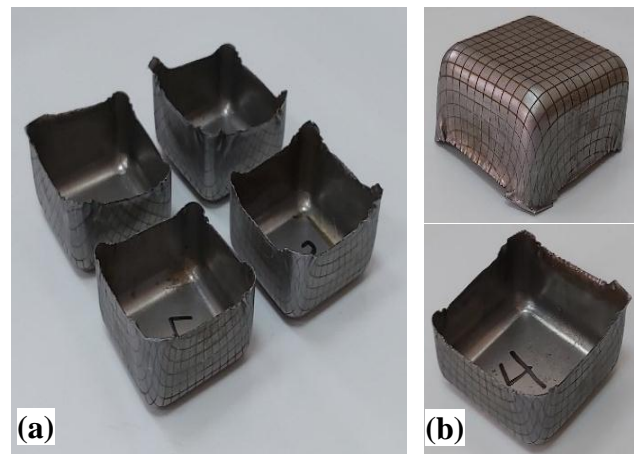

Figure 8: The produced cups; (a) the four cups drawn and (b) different views of the produced cup

## II. Strain Measurement

### 1) Direct Strain Measurement

This method of measurement involves cutting the sample before measurement and then a digital micrometer with 3-digit precision has been used for evaluating the sample thickness at 13 different points which are spaced by the size of the stretched mesh from the cup center towards its wall as shown in Figure 9. The two measuring heads of the micrometer have rounded tips thus a more accurate measurement can be attained.



Figure 9: Digital micrometer with sample

As a result, the thickness strain can be calculated according to the following relation:

$$\epsilon_t = \ln \frac{t}{t_0} \tag{1}$$

Where:  $\epsilon_t$  = thickness strain,  $t$  = measured thickness (mm),  $t_0$  = original thickness ( $t_0 = 0.5$  mm).

2) Indirect Strain Measurement

The indirect approach of strain measurement includes measuring the two side lengths of the stretched mesh after drawing along the same 13 zones specified in the direct method. Those side lengths correspond to radial and hoop directions. The measurement has been done via a digital Vernier Caliper with 2-digit precision. It is important to mention that the measurement has been repeated several times for each side to minimize or eliminate the error that may occur due to measurement problems. Radial and hoop strains should be calculated first before computing the thickness strain as follows:

$$\epsilon_r = \ln \frac{L_r}{L_0} \tag{2}$$

$$\epsilon_{\theta} = \ln \frac{L_{\theta}}{L_0} \tag{3}$$

Where:  $\epsilon_r$  &  $\epsilon_{\theta}$  are the radial and hoop strains respectively,  $L_r$  &  $L_{\theta}$  are the side lengths of the stretched mesh in radial and hoop directions respectively,  $L_0$  is the original side length before drawing which is equal to 3 mm.

Since the summation of radial, a hoop and thickness strain is zero, therefore:

$$\epsilon_t = -(\epsilon_r + \epsilon_{\theta}) \tag{4}$$

Where:  $\epsilon_t$  is the thickness strain.

6. Results and Discussion

I. Numerical Vs. Experimental Results

Both FEM and experimental results demonstrate that the square drawing of the AISI blank has been accomplished for all the four models performed as shown in Figures 5, 6 and 8 since the largest value of thickness strain was close to -0.25 indicating that the highest thinning over the cup wall does not exceed 25% of the original thickness as displayed in Figure 10 that depicts the relation between the thickness strain  $\epsilon_t$  and distance from the center for both FEM and experimental (direct and indirect) results of the four models (samples) adopted in this work. It is worth mentioning that the direct measurement values of thickness strain (indicated in green) do not match and diverge from the simulation results and tend to thicken to more than 20% of the initial thickness. Such condition is practically not acceptable due to the thinning limitation which is inherited in the deep drawing operation. This inconvenience of direct measurement may be due to fixing problems or straightness issues or both after cutting the sample causing non-flat or wavy zones leading to improper measurements. Consequently, the direct method of thickness measurement is concluded to be non-reliable and will be excluded from the subsequent sections of analysis. In general, there is a good agreement between the experimental values of the indirect method and the FEM results for all models as shown in Figure 10 such that the maximum deviation is approximately 25%.

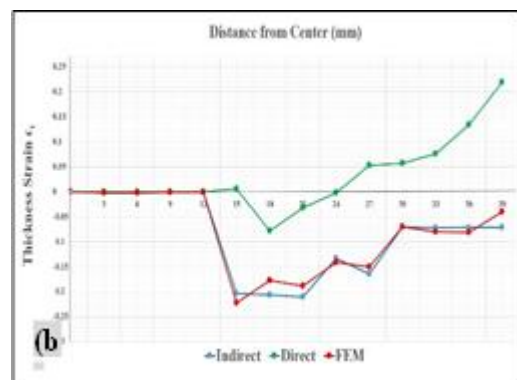
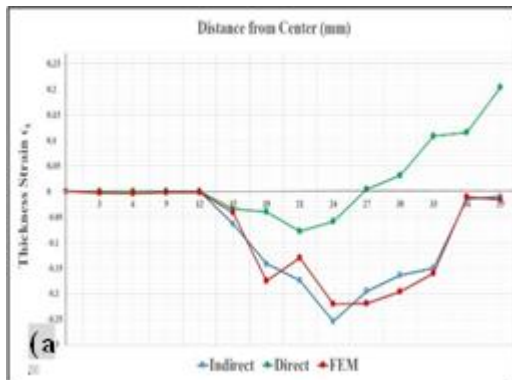



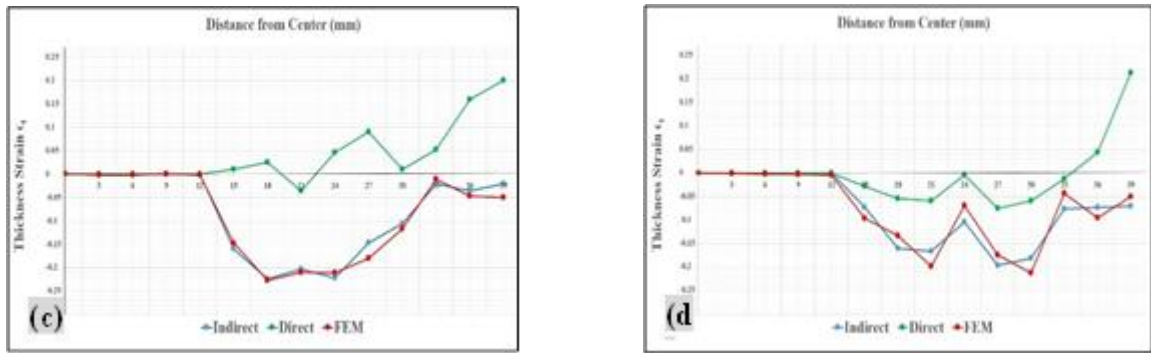

Figure 10: Thickness strains with direct, indirect and FE methods for (a) sample-1, (b) sample-2, (c) sample-3, and (d) sample-4.

II. Drawing Speed

Experimental results demonstrate generally an increase and then decrease in the absolute value of thickness strain  $\epsilon_t$  for lubricated and dry drawing at both speeds as shown in Figure 11. In general, at high speed (300 mm/min), a slight decrease of absolute  $\epsilon_t$  has been observed for both lubrication states. Such condition can be stated that at lower punch speeds, the sheet metal can be drawn more uniformly and steadily rather than forcing the metal to slide over the die cavity thus permitting larger stretching and hence higher formability of the sheet.

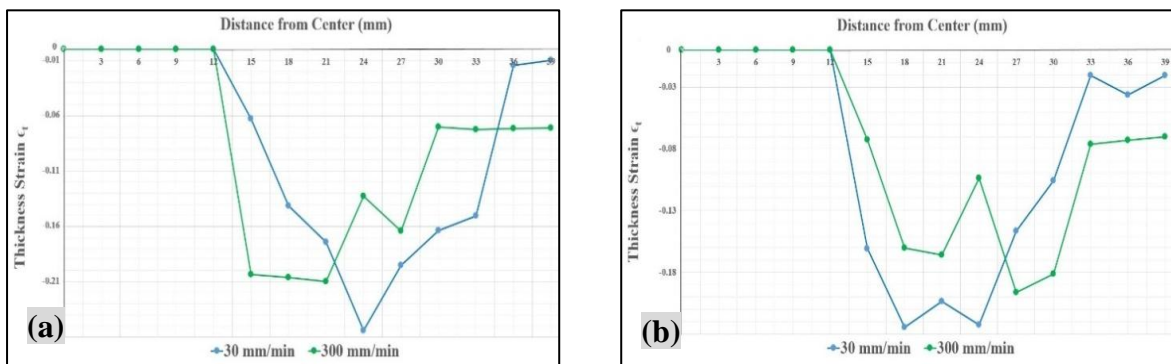

Figure 11: Thickness strain at both drawing speeds for (a) lubricated drawing and (b) dry drawing

III. Lubrication State

Experimental values of  $\epsilon_t$  prove that there is no significant difference in the formability at both speeds when using machine oil as a lubricant compared to dry drawing as depicted in Figure 12. Moreover, the distribution of thickness strain is almost similar for both states of lubrication.

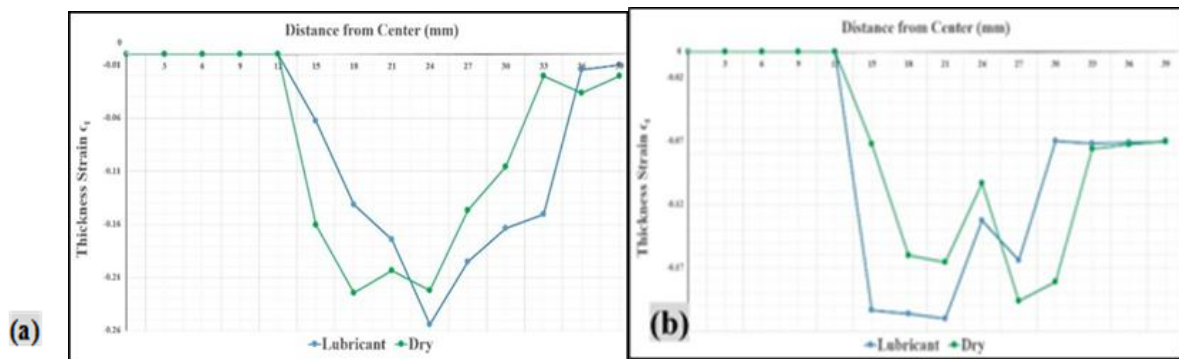

Figure 12: Thickness strain with and without lubrication for speed of (a) 30 mm/min and (b) 300 mm/min

## 7. Conclusions

The main objective of this work is to inspect the formability of drawing square cups through the deep drawing of blank type AISI 1008 having a thickness of 0.5 mm and a diameter of 80 mm. The FE and experimental investigations that have been accomplished permit to reach to the following remarks:

1. The results of both FE simulation and experimental work prove that the square drawing of the AISI sheet has been accomplished.
2. There is a good match between the experimental values of the indirect method and the FEM results for all models such that the largest deviation is about 25%.
3. The highest thinning over the cup wall does not exceed 25% of the original thickness.
4. The direct method of thickness measurement is determined to be non-confident as strain values are practically improper.
5. Higher formability of the sheet has been realized at lower punch speeds.
6. No significant difference has been observed in the formability at both punch speeds when using a lubricant compared to the dry drawing.
7. The distribution of thickness strain is almost the same for both states of lubrication.

## References

- [1] P. N. Patil and K.H. Inamdar, "A Review on deep drawing of rectangular shaped parts," Asian Journal of Convergence in Technology, Vol. II, Issue III, Issn No.:2350-1146, I.F-2.71, 2014.
- [2] K. Krachenfels, B. Rothhammer, S. Tremmel and M. Merklein, "Experimental investigation of tool-sided surface modifications for dry deep drawing processes at the tool radii area," Procedia Manufacturing, Vol. 29, pp. 201-208, 2019.
- [3] M. Mahmoodi and H. Sohrabi, "Using the Taguchi method for experimental and numerical investigations on the square-cup deep-drawing process for aluminum/steel laminated sheets," Mechanics of Advanced Composite Structures, Vol. 4, pp. 169-177, 2017.
- [4] M. Hassan, L. Hezam, M. El-Sebaie and J. Purbolaksono, "Deep drawing characteristics of square cups through conical dies," Procedia Engineering, Vol. 81, pp. 873 – 880, 2014.
- [5] Y. Harada and M. Ueyama, "Formability of pure titanium sheet in square cup deep drawing," Procedia Engineering, Vol. 81, pp. 881 – 886, 2014.
- [6] W. M. Shewakh, M. A. Hassan and I. M. Hassab-Allah, "Square-cup deep drawing of relatively thick sheet metals through a conical die without blank holder," International Journal of Materials Forming and Machining Processes, Vol. 2, No.2, pp. 31-46, 2015.
- [7] J. Tenner, K. Andreas, A. Radius and M. Merklein, "Numerical and experimental investigation of dry deep drawing of aluminum alloys with conventional and coated tool surfaces," Procedia Engineering, Vol. 207, pp. 2245-2250, 2017.
- [8] K. Muhsin Younis, A. S. Jabber and M. M. Abdulrazaq, "Experimental evaluation and finite element simulation to produce square cup by deep drawing process", Al-Khwarizmi Engineering Journal, Vol. 14, No. 1, pp. 39-51, 2018.
- [9] G. Reichardt and M. Liewald, "Investigation on friction behavior of deep drawing radii using volatile media as lubricant substitutes," Procedia Manufacturing, Vol. 29, pp. 193-200, 2019.

- [10] S. Suttner, H. Schmid and M. Merklien, "Cross-profile deep drawing of magnesium alloy az31 sheet metal for springback analysis under various temperatures," *Procedia Manufacturing*, Vol. 29, pp. 406-411, 2019.
- [11] K. M. Younis and A. S. Jaber, "Experimental and numerical study of the earing defect during square deep drawing process," *Engineering and Technology Journal*, Vol. 36, Part A, No. 12, pp. 1267-1275, 2018.