



Optimal Localization of UPFC For Transmission Line Losses Minimizing Using Particle Swarm Optimization

Ihssan A. Amin^{a*}, Dhari Y. Mahmood^b, Ali H. Numan^c

^{a,b}Electrical Engineering Dept., University of Technology-Iraq, Alsina'a street,10066 Baghdad, Iraq.

^cElectromechanical Engineering Dept., University of Technology-Iraq, Alsina'a street,10066 Baghdad, Iraq.

*Corresponding author Email: 31622@student.uotechnology.edu.iq

HIGHLIGHTS

- Determine the best location of the unified power flow controller (UPFC) for utilizing in 400KV Iraqi national grid (ING).
- Novel comparative analysis between classical proportional integral (PI) controller and an optimal controller such as particle swarm optimization (PSO).
- Propose an effective method for transmission line active and reactive losses minimization.
- Investigate the load flow analysis of the power system using Newton Raphson's method.

ABSTRACT

Losses in the transmission line have a significant and growing impact on power systems around the world. Line losses overheat power lines, therefore electrical power systems require powerful processors and intelligent management methods. Flexible AC Transmission System (FACTS) device UPFC is one of the most important devices due to its ability to reduce total line losses that cause an increase in the transmission line capacity of the power system. In this paper, we used Particle Swarm Optimization (PSO) to determine the optimal location for the installation of UPFC device to minimize losses in the transmission line in the Iraqi international grid (ING) 400kV using a proportional-integral (PI) based UPFC controller. The potential solutions of PSO are called particles. All the particles selected in this controller depend on their parameter only, which keeps feasible solutions in their memory. The algorithm is coded in MATLAB and it is incorporated with the conventional Newton Raphson's load flow analysis. The result shows that the proposed optimization method applied for two UPFC compensator parameters in the power system contributed to minimizing the active and reactive power losses under normal operating conditions using a modified version of the PSO algorithm.

ARTICLE INFO

Handling editor: Ivan A. Hashim

Keywords:

FACT device

UPFC

PSO

PI controller

MATLAB programs/M-file

1. Introduction

Today's power systems are very broad and interconnected [1], and one of the most sophisticated man-made structures can be said to be power systems. Energy transmission lines are one of the components of the system responsible for the transmission of energy from production centers to load centers. These lines must have maximum reliability for power transmission. With the increase in electricity demand and the need for more power transmission, new transmission lines will have to be built or existing lines be equipped. The first one seems to be impractical due to problems with the power system. However, the latter is applicable and has fewer problems. The equipment is equipped with modern reactive power compensation equipment FACTS. By changing the network parameters, FACTS devices can directly control the throughput of lines. The FACTS is remarkably and rapidly integrated with power transmission lines. It can provide the necessary boost to power transmission lines, especially the UPFC type, which consists of two self-connected converters connected with two transformers, one is connected in parallel with the transmission line, while the other one is connected in series [2][3].

<http://doi.org/10.30684/etj.v39i10.1656>

Received 25 March 2020; Accepted 30 May 2020; Available online 25 October 2021

2412-0758/©Publishing rights belongs to University of Technology's Press, Baghdad, Iraq

This is an open access article under the CC BY 4.0 license (<http://creativecommons.org/licenses/by/4.0>).

The problem of the paper lies in finding the optimal location and optimal values of the UPFC device on the ING (400kV) and thus improving the overall performance of the network. Therefore, this paper deals with the applications of PSO to find the optimal placement and setting parameter of the UPFC device.

The authors in [4] presented the real-time implementation of an FLC based UPFC to control the transmission line power flow. The proposed controller is validated on IEEE 14 bus network. The performance of the proposed controller is tested under different references, and load variations. Furthermore, the response of the proposed FLC based UPFC was compared to PI-based UPFC. The results showed that the proposed FLC based UPFC has enhanced power flowability, improved bus voltages, and reduced the power losses of the networks more than the PI-based UPFC. FLC based UPFC enhanced active power flow by 5.86 % and reduced power losses. The authors in [5] used the UPFC as a strong candidate to provide full dynamic control of power transmission line operating parameters: voltages, line impedance, and phase angle under normal and fault conditions. Simulink model consists of 4-bus system equipped with UPFC to illustrate the control features of this device and their influence to improve system stability. The effect of static synchronous compensator (STATCOM), static synchronous compensator series (SSSC), and UPFC on real power, reactive power, and the voltage presented UPFC into the transmission system and the obtained better results showed that the UPFC improved the voltage profile as well as controlled the aggressive and reactive strength of the buses and lines without losing control even during the fault conditions. The authors in [6] used FACTS device, specifically UPFC, and used GA to determine the optimal location and the parameter of UPFC to improve the voltage profile, minimize power losses, treat power flow in overloaded transmission lines, and reduce power generation. GA was applied to find the optimal values and locations of UPFC to an Iraqi international power grid system (Diyala 132 kV). The obtained result showed the effectiveness of GA to calculate the optimum values and locations of UPFC, and promising results were obtained for the Diyala power network (132 kV) about the desired objectives. The authors in [7] proposed a relationship to identify the numbers of FACTS devices that can be used to install for a given power network, and the process of GA was used to determine the optimal placement, optimal number, and size of UPFC device to reduce overall system losses and enhance the voltage profile in the IEEE 14 bus test system. The obtained results showed that all control parameters of UPFCs in each case are within their limits, and whenever the number of UPFCs installed increases, voltages deviates, and total losses will be decreased. They also showed that the application of the proposed relationship, in-process GA codes, greatly facilitated the search for the optimal number, optimal placement, and the size of UPFC devices and minimized the calculation time too.

2. Losses in Transmission Line

Minimizing losses has an important role in studies on the power system. Variable compensation can reduce transmission line losses in a power system. The importance and use of FACTS systems for manipulating line power flows to relieve congestion and maximize general grid operation has been improved following the establishment of power markets with open transmission access [8].

These losses in transmission power have been caused by multiple physical and working variables such as (line resistance, inductance, capacitance, bundled conductors, low-efficiency materials, line length, and voltages). Minimizing or controlling some of these variables will enhance the power flow, line losses, and decrease the cost of the device.

3. FACT device

Since the 1960s, discussions of dynamic stability have received much attention. In certain power systems, two or more methods may need to be used simultaneously, but in any case, the proposed method must also be economically justified. High voltage transmission lines have an important role in improving dynamic and transient stability due to their controllability. With the advent of electrical technology and the development of high-voltage and high voltage equipment, direct current transmission lines and alternating current flexible elements (FACTS) have been justified economically. FACTS devices have the capability of controlling the active and reactive power transmission components in lines, so they control when these components can achieve both transient and dynamic stability modifications [9].

4. Unified Power Flow Controller (UPFC)

The UPFC is a member of the second-generation FACTS family devices and it was proposed by Gyugi in 1992 [10]. It is a generalized AC transmission controller that has multiple functional capabilities and thus, it is capable of performing (simultaneously or selectively) the compensation and control functions of different individual line compensators and controllers", and there are many different ways to introduce and explain the concept of the UPFC. It requires an approach of mathematics, vector or phasor diagrams, or various plots to show graphical relationships among the main transmission parameters, active and reactive power, voltage, line impedance, and transmission angle [11][12]. The UPFC conducts power flow management in transmission lines by changing line parameters, including bus voltages, phase angle and line impedance, which include all other FACTs adjustable parameters [13]. Figure 1 shows the UPFC structure.

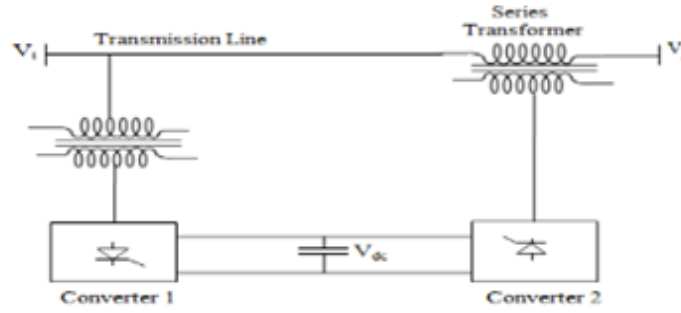

Figure 1: The UPFC structure [3]

5. Power Flow Model of the UPFC

From the circuit shown in Figure 2.a, the two ideal voltage source converters of UPFC can be represented mathematically as:[14]

$$E_{vR} = V_{vR}(\cos\delta_{vR} + j \sin \delta_{vR}) \tag{1}$$

Where V_{vR} Controllable source ($V_{vR\min} \leq V_{vR} \leq V_{vR\max}$) of voltage magnitude serving shunt converter.

δ_{vR} phase angle ($0 \leq \delta_{vR} \leq 2\pi$) of the voltage magnitude serving shunt converter.

V_{cR} controllable source ($V_{cR\min} \leq V_{cR} \leq V_{cR\max}$) of voltage magnitude serving the series converter.

δ_{cR} phase angle ($0 \leq \delta_{cR} \leq 2\pi$) of the voltage source representing the series converter [15].

The active(P) and reactive(Q) power equations are based on the equivalent circuit seen in Figure 2 and Equations (1), (2) as follows[2] [16]:

At bus k:

$$P_k = V_k^2 G_{kk} + V_k V_n [G_{kn} \cos(\theta_k - \theta_n) + B_{kn} \sin(\theta_k - \theta_n)] + V_k V_{cR} [G_{kn} \cos(\theta_k - \delta_{cR}) + B_{kn} \sin(\theta_k - \delta_{cR})] + V_k V_{vR} [G_{vR} \cos(\theta_k - \delta_{vR}) + B_{vR} \sin(\theta_k - \delta_{vR})] \tag{3}$$

$$Q_k = -V_k^2 B_{kk} + V_k V_n [G_{kn} \sin(\theta_k - \theta_n) - B_{kn} \cos(\theta_k - \theta_n)] + V_k V_{cR} [G_{kn} \sin(\theta_k - \delta_{cR}) - B_{kn} \cos(\theta_k - \delta_{cR})] + V_k V_{vR} [G_{vR} \sin(\theta_k - \delta_{vR}) + B_{vR} \cos(\theta_k - \delta_{vR})] \tag{4}$$

At bus n:

$$P_n = V_n^2 G_{nn} + V_n V_k [G_{nk} \cos(\theta_n - \theta_k) + B_{nk} \sin(\theta_n - \theta_k)] + V_n V_{cR} [G_{nn} \cos(\theta_n - \delta_{cR}) + B_{nn} \sin(\theta_n - \delta_{cR})] \tag{5}$$

$$Q_n = -V_n^2 B_{nn} + V_n V_k [G_{nk} \sin(\theta_n - \theta_k) - B_{nk} \cos(\theta_n - \theta_k)] + V_n V_{cR} [G_{nn} \sin(\theta_n - \delta_{cR}) - B_{nn} \cos(\theta_n - \delta_{cR})] \tag{6}$$

• **Series converter:**

$$P_{cR} = V_{cR}^2 G_{nn} + V_{cR} V_k [G_{kn} \cos(\delta_{cR} - \theta_k) + B_{kn} \sin(\delta_{cR} - \theta_k)] + V_{cR} V_n [G_{nn} \cos(\delta_{cR} - \theta_n) + B_{nn} \sin(\delta_{cR} - \theta_n)] \tag{7}$$

$$Q_{cR} = -V_{cR}^2 B_{nn} + V_{cR} V_k [G_{kn} \sin(\delta_{cR} - \theta_k) - B_{kn} \cos(\delta_{cR} - \theta_k)] + V_{cR} V_n [G_{nn} \sin(\delta_{cR} - \theta_n) - B_{nn} \cos(\delta_{cR} - \theta_n)] \tag{8}$$

• **Shunt converter**

$$P_{vR} = V_{vR} V_k [G_{vR} \cos(\delta_{vR} - \theta_k) + B_{vR} \sin(\delta_{vR} - \theta_k)] - V_{vR}^2 G_{vR} \tag{9}$$

$$Q_{vR} = V_{vR} V_k [G_{vR} \sin(\delta_{vR} - \theta_k) - B_{vR} \cos(\delta_{vR} - \theta_k)] + V_{vR}^2 B_{vR} \tag{10}$$

Where P_k, P_n active power at bus k and bus n respectively.

Q_k, Q_n reactive power at bus k and bus n respectively.

P_{cR}, P_{vR} active power of series and shunt converter respectively.

Q_{cR}, Q_{vR} reactive power of series and shunt converter respectively

V_k, V_n voltage magnitudes at bus k and bus n respectively.

θ_k, θ_n power angles at bus k and bus n respectively.

G_{nk}, G_{kn} the conductance of the line between bus k and bus n

B_{nn}, B_{kk} substances at bus k and bus n respectively

B_{nk}, B_{kn} the conductance of the line between bus k and bus n respectively.

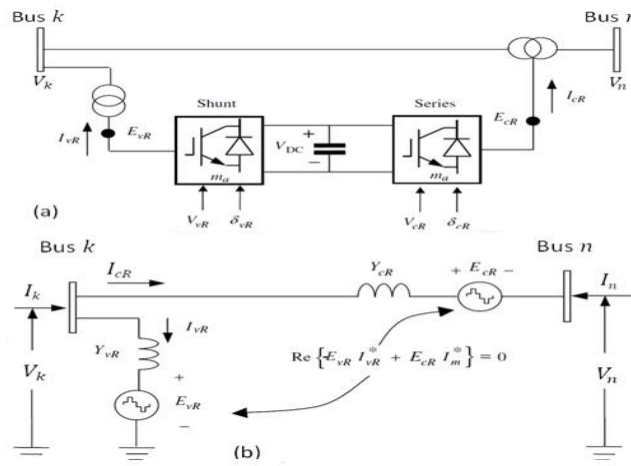

Figure 2: UPFC system: (a) UPFC Configuration, (b) UPFC equivalent circuit

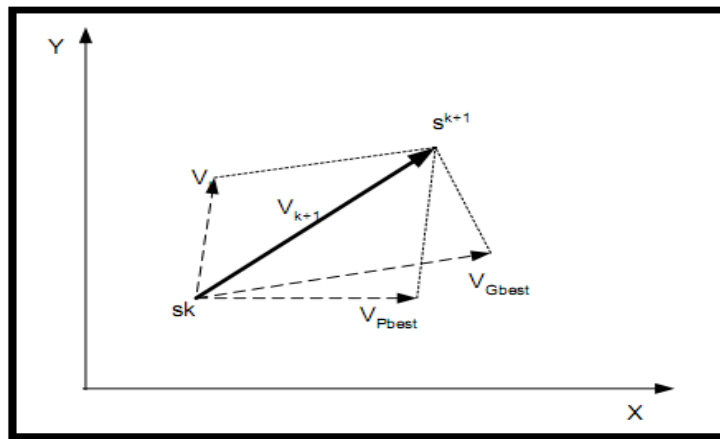

Figure 3: The search-point principle in PSO

The converters of UPFC are assumed lossless converter values in the voltage sources model, and this shows that both converters will not be involved in generation (or absorbing) power for its losses, and the demand of active (P) power by the series converter at its output is supplied from the ($A.C$) power system by the shunt converters via the common ($D.C$) link. The voltage of the capacitor V_{dc} of a ($D.C$) link will remain constant. Thus, the active power supplied to the shunt converter, P_{vR} equals the active power demanded by the series converters, P_{eR} . Then it is important to guarantee the following restriction on equality [2].

$$\Delta P_{db} = P_{vR} + P_{eR} = 0 \tag{11}$$

Moreover, if the connecting transformers are supposed to hold no resistance, then the active power on bus_k equals the active powers on bus_n . so,

$$P_{vR} + P_{eR} = P_k + P_n = 0 \tag{12}$$

The UPFC power equations, in linearized form, are combined with those of the ($A.C$) network.

For the situation where UPFC dominates the following parameters:

- 1) Voltages magnitude at the shunt converters terminal bus k .
- 2) Active (P) power flow from (bus_n) to (bus_k).
- 3) Reactive power (Q) injected at (bus_n), and taken (bus_n) to be a (PQ bus).

The linearization of the equations is as follows [2]:

$$\begin{bmatrix} \Delta P_k \\ \Delta P_n \\ \Delta Q_k \\ \Delta Q_n \\ \Delta P_{nk} \\ \Delta Q_{nk} \\ \Delta P_{bb} \end{bmatrix} = \begin{bmatrix} \frac{\partial P_k}{\partial \theta_k} & \frac{\partial P_k}{\partial \theta_n} & \frac{\partial P_k}{\partial V_{vR}} V_{vR} & \frac{\partial P_k}{\partial V_n} V_n & \frac{\partial P_k}{\partial \delta_{cR}} & \frac{\partial P_k}{\partial V_{cR}} V_{cR} & \frac{\partial P_k}{\partial \delta_{vR}} \\ \frac{\partial P_n}{\partial \theta_k} & \frac{\partial P_n}{\partial \theta_n} & 0 & \frac{\partial P_n}{\partial V_n} V_n & \frac{\partial P_n}{\partial \delta_{cR}} & \frac{\partial P_n}{\partial V_{cR}} V_{cR} & 0 \\ \frac{\partial Q_k}{\partial \theta_k} & \frac{\partial Q_k}{\partial \theta_n} & \frac{\partial Q_k}{\partial V_{vR}} V_{vR} & \frac{\partial Q_k}{\partial V_n} V_n & \frac{\partial Q_k}{\partial \delta_{cR}} & \frac{\partial Q_k}{\partial V_{cR}} V_{cR} & \frac{\partial Q_k}{\partial \delta_{vR}} \\ \frac{\partial Q_n}{\partial \theta_k} & \frac{\partial Q_n}{\partial \theta_n} & 0 & \frac{\partial Q_n}{\partial V_n} V_n & \frac{\partial Q_n}{\partial \delta_{cR}} & \frac{\partial Q_n}{\partial V_{cR}} V_{cR} & 0 \\ \frac{\partial P_{nk}}{\partial \theta_k} & \frac{\partial P_{nk}}{\partial \theta_n} & 0 & \frac{\partial P_{nk}}{\partial V_n} V_n & \frac{\partial P_{nk}}{\partial \delta_{cR}} & \frac{\partial P_{nk}}{\partial V_{cR}} V_{cR} & 0 \\ \frac{\partial Q_{nk}}{\partial \theta_k} & \frac{\partial Q_{nk}}{\partial \theta_n} & 0 & \frac{\partial Q_{nk}}{\partial V_n} V_n & \frac{\partial Q_{nk}}{\partial \delta_{cR}} & \frac{\partial Q_{nk}}{\partial V_{cR}} V_{cR} & 0 \\ \frac{\partial P_{bb}}{\partial \theta_k} & \frac{\partial P_{bb}}{\partial \theta_n} & \frac{\partial P_{bb}}{\partial V_{vR}} V_{vR} & \frac{\partial P_{bb}}{\partial V_n} V_n & \frac{\partial P_{bb}}{\partial \delta_{cR}} & \frac{\partial P_{bb}}{\partial V_{cR}} V_{cR} & \frac{\partial P_{bb}}{\partial \delta_{vR}} \end{bmatrix} \begin{bmatrix} \Delta \theta_k \\ \Delta \theta_n \\ \Delta V_{vR} \\ V_{vR} \\ \Delta V_n \\ V_n \\ \Delta \delta_{cR} \\ \Delta V_{cR} \\ V_{cR} \\ \Delta \delta_{vR} \end{bmatrix} \tag{13}$$

6. Proportional Integral Controller (PI)

The selection method of the PI controller parameters, (proportional and integral gains), of the series and shunt converter, should be chosen in a way that allows the process under regulation to be more stable. Control loop tuning updates the system parameters to the necessary system output for optimum values. The parameters of the PI controller’s gains (Kp and Ki) are given in Table 1.

Table 1: PI controller gains of series and shunt controllers of UPFC

Serie Converter		Shunt Converter	
Kp	Ki	Kp	Ki
0.025		0.01867	
0.15813		0.2023	

7. Particle Swarm Optimization (PSO)

In 1995, a PSO algorithm was proposed by Kennedy and Eberhart. This algorithm is located in the congestion intelligence branch. That is, the principle of this algorithm is to share information and experiences. Figure 3 shows the search-point principle in PSO [17]. PSO was created by simulating simplistic versions of society. The system functions as follows:

- 1) Research into swarms such as fish schooling and a flock of birds is based on the process.
- 2) It is based on simple concepts. Therefore, it requires a few memories and the computation time is short.
- 3) It was originally developed with continuous variables for nonlinear optimization problems.

This modification may be expressed by the velocity equation, and the velocity of each agent can be changed by the following equation [18]:

$$\begin{aligned} V_{id}^{kO+1} &= wV_{id}^{kO} + C_1 \times rand(Pbest_{id} - X_{id}^{kO}) + C_2 \times rand(Gbest_{id} - X_{id}^{kO}) \tag{14} \\ X_{id}^{kO+1} &= X_{id}^{kO} + V_{id}^{kO+1} \quad i = 1, 2, 3, \dots, n \tag{15} \end{aligned}$$

d = 1, 2, ..., m

Where X_{id}^{kO} and X_{id}^{kO+1} are current and modified searching point respectively,

V_{id}^{kO} and V_{id}^{kO+1} are current and modified velocity respectively,

V_{pbest} and V_{gbest} are velocity based on p_{best} g_{best} respectively,

n is the number of the particles in a group

m are members in a particle

$Pbest$ is the best position of the ith particle

$Gbest$ is the best particle among all the particles in the group

w_i is the weight function velocity of the agent i ,

c_i is the weight factors for each term.

The following function is used for the weight:

$$w_{(i)} = w_{max} - \left(\frac{w_{max} - w_{min}}{kO_{max}} \right) * k_0 \tag{16}$$

Where w_{min} and w_{max} are the minimum and maximum weights, respectively.

kO_{max} , k_0 are the maximum and current iterations, respectively.

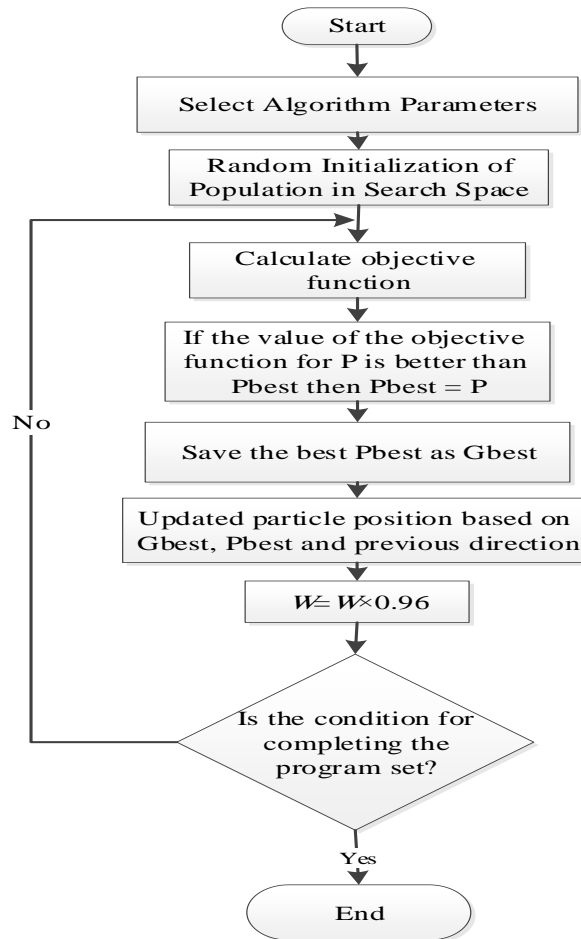

Figure 4: Flowchart of the modified particle swarm optimization algorithm

In general, the steps of the particle swarm algorithm are as follows, and Figure 4 shows the flowchart for this step.

- 1) Random production of the initial population and its evaluation.
- 2) Choosing the best personal memories and the best collective memories.
- 3) Updating the speed and location and evaluating new responses.
- 4) Multiply the coefficient w by the attenuation rate of 0.96.
- 5) If the algorithm's stopping conditions are not met, the second step is to return.

The steps to perform optimization by the PSO algorithm (Figure 5) for the optimal location of the UPFC and minimizing the losses in the transmission line are as follows:

Step 1: Modeling the Iraqi power system in MATLAB (transmission lines, generators, loads parameters of the Iraqi power system are coded in MATLAB with matrixes).

Step 2: Adjust the parameters of the PSO algorithm (Population, Maxite, C1, C2, Vmin, Vmax, and ω).

Step 3: The particles are randomly quantified (each particle determines places of UPFCs installation).

Step 4: If there is no transmission line between two chosen buses, consider the loss equals to a large number (Loss=1e10) and jump to step six.

Step 5: Perform load flow and calculate the loss for each particle (Objective function=Loss).

Step 6: Calculate the velocity (V) for each particle, and update the particle position (new location for UPFC installation).

Step7: If the number of iterations is less than Maxite jump to Step 4. Otherwise, go to Step 8.

Step 8: End of simulation.

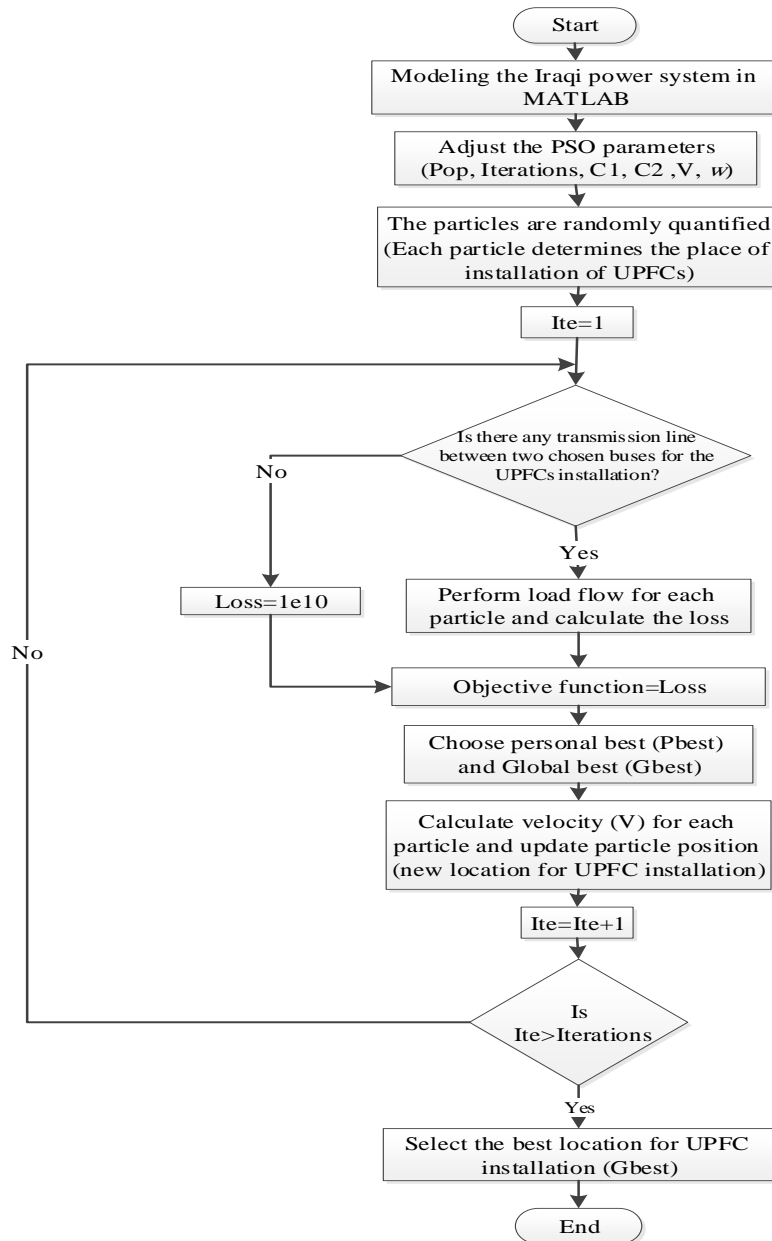

Figure 5: Flowchart of the modified PSO for UPFC placement

8. Results and Discussion

The optimal design of FACTS device systems plays an important role in achieving the optimal functioning of these applications. In this paper, we can use the PSO to determine the optimal location and the UPFC to minimize the Active (P) and Reactive (Q) power losses in the transmission line. The optimal location for two UPFC devices by using (PI) controller-based for the (ING) system was between buses (18-8) and (19-21) respectively. These locations contributed to minimizing the active and reactive power losses under normal operating conditions.

Optimal determination of the UPFC compensators with the PI controller and finding the best places to install the UPFCs to reduce active power loss are done by the modified particle swarm algorithm. The parameters of the optimization algorithm are presented and optimization results for UPFCs with the PI controller are given in Tables 1 and 2, respectively.

9. The Iraqi Electrical Network

The main goal of this work is to minimize the power system losses in the transmission line using the optimum location of the UPFC device. The transmission level of the Iraqi electrical power grid is based on 400 kV and the 132kV. In this paper, 400kV networks with their buses and transmission line will be investigated. The proposed method for loss minimization has been applied to the Iraqi national grid. This grid has twenty-nine buses and forty-seven transmission lines. The single line diagram for this test system is shown in Figure 6.

9.1 Fixed Load Condition (Without UPFC)

The ING power system's active and reactive power losses without any compensations are 89.22 MW and 791.8 MVar, respectively. The branch losses are shown in Figures 7 and 8.

Table 2: The PSO algorithm's parameters

Population	Iteration	C1=C2	W	Vmin	Vmax	D
100	35	2	0.7	0.4	0.9	0.95

Table 3: The optimization results for UPFCs with the PI controller

	UPFC I		UPFC II		Serie Converter		Shunt Converter	
	L1	L2	L3	L4	Kp	Ki	Kp	Ki
PSO	18	8	19	21	0.025	0.15813	0.1867	0.2023

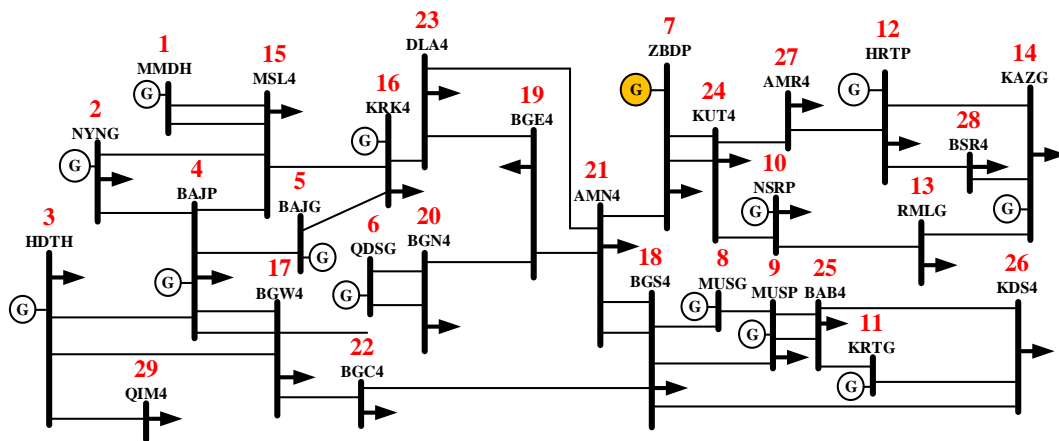

Figure 6: Single line diagram of the INSG

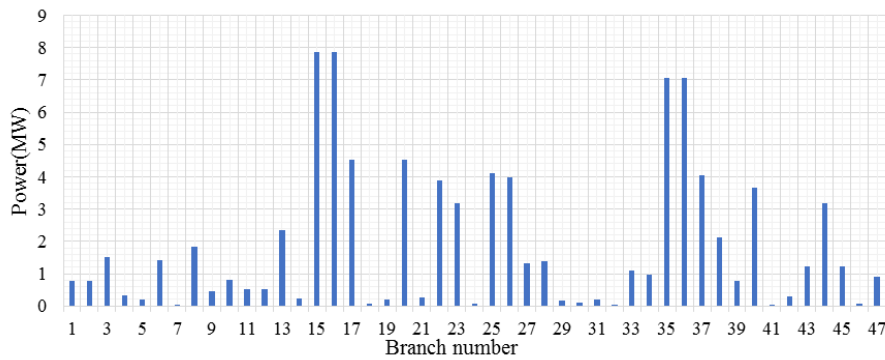

Figure 7: Active power losses without UPFC

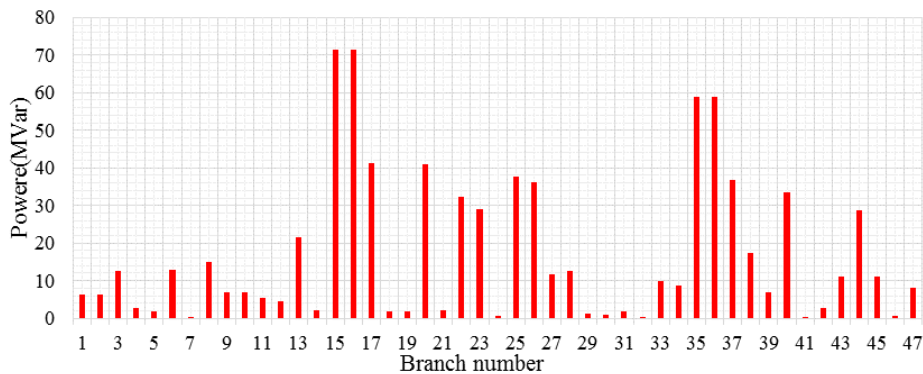

Figure 8: Reactive power losses without UPFC

9.2 With UPFC Based on PI for optimal Location

For this part of the simulation on the ING power system, two UPFCs with PI controllers are used for power loss reduction. The PSO algorithm was proposed to install the UPFCs on buses number (18-8), (BGS4-MUSG), and (BGE4-AMN4), (19-21). Under these circumstances, the system's active losses decreased by 31.36% to 61.2405 MW and the reactive losses decreased to 549.6089 MVar, which was reduced to 30.58% compared to pre-compensation conditions. The results are shown in Figures 9 -10.

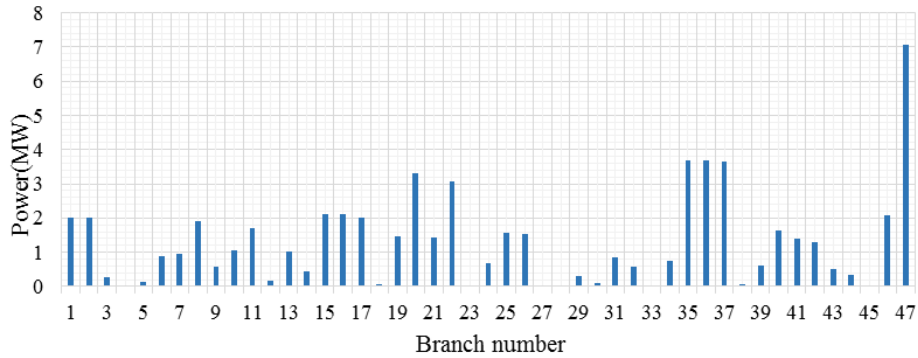

Figure 9: Active Power Losses (MW) with UPFC using PI

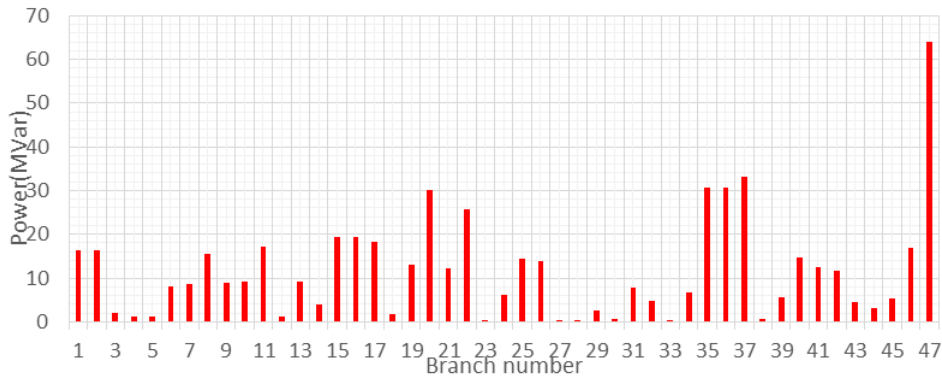

Figure 10: Reactive Power Losses (MVar) with UPFC using PI

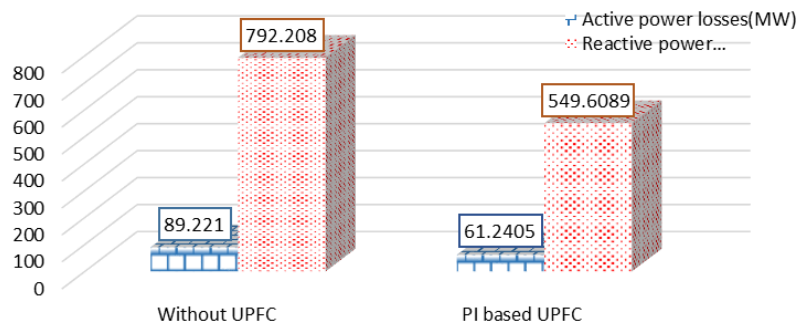

Figure 11: Total Active and Reactive power losses without and with PI

Table 4: Total Active and Reactive Power Losses with UPFC(PSO)

Case of Normal operation condition	Active power losses (P)	Reactive power losses (Q)
Without UPFC	89.220 (MW)	791.8260 (MVar)
PI-based UPFC	61.2405 (MW)	549.6030 (MVar)
Improvement%	31.36%	30.58%

The active (P) and reactive (Q) power losses using PI under fixed load conditions at the optimal location of the UPFC are presented in Table 4. The obtained results proved that the PI method reduces the active and reactive power losses.

10. Conclusions

In this paper, the optimal placement of UPFC compensators with the PI controller for the Iraqi National Grid (ING) is done. For this purpose, a modified version of the PSO algorithm is used. The algorithms are used for choosing the optimal parameters of the controllers and finding the best place for UPFCs installation. Optimization aims to reduce active and reactive

losses in the power systems. The performance of UPFCs with PI controllers to reduce the Iraqi National Grid (ING) losses were analyzed. The active and reactive losses of the ING power system after using the UPFCs at the proposed places chosen by the PSO algorithm were 61.2405 (MW) and 549.6030(MVar), respectively. The active and reactive loss reductions were about 31.36% and 30.58%, respectively.

Author contribution

All authors contributed equally to this work.

Funding

This research received no specific grant from any funding agency in the public, commercial, or not-for-profit sectors.

Data availability statement

The data that support the findings of this study are available on request from the corresponding author.

Conflicts of interest

The authors declare that there is no conflict of interest.

References

- [1] J. Sahlin, Line Loss Prediction Model Design at Svenska kraftnät, (2016).
- [2] E. Acha, et al. FACTS Modeling and Simulation in Power Networks, John Wiley and Sons LTD, England, (2004).
- [3] N. G. Hingorani and L. Gyugyi, Understanding FACTS Concepts and Technology of Flexible AC Transmission Systems, IEEE Press, New York, (2000).
- [4] F. M. Albatsh, S. Ahmad, S. Mekhilef, I. Alhamrouni, and M. F. A. Hamid, Power flow control using fuzzy based UPFC under different operating conditions, Journal Electrical of Systems, 13, 2, (2017), 398–414.
- [5] A. Touhami, Enhancement of Active and Reactive Power Flow Control over the Transmission Line using UPFC, International Journal of Computer Science, communication & information Technology, 6, (2018), 1–8.
- [6] G. A. Salman, M. H. Ali, and A. N. Abdullah, Implementation Optimal Location and Sizing of UPFC on Iraqi Power System Grid (132 kV) Using Genetic Algorithm, International Journal of Power Electronics and Drive Systems, 9, 5, (2018), 1607-1615.
- [7] S. Hocine and L. Djamel, Optimal number and location of UPFC devices to enhance voltage profile and minimizing losses in electrical power systems, International Journal of Electrical and Computer Engineering (IJECE), 9, 5, (2019), 3981–3992.
- [8] K. K. Kuthadi, M. S. Babu, and N. Tella, Optimal Location and Parameter Settings of FACTS Devices for Enhancing Power System Stability and Minimization of Power Losses, Inte. Jou. of Engineering Science and Technology (IJEST), 4, 06, (2012), 2699–2707.
- [9] S. V Patil and P. K. Mahajan, A Review on Implementation of UPFC for improvement of active power flow capability in power system using IEEE 14 bus system International Research Journal of Engineering and Technology (IRJET), 4, 4, (2017), 542–547.
- [10] L. Gyugyi, Unified power-flow control concept for flexible AC transmission systems, IEE Proceedings C Generation, Transmission and Distribution, 139, 4, (1992).
- [11] Laszlo Gyugyi, Advanced Solutions in Power Systems: HVDC, FACTS, and Artificial Intelligence, Chapter 10, (2016).
- [12] R. Sadikovic, Power flow control with UPFC, 1–20, (2015).
- [13] L. P. YIN Jijun, CHEN Gang, XU Haiqing, LI Qun, LIU Jiankun, Unified Power Flow Controller Technology and Application, Academic Press, (2017).
- [14] C. R. Fuerte-Esquivel, E. Acha, and H. Ambriz-Pérez, A comprehensive newton-raphson UPFC model for the quadratic power flow solution of practical power networks, IEEE Transactions on Power Systems, 15, 1, (2000), 102–109.
- [15] A. Moamen, M. Abdel, R. Ahmed, Optimal Power Flow with Facts Devices, PhD Thesis, Department of Electrical Engineering Indian Institute of Technology, Roorkee, (2004).
- [16] M. Zahid et al., New approach for optimal location and parameter setting of upfc for enhancing power systems stability under contingency analysis, Energies, 10, 11, (2017).
- [17] Y. Shi and R. Eberhart, A Modified particle swarm optimizer, Proceedings of the IEEE Conference on Evolutionary Computation, ICEC, 1998, 69–73.
- [18] M. Clerc, Particle Swarm Optimization. ISTE Ltd, USA, (2006).

